



EVALKITST7580-1

ST7580 power line networking system-on-chip demonstration kit

Data brief

Features

- Suitable for point-to-multipoint 2-way power line communication (PLC) over AC mains
- Flexible 2-board architecture:
 - EVALST7580-1, PLC board based on the ST7580 narrow-band FSK/PSK power line networking system-on-chip
 - EVLALTAIR900-M1, wide-range input voltage, 7.5 W power supply board based on the ALTAIR04-900 quasi-resonant current-mode SMPS controller
- STM32 microcontroller hosted on the EVALST7580-1 board to handle the ST7580 device and build a standalone power line node
- External access through several interface types: USB, SPI, I²C, USART, JTAG
- Opportunity to save and load data to/from an external μ -SD card
- Intuitive graphical user interface (GUI) for the Windows[®] environment with fully programmable transceiver parameters
- Suitable for CENELEC EN50065 and FCC part 15 compliant applications



EVALKITST7580-1

Description

Built around the ST7580 power line networking system-on-chip, this demonstration kit embeds all the functions required for a “turnkey” power line communication network: the PLC node based on the ST7580, the AC power supply (based on the ALTAIR4-900 chip) and the STM32 microcontroller, to either control the system as a standalone application or to connect the EVALKITST7580-1 to an external host.

The typical application environment consists of two or more EVALKITST7580-1s connected to the same mains line, each being controlled by a PC running the ST7580 GUI software.

1 Block diagram

Figure 1. EVALKITST7580-1 functional block diagram

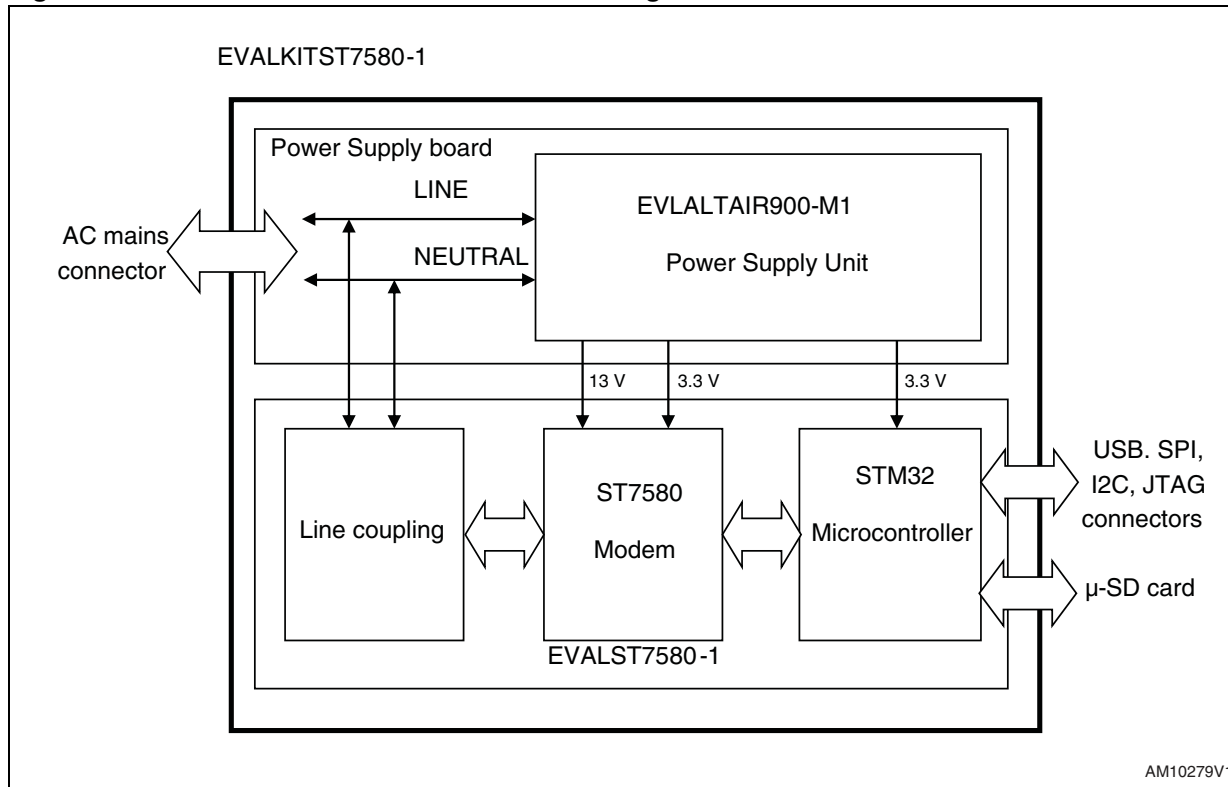

2 Revision history

Table 1. Document revision history

Date	Revision	Changes
15-Feb-2012	1	Initial release.

Please Read Carefully:

Information in this document is provided solely in connection with ST products. STMicroelectronics NV and its subsidiaries ("ST") reserve the right to make changes, corrections, modifications or improvements, to this document, and the products and services described herein at any time, without notice.

All ST products are sold pursuant to ST's terms and conditions of sale.

Purchasers are solely responsible for the choice, selection and use of the ST products and services described herein, and ST assumes no liability whatsoever relating to the choice, selection or use of the ST products and services described herein.

No license, express or implied, by estoppel or otherwise, to any intellectual property rights is granted under this document. If any part of this document refers to any third party products or services it shall not be deemed a license grant by ST for the use of such third party products or services, or any intellectual property contained therein or considered as a warranty covering the use in any manner whatsoever of such third party products or services or any intellectual property contained therein.

UNLESS OTHERWISE SET FORTH IN ST'S TERMS AND CONDITIONS OF SALE ST DISCLAIMS ANY EXPRESS OR IMPLIED WARRANTY WITH RESPECT TO THE USE AND/OR SALE OF ST PRODUCTS INCLUDING WITHOUT LIMITATION IMPLIED WARRANTIES OF MERCHANTABILITY, FITNESS FOR A PARTICULAR PURPOSE (AND THEIR EQUIVALENTS UNDER THE LAWS OF ANY JURISDICTION), OR INFRINGEMENT OF ANY PATENT, COPYRIGHT OR OTHER INTELLECTUAL PROPERTY RIGHT.

UNLESS EXPRESSLY APPROVED IN WRITING BY TWO AUTHORIZED ST REPRESENTATIVES, ST PRODUCTS ARE NOT RECOMMENDED, AUTHORIZED OR WARRANTED FOR USE IN MILITARY, AIR CRAFT, SPACE, LIFE SAVING, OR LIFE SUSTAINING APPLICATIONS, NOR IN PRODUCTS OR SYSTEMS WHERE FAILURE OR MALFUNCTION MAY RESULT IN PERSONAL INJURY, DEATH, OR SEVERE PROPERTY OR ENVIRONMENTAL DAMAGE. ST PRODUCTS WHICH ARE NOT SPECIFIED AS "AUTOMOTIVE GRADE" MAY ONLY BE USED IN AUTOMOTIVE APPLICATIONS AT USER'S OWN RISK.

Resale of ST products with provisions different from the statements and/or technical features set forth in this document shall immediately void any warranty granted by ST for the ST product or service described herein and shall not create or extend in any manner whatsoever, any liability of ST.

ST and the ST logo are trademarks or registered trademarks of ST in various countries.

Information in this document supersedes and replaces all information previously supplied.

The ST logo is a registered trademark of STMicroelectronics. All other names are the property of their respective owners.

© 2012 STMicroelectronics - All rights reserved

STMicroelectronics group of companies

Australia - Belgium - Brazil - Canada - China - Czech Republic - Finland - France - Germany - Hong Kong - India - Israel - Italy - Japan - Malaysia - Malta - Morocco - Philippines - Singapore - Spain - Sweden - Switzerland - United Kingdom - United States of America

www.st.com