

THIS DRAWING AND THE INFORMATION SET FORTH HERE-ON ARE THE PROPERTY OF TYCO ELECTRONICS, AND ARE TO BE HELD IN TRUST AND CONFIDENCE. PUBLICATION, DUPLICATION, DISCLOSURE, OR USE FOR ANY PURPOSE NOT EXPRESSLY AUTHORIZED IN WRITING BY TYCO ELECTRONICS IS PROHIBITED.

REVISIONS			
LTR	DESCRIPTION	DATE	APPROVED
N/C	INITIAL RELEASE PER ECN T-19787	1/13/95	R. H.
A	PER ECO-11-010998	May/26/2011	M.HIGGY

NOTES:



1. THIS DRAWING IS FOR THE PURPOSE OF PACKAGING THE KIT COMPONENTS IN A SEALED PLASTIC BAG.
2. THE COMPONENTS LISTED HEREON ARE IDENTIFIED WITH THEIR INDIVIDUAL PART NUMBER.
3. REFER TO THE INDIVIDUAL COMPONENT DRAWING FOR CONFIGURATION DETAILS.
4. THE KIT PACKAGE IS IDENTIFIED WITH THE KIT NUMBER.
5. THIS KIT CONSISTS OF:

ITEM	COMPONENT DRAWING NUMBER	DESCRIPTION	QTY
1	MTC100-JH2-P32	2 INCH HOUSING PLUG ASSY., CAD PLATED WITH CABLE CLAMP	1
2	MTC100-JA2-S11-T14	KIT, 2 INCH WAFER, "A" SOCKET (125°C), ROUND WIRE SolderSleeve® TERMINATORS	1
3	MTC100-JB2-S11-T16	KIT, 2 INCH WAFER, "B" SOCKET (125°C), ROUND WIRE SolderSleeve® TERMINATORS	1

If this document is printed it becomes uncontrolled. Check for the latest revision

Raychem MTC
CUSTOMER DRAWING

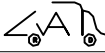
©2011 Tyco Electronics. All rights reserved.

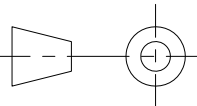
UNLESS OTHERWISE SPECIFIED DIMENSIONS ARE IN INCHES. METRIC DIMENSIONS ARE IN BRACKETS. DECIMALS .XXX ± [— mm] .XX ± [— mm] ANGLES .X — ± — WEIGHT: .10370 lbs [46,03 g]	DRAWN  1/11/95	 TE Connectivity			
	CHECKED R.H. 1/11/95				
	APPROVED HAGMANN 1/11/95				TITLE KIT, 2 INCH PLUG, CAD PLATED WITH CABLE CLAMP A AND B SOCKET WAFER 125 CELSIUS DEGREE ROUND WIRE SolderSleeve® TERMINATORS MTC100 SERIES
	APPROVED CAD NAME MTC100-KT2-0123-003				
THIRD ANGLE PROJECTION 	SIZE A CAGE CODE: 06090 SCALE: NONE	DWG. NO. MTC100-KT2-0123-003	REV A	SHEET 1 OF 1	