

NOTES:

1. METALSHELLS: STEEL; min. 315µm TIN over 40-80µm NICKEL
2. INSULATORS: PBT GF UL 94 V-0; BLACK
3. CONTACTS: COPPER ALLOY; PLATING (SEE PART NO.)
 - PLEASE ADD C for 30µm HARD GOLD over min. 50µm NICKEL
 - PLEASE ADD B for 20µm HARD GOLD over min. 50µm NICKEL
 - PLEASE ADD A for GOLD FLASH over NICKEL (PREFERRED TYPE)
4. METAL BRACKETS: ZINC DIE CAST; 300µm COPPER/40-120µm NICKEL/120-200µm TIN
5. THREADED INSERTS: COPPER ALLOY; min. 200µm TIN over 80µm NICKEL
6. PCB SNAPS: COPPER ALLOY; min. 200µm TIN over 80µm NICKEL
PCB-HOLE: Ø3.1±0.1; PCB THICKNESS 1.6mm
7. FIXING-PLATE: PBT GF UL 94 V-0; BLACK
8. MAXIMUM TORQUE VALUE FOR THREAD: 6 in.LB
9. CONNECTOR IS PART MARKED: **164□17989X CONEC ABC** (see note 3)

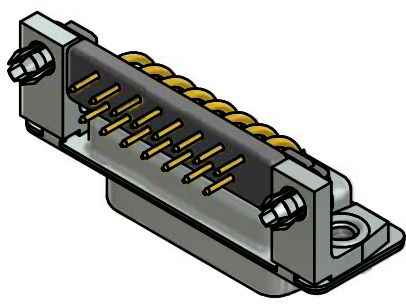

Directive 2002/95/EC RoHS compliant

THIS DRAWING MAY NOT BE COPIED OR REPRODUCED IN ANY WAY, AND MAY NOT BE PASSED ON TO A THIRD PARTY WITHOUT WRITTEN PERMISSION. OWNERSHIP AND COPYRIGHT OF CONEC GmbH DO NOT ALTER CAD DRAWING BY HAND	tolerance		dim. in mm	scale: 2:1 (5:1)		
				material: SEE NOTES		
	drawn	02.01.13	name		title: D-SUB FEMALE 90° 15pos. SOLDER PIN ANGLED 0.318inch with threaded insert, metal bracket and fixing-plate	
	appd.	03.01.13	name			
norm		d-old				
rev.	a	Original			dwg no:	DIN-A3
description					part no:	16K1A3160
date			part no:		164□17989X (see note 3)	