

REVISIONS				
P	LTR	DESCRIPTION	DATE	OWN APVD
L1	REV PER ECO-09-021826		09SEP09	KK AEG
L2	REVISED PER ECO-17-017495		04DEC2017	RS DR

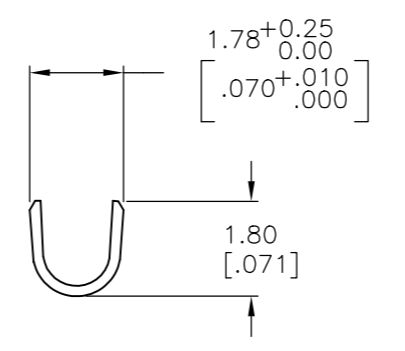

INSULATION RANGE: .048 MAX
SECTION D-D

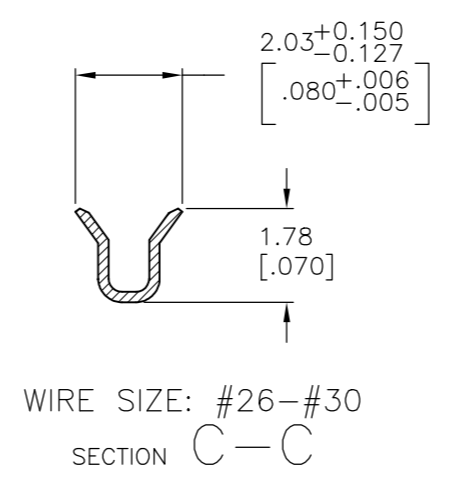
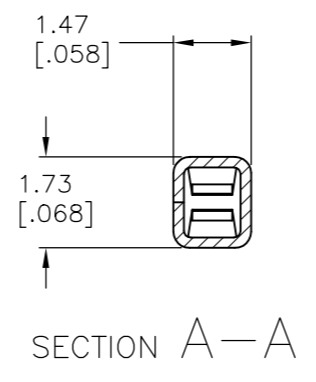
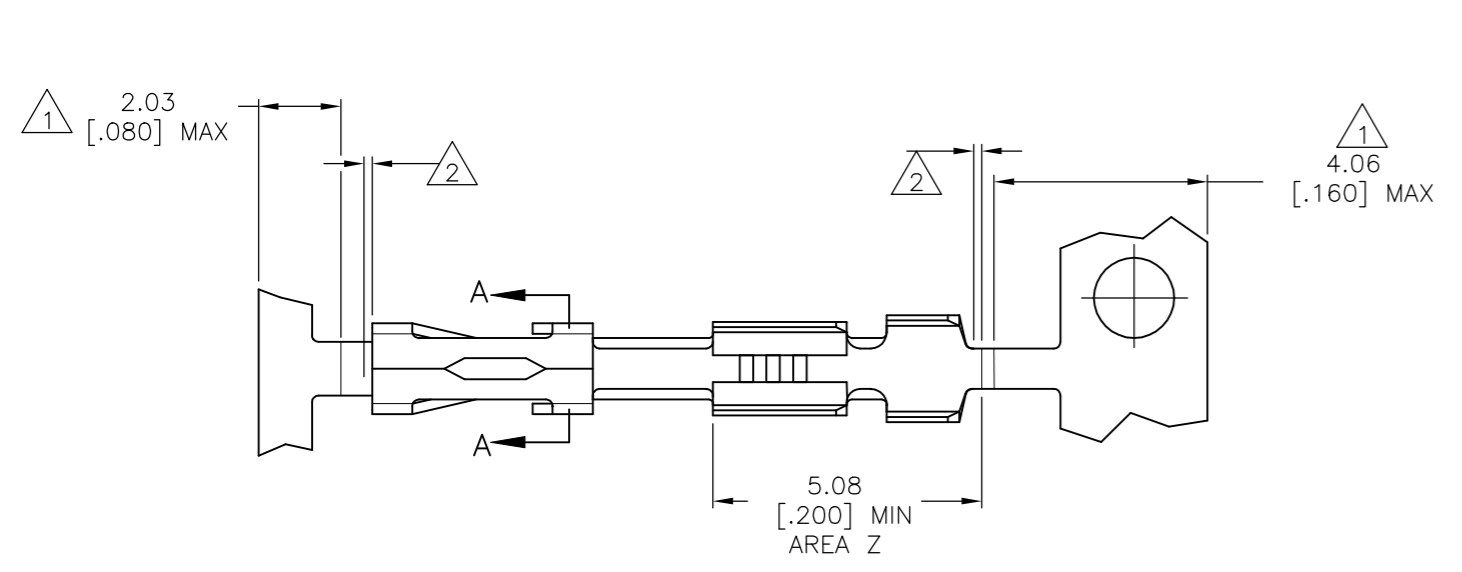
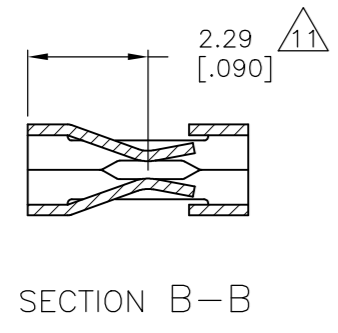
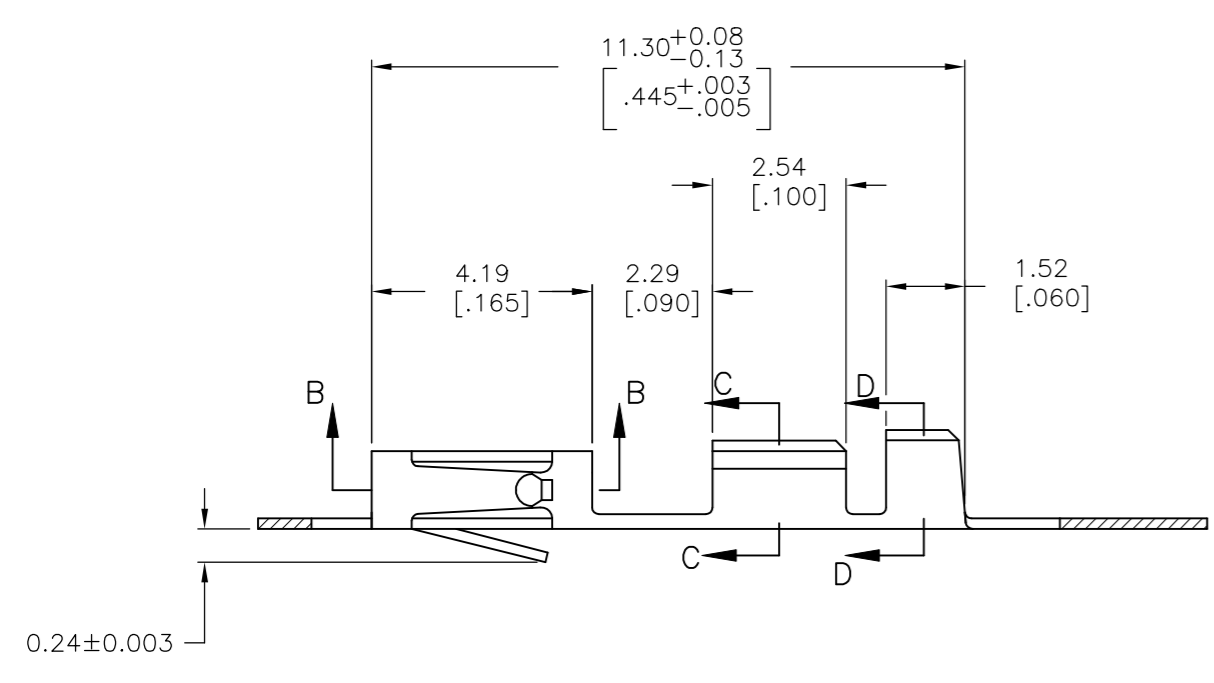

- 1 GOLD PLATING NOT REQUIRED IN THIS AREA.
- 2 .006 MAX LOOSE PIECE CUT OFF.
- 3 .000050-.000150 PREPLATED BRIGHT TIN.
- 4 .000030 GOLD IN CONTACT AREA, GOLD FLASH ON THE REMAINDER, OVER .000050 NICKEL.
- 5 .000030 GOLD OVER .000050 NICKEL, ENTIRE CONTACT.
- 6 .000050 GOLD OVER .000050 NICKEL, ENTIRE CONTACT.
- 7 .000015 GOLD IN CONTACT AREA, GOLD FLASH ON THE REMAINDER, OVER .000050 NICKEL.
- 8 .000015 GOLD IN CONTACT AREA, .000100 - .000200 BRIGHT TIN-LEAD IN AREA Z, ALL OVER .000050 NICKEL.
- 9 .000030 GOLD IN CONTACT AREA, .000100 - .000200 BRIGHT TIN-LEAD IN AREA Z, ALL OVER .000050 NICKEL.
- 10 SHEARED EDGES PERMITTED TO BE UNPLATED.
- 11 POINT OF MEASUREMENT FOR PLATING THICKNESS (INSIDE BEAMS).
- 12 OBSOLETE PART NUMBERS.
- 13 OBSOLETE PARTS: OBSOLETE CIS STREAMLINING PER D.RENAUD/D.SINISI

OBSOLETE	LOOSE PC	9	10	2-87313-1
OBSOLETE	MINI APPL	9	10	2-87313-0
OBSOLETE	LOOSE PC	8	10	1-87313-9
OBSOLETE	MINI APPL	8	10	1-87313-8
OBSOLETE	LOOSE PC	1	7	1-87313-7
OBSOLETE	LOOSE PC	1	6	1-87313-6
OBSOLETE	LOOSE PC	1	5	1-87313-5
OBSOLETE	LOOSE PC	1	4	1-87313-4
OBSOLETE	LOOSE PC	3		1-87313-3
OBSOLETE	MINI APPL	1	7	1-87313-2
OBSOLETE	MINI APPL	1	6	1-87313-1
OBSOLETE	MINI APPL	1	5	1-87313-0
OBSOLETE	MINI APPL	1	4	87313-9
OBSOLETE	MINI APPL	3		87313-8
OBSOLETE	STD APPL	-		87313-7
OBSOLETE	STD APPL	1	7	87313-6
OBSOLETE	STD APPL	1	6	87313-5
OBSOLETE	STD APPL	1	5	87313-4
OBSOLETE	STD APPL	1	4	87313-3
OBSOLETE	STD APPL	3		87313-2
OBSOLETE	STD APPL	3		87313-1

THIS DRAWING IS A CONTROLLED DOCUMENT. DIM: J.HERRINGTON 09DEC96
 DW: J.HERRINGTON 09DEC96
 APVD: J.HERRINGTON 09DEC96

TE Connectivity

CONTACT, MOD V, RECEPTACLE, CRIMP SNAP-IN

108-25007

114-25003

SIZE: A1 CAGE CODE: 00779 DRAWING NO: 87313

MATERIAL: PHOS BRONZE .008 THK. FINISH: SEE TABLE

CUSTOMER DRAWING

SCALE: NTS SHEET 1 OF 1 REV L2