

REV.	DATE	DESCRIPTION
NC	06/11/00	INITIAL RELEASE
A	07/01/04	UPDATE DRAWING FORMAT

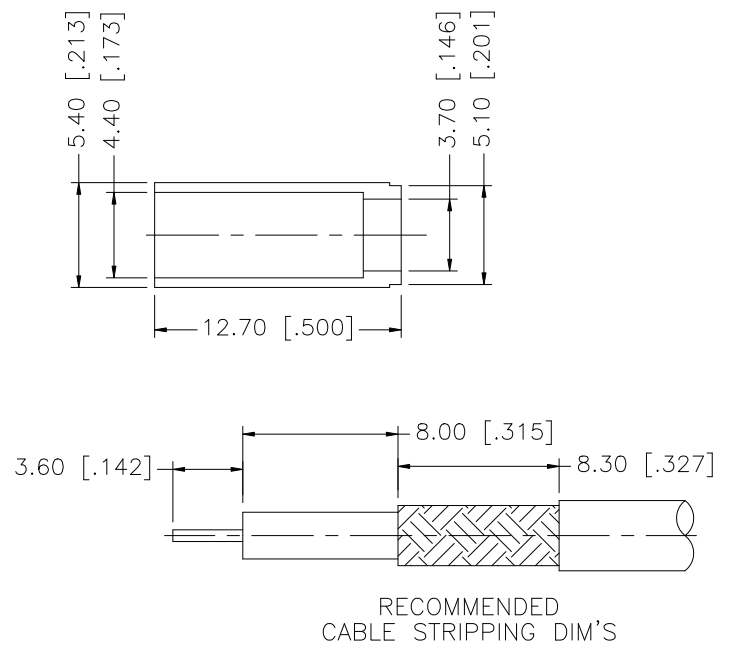
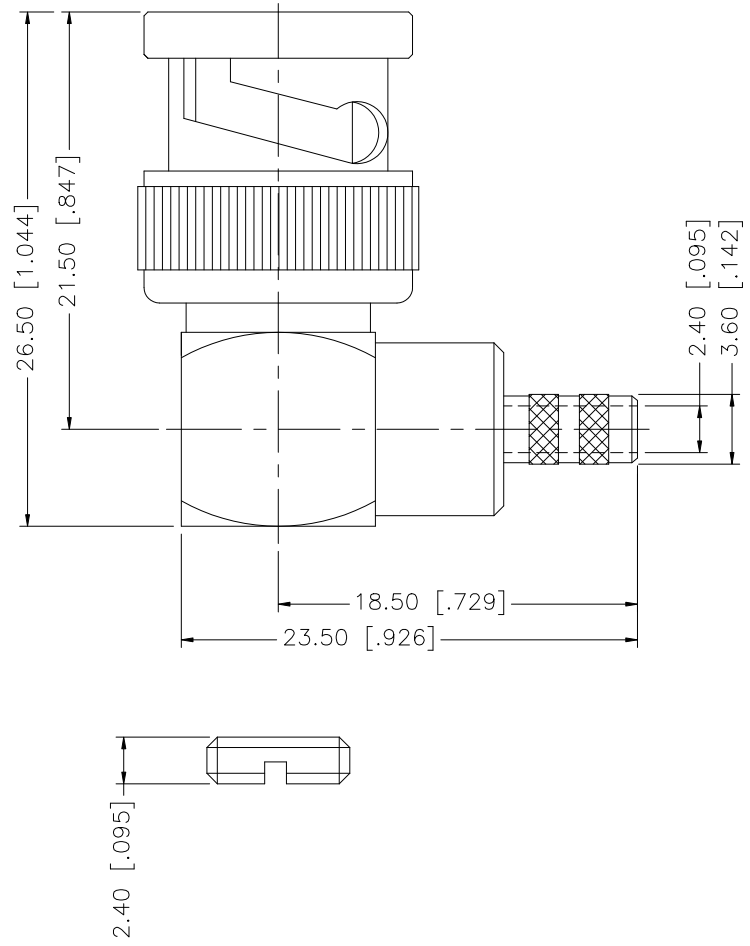

NOTES:
 1. CRIMPED FERRULE HEX CRIMP SIZE .187"

DESCRIPTION	MATERIAL	FINISH	QTY	
8				
7				
6				
5	NUT	BRASS	NICKEL	1
4	FERRULE	COPPER	NICKEL	1
3	CONTACT PIN	BRASS	GOLD	1
2	INSULATOR	TEFLON	NATURAL	1
1	BODY	BRASS	NICKEL	1

UNLESS OTHERWISE SPECIFIED DIMENSIONS ARE IN MILLIMETERS. DIMENSIONS IN [] ARE IN INCHES AND FOR CUSTOMER REFERENCE ONLY.

UNLESS OTHERWISE SPECIFIED TOLERANCES FOR MILLIMETERS ARE:
 0.5 - 8mm ± 0.20mm
 8 - 30mm ± 0.40mm
 30 - 120mm ± 0.50mm

UNLESS OTHERWISE SPECIFIED TOLERANCES FOR INCHES ARE:
 .020 - .315 = ± 0.007"
 .315 - 1.180 = ± 0.015"
 1.180 - 4.724 = ± 0.020"

DO NOT SCALE DRAWING

APPROVALS	DATE
DRAWN G.R.S.	07/01/04
CHECKED	
ISSUED	
SHEET 1 OF 1	
CAD FILE C:/112/112962.DWG	

Amphenol Connex

PART DESCRIPTION
**BNC R/A CRIMP PLUG
 (AT&T 735A CABLE)**

PART NO.
112962

DWG. NO. 112962.DWG REV. A SIZE A SCALE NA