

## Mechanical Dimensions: Inches [mm]

Tolerances  $\pm 0.012$  [0.3] Unless Otherwise Specified

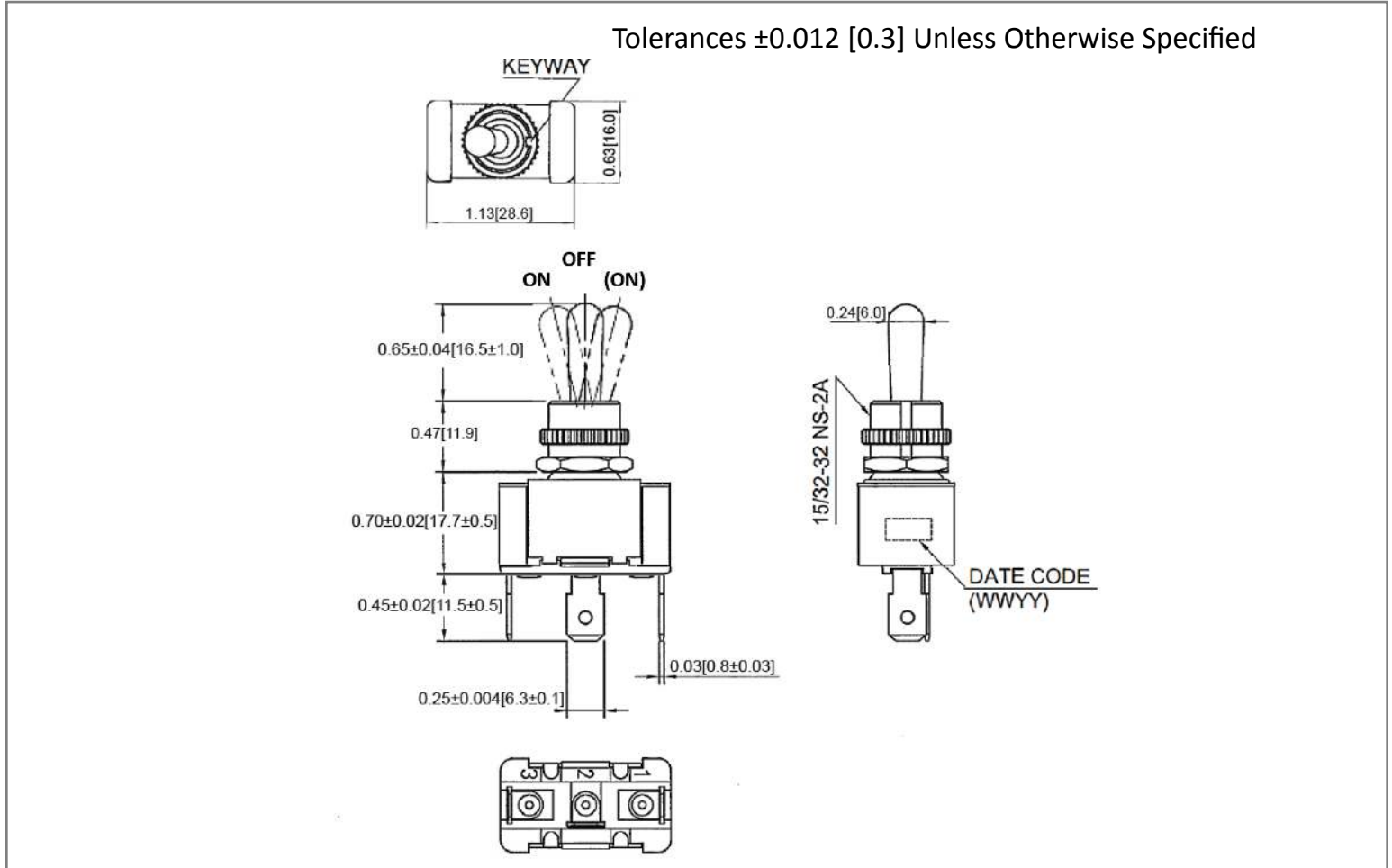

## Mounting Hole

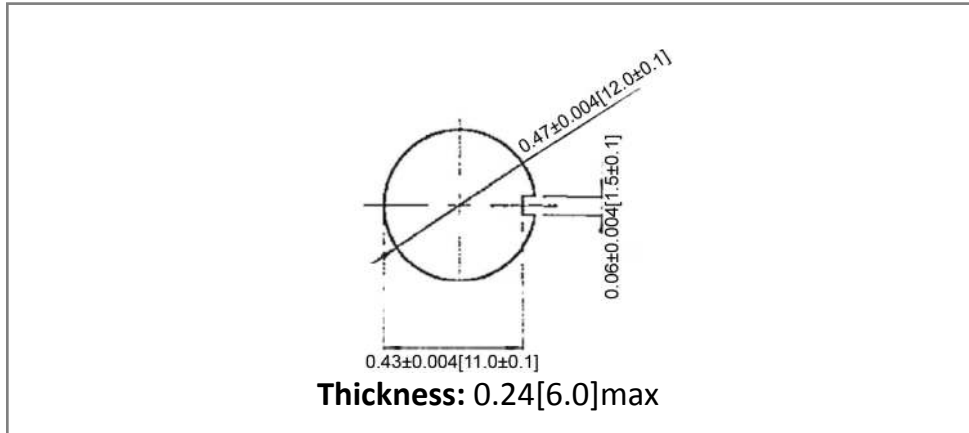

## Circuit Diagram

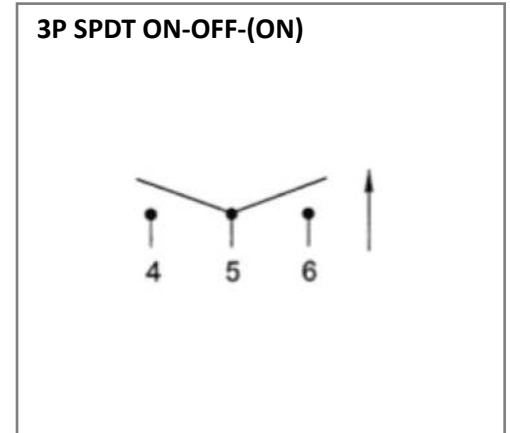

## Electrical Specifications

Rating	21A 14V DC
Contact Resistance	50m ohm Max
Insulation Resistance	DC 500V 100M ohm Min
Dielectric Strength	AC 1500V 1 minute
Operation Temperature	-20°C ~ 85°C

## Material Specifications

Operation Force	OFF-ON: 1100gf $\pm$ 300 gf, ON-OFF: 600gf $\pm$ 200 gf
	1 Hex Nut Assy
	1 Knurl Nut Assy

<b>Rev</b>	<b>Date of issue</b>	<b>Revision Notes</b>	<b>Designed</b>	<b>Approved</b>
B	03-04-2020	Initial Drawing	RC	OF