

## Low Output Voltage Low Dropout Regulator

### ■ GENERAL DESCRIPTION

The NJM2841 is a low output voltage, low dropout regulators.

It delivers up to 500mA output current with the output voltage of 0.8 to 2.5V.

The use of an external bias voltage can improve the transient response and the ripple rejection characteristics while maintaining minimum input to output voltage.

### ■ PACKAGE OUTLINE



NJM2841F

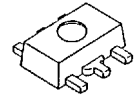

NJM2841U2

### ■ FEATURES

- Output Voltage Range 0.8V to 2.5V
- High Ripple Rejection 86 dB typ. ( $V_O=1.2V$  version)
- Output Noise Voltage  $V_{NO}=40\mu V_{rms}$  ( $V_O=1.2V$  version)
- Output Current  $I_O(\min)=500mA$
- High Precision Output  $V_O\pm 1.0\%$
- Dual Supply Voltage Type  $V_{IN}, V_{BIAS}$ (sequence free)
- High Stability for Load 0.002%/mA (max)
- Output Capacitor with 4.7 $\mu F$  ceramic capacitor
- Low Dropout Voltage 0.1V typ. @ $I_O=300mA$
- ON/OFF Control
- Built-in Thermal Overload Protection and Over Current Protection
- Bipolar Technology
- Package Outline SOT-23-5, SOT-89-5

### ■ PIN CONNECTION

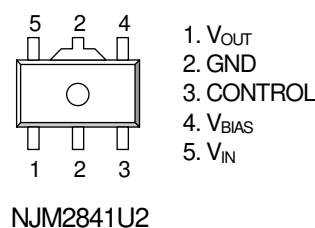
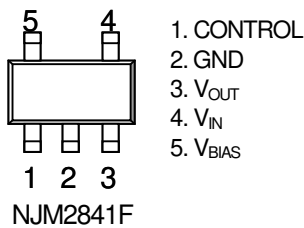

### ■ BLOCK DIAGRAM

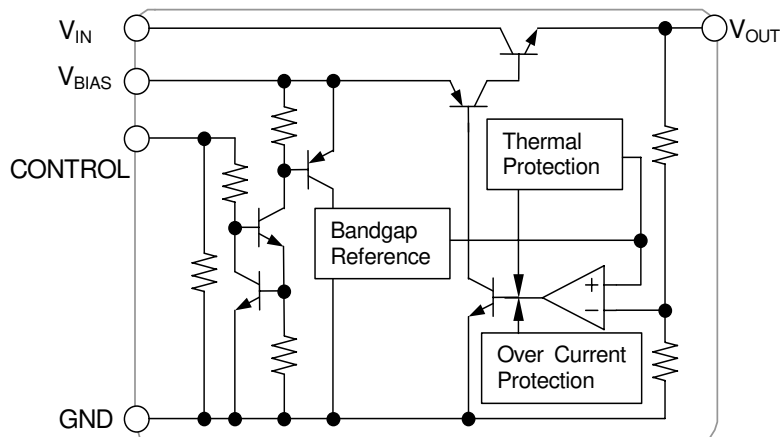

# NJM2841

## ■ OUTPUT VOLTAGE RANK LIST

Device Name	V <sub>out</sub>	Device Name	V <sub>out</sub>	Device Name	V <sub>out</sub>
NJM2841F008	0.8V	NJM2841F017	1.7V	NJM2841U2-012	1.2V
NJM2841F009	0.9V	NJM2841F018	1.8V		
NJM2841F010	1.0V	NJM2841F019	1.9V		
NJM2841F011	1.1V	NJM2841F020	2.0V		
NJM2841F012	1.2V	NJM2841F021	2.1V		
NJM2841F013	1.3V	NJM2841F022	2.2V		
NJM2841F014	1.4V	NJM2841F023	2.3V		
NJM2841F015	1.5V	NJM2841F024	2.4V		
NJM2841F016	1.6V	NJM2841F025	2.5V		

Output Voltage Range: 0.8V to 2.5V (0.1V step)

## ■ ABSOLUTE MAXIMUM RATINGS (Ta=25°C)

PARAMETER	SYMBOL	RATINGS	UNIT	
Input Voltage	V <sub>IN</sub>	+10	V	
Bias Voltage	V <sub>BIAS</sub>	+10	V	
Control Voltage	V <sub>CONT</sub>	+10	V	
Power Dissipation	P <sub>D</sub>	SOT-23-5	480(*1)	mW
			640(*2)	
		SOT-89-5	625(*3)	
			2400(*4)	
Operating Temperature	T <sub>opr</sub>	-40 ~ +85	°C	
Storage Temperature	T <sub>stg</sub>	-50 ~ +150	°C	

(\*1): Mounted on glass epoxy board. (76.2 × 114.3 × 1.6mm:based on EIA/JDEC standard, 2Layers)

(\*2): Mounted on glass epoxy board. (76.2 × 114.3 × 1.6mm:based on EIA/JDEC standard, 4Layers), internal Cu area: 74.2 × 74.2mm

(\*3): Mounted on glass epoxy board. (76.2 × 114.3 × 1.6mm:based on EIA/JDEC standard size, 2Layers, Cu area 100mm<sup>2</sup>)

(\*4): Mounted on glass epoxy board. (76.2 × 114.3 × 1.6mm:based on EIA/JDEC standard, 4Layers)

(For 4Layers: Applying 74.2 × 74.2mm inner Cu area and a thermal via hole to a board based on JEDEC standard JESD51-5)

## ■ BIAS VOLTAGE RANGE

V<sub>BIAS</sub>= +2.5V to +10V (V<sub>O</sub><1.5V)

V<sub>BIAS</sub>= V<sub>O</sub>+1V to +10V (V<sub>O</sub>≥1.5V)

## ■ ELECTRICAL CHARACTERISTICS

( $V_{BIAS}=2.5V(V_O \geq 1.5V) : V_{BIAS}=V_O+1V$ ,  $V_{IN}=V_O+1V$ ,  $C_{BIAS}=0.1\mu F$ ,  $C_{IN}=4.7\mu F$ ,  $C_O=4.7\mu F$ ,  $T_a=25^\circ C$ )

PARAMETER	SYMBOL	TEST CONDITION	MIN.	TYP.	MAX.	UNIT
Output Voltage	$V_O$	$I_O=30mA$	-1.0%	-	+1.0%	V
Unloaded Bias Current	$I_{BIAS}$	$I_O=0mA$ , except $I_{CONT}$	-	180	300	$\mu A$
Unloaded Input Current	$I_{IN}$	$I_O=0mA$ , except $I_{CONT}$	-	-	20	$\mu A$
Bias Current at Control OFF	$I_{BIAS(OFF)}$	$V_{CONT}=0V$	-	-	100	nA
Input Current at Control OFF	$I_{IN(OFF)}$	$V_{CONT}=0V$	-	-	100	nA
Output Current	$I_O$	$V_O \times 0.9V$	500	650	-	mA
Line Regulation 1 ( $V_{BIAS}$ )	$\Delta V_O / \Delta V_{BIAS}$	$V_{BIAS}=2.5V$ to $V_O+6V(V_O < 1.5V)$ $V_{BIAS}=V_O+1V$ to $V_O+6V(V_O \geq 1.5V)$ $I_O=30mA$	-	-	0.10	%/V
Line Regulation 2 ( $V_{IN}$ )	$\Delta V_O / \Delta V_{IN}$	$V_{IN}=V_O+1V$ to $V_O+6V$ , $I_O=30mA$	-	-	0.10	%/V
Load Regulation	$\Delta V_O / \Delta I_O$	$I_O=30$ to $500mA$	-	-	0.002	%/mA
Dropout Voltage	$\Delta V_{I-O}$	$I_O=300mA$	-	0.10	0.18	V
Ripple Rejection Ratio 1 ( $V_{BIAS}$ )	$RR1(V_{BIAS})$	$V_{BIAS}=3.5V$ , $e_{BIAS}=200mVrms$ , $f=1kHz$ , $I_O=10mA$	Refer to Table 1			dB
Ripple Rejection Ratio 2 ( $V_{IN}$ )	$RR2(V_{IN})$	$e_{IN}=200mVrms$ , $f=1kHz$ , $I_O=10mA$	Refer to Table 1			dB
Average Temperature Coefficient of Output Voltage	$\Delta V_O / \Delta T_a$	$T_a=0$ to $+85^\circ C$ , $I_O=10mA$	-	$\pm 50$	-	ppm/ $^\circ C$
Output Noise Voltage	$V_{NO}$	$f=10Hz$ to $80kHz$ , $I_O=10mA$	Refer to Table 1			$\mu Vrms$
Control Current	$I_{CONT}$	$V_{CONT}=1.6V$	-	3	12	$\mu A$
Control Voltage for ON-state	$V_{CONT(ON)}$		1.6	-	-	V
Control Voltage for OFF-state	$V_{CONT(OFF)}$		-	-	0.6	V
Bias Voltage	$V_{BIAS}$		-	-	10	V
Input Voltage	$V_{IN}$		-	-	9	V

• Table1

PARAMETER	SYMBOL	TEST CONDITION	MIN.	TYP.	MAX.	UNIT	
Ripple Rejection Ratio 1 ( $V_{BIAS}$ )	$RR(V_{BIAS})$	$V_{BIAS}=3.5V$ , $e_{BIAS}=200mVrms$ , $f=1kHz$ , $I_O=10mA$	$V_O=0.8V$	-	80	-	dB
			$V_O=0.9V$	-	80	-	
			$V_O=1.0V$	-	79	-	
			$V_O=1.2V$	-	77	-	
			$V_O=1.5V$	-	75	-	
		$V_{BIAS}=4.5V$ , $e_{BIAS}=200mVrms$ , $f=1kHz$ , $I_O=10mA$	$V_O=2.5V$	-	70	-	
Ripple Rejection Ratio 2 ( $V_{IN}$ )	$RR(V_{IN})$	$e_{in}=200mVrms$ , $f=1kHz$ , $I_O=10mA$	$V_O=0.8V$	-	87	-	dB
			$V_O=0.9V$	-	87	-	
			$V_O=1.0V$	-	87	-	
			$V_O=1.2V$	-	86	-	
			$V_O=1.5V$	-	85	-	
			$V_O=2.5V$	-	75	-	
Output Noise Voltage	$V_{NO}$	$f=10Hz \sim 80kHz$ , $I_O=10mA$ ,	$V_O=0.8V$	-	27	-	$\mu Vrms$
			$V_O=0.9V$	-	30	-	
			$V_O=1.0V$	-	34	-	
			$V_O=1.2V$	-	40	-	
			$V_O=1.5V$	-	48	-	
			$V_O=2.5V$	-	75	-	

## POWER DISSIPATION vs. AMBIENT TEMPERATURE

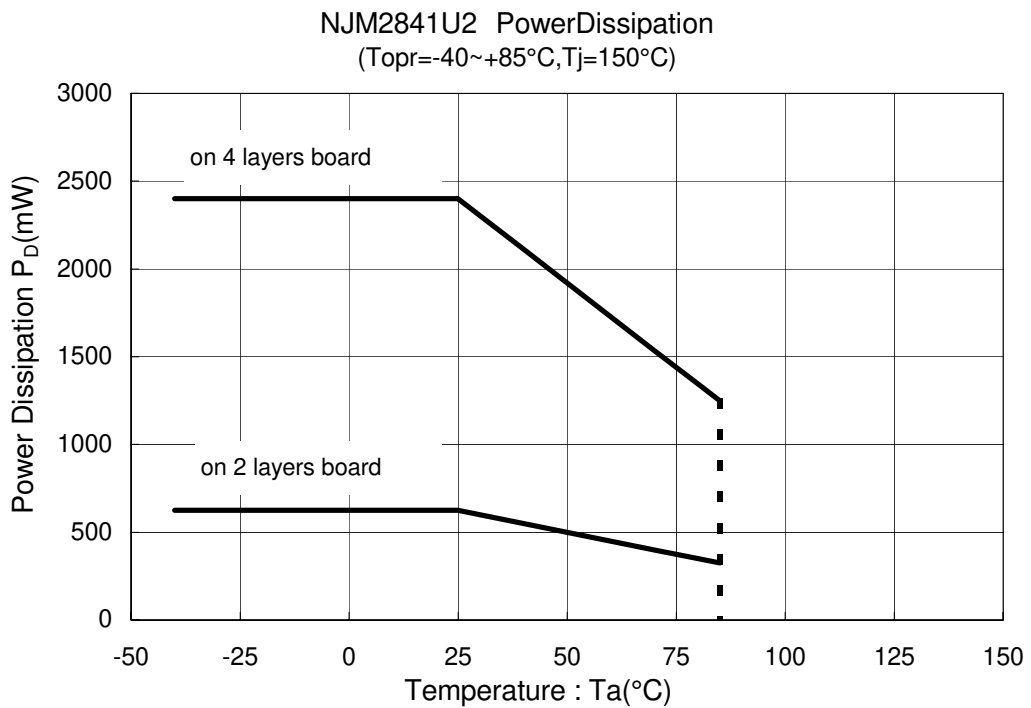
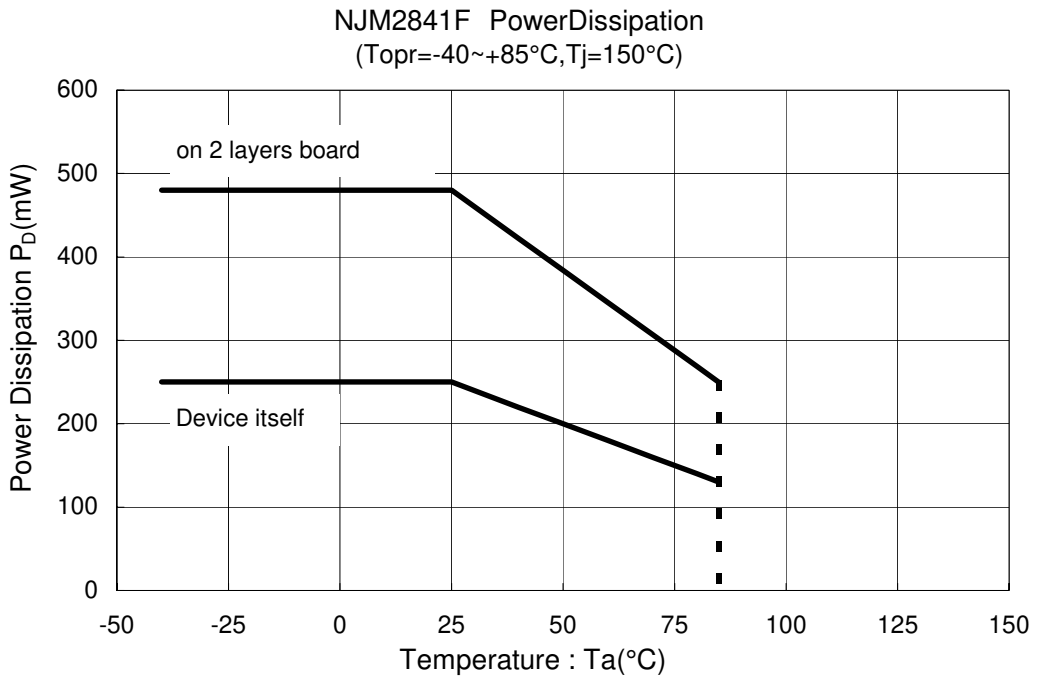

## TEST CIRCUIT

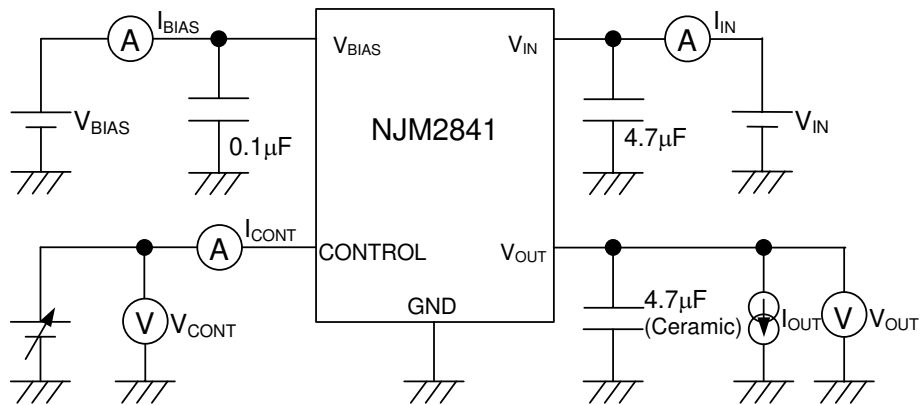

## TYPICAL APPLICATION

a) In case of where ON/OFF control is not required:

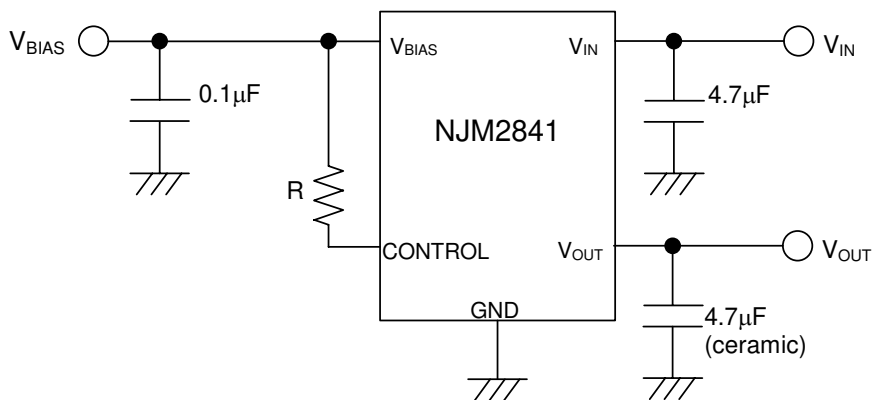

Connect control pin to  $V_{BIAS}$  pin.

Though the  $I_{CONT}$  decreases by inserting "R" to between Control pin and  $V_{BIAS}$  pin, the minimum operating voltage is increased due to the resistor "R".

b) In use of ON/OFF control:

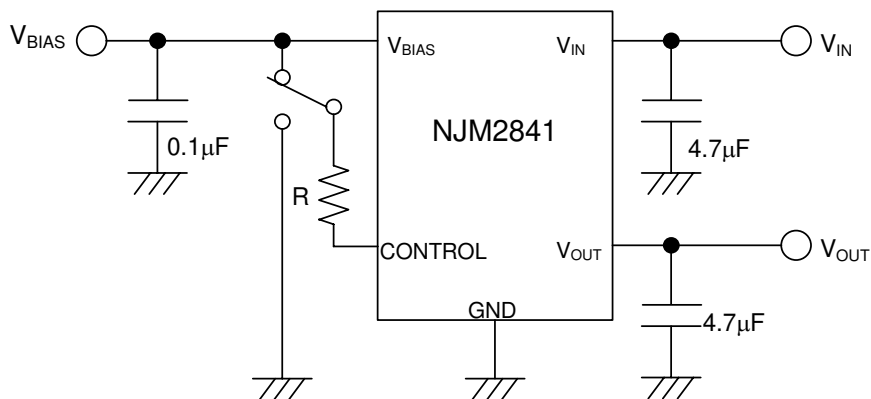

State of control pin:

"H" → output is enabled.

"L" or "open" → output is disabled.

\* Bias Capacitor  $C_{BIAS}$  and an Input Capacitor  $C_{IN}$

$C_{BIAS}$  and  $C_{IN}$  are required to prevent oscillation and reduce power supply ripple for applications when high power supply impedance or a long power supply line.

Therefore, use recommended  $C_{BIAS}$  and  $C_{IN}$  value (refer to conditions of ELECTRIC CHARACTERISTIC) or larger and should connect between  $V_{BIAS}$  - GND,  $V_{IN}$  - GND as shortest path as possible to avoid the problem.

\*Output Capacitor  $C_O$

Output capacitor ( $C_O$ ) will be required for a phase compensation of the internal error amplifier.

The capacitance and the equivalent series resistance (ESR) influence to stable operation of the regulator.

Use of a smaller  $C_O$  may cause excess output noise or oscillation of the regulator due to lack of the phase compensation.

On the other hand, Use of a larger  $C_O$  reduces output noise and ripple output, and also improves output transient response when rapid load change.

Therefore, use the recommended  $C_O$  value (refer to conditions of ELECTRIC CHARACTERISTIC) or larger and should connect between GND and  $V_{OUT}$  as shortest path as possible for stable operation

In addition, you should consider varied characteristics of capacitor (a frequency characteristic, a temperature characteristic, a DC bias characteristic and so on) and unevenness peculiar to a capacitor supplier enough.

When selecting  $C_O$ , recommend that have withstand voltage margin against output voltage and superior temperature characteristic though this product is designed stability works with wide range ESR of capacitor including low ESR products.

## ■ TYPICAL CHARACTERISTICS

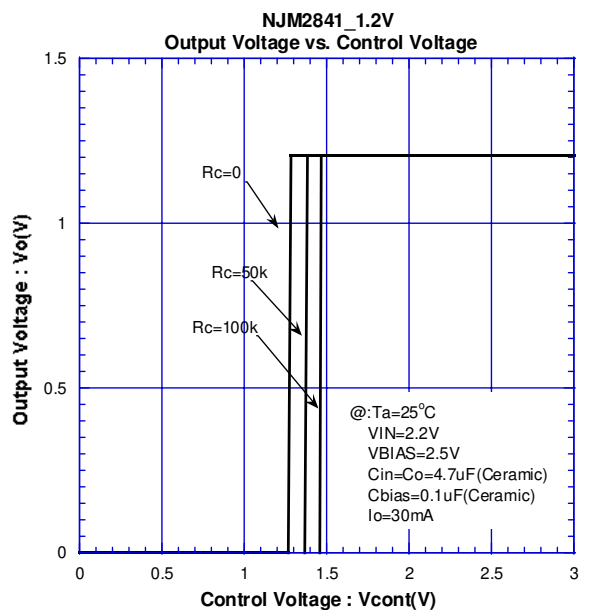
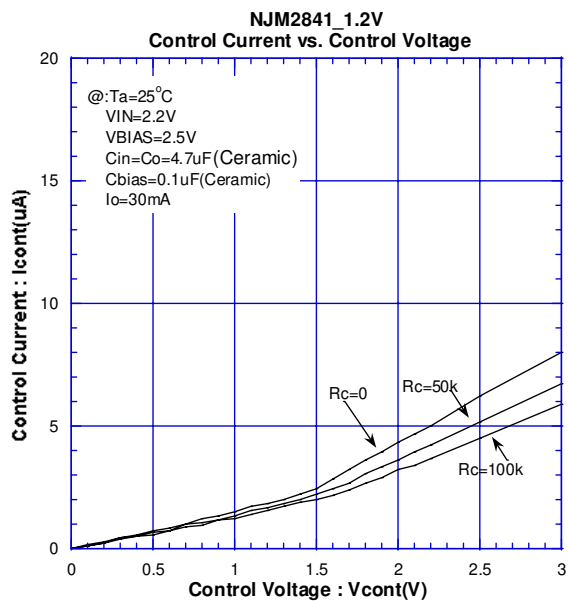
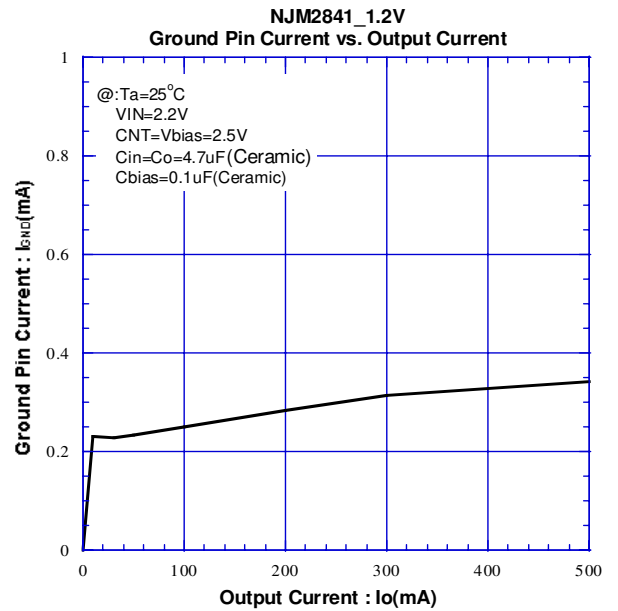
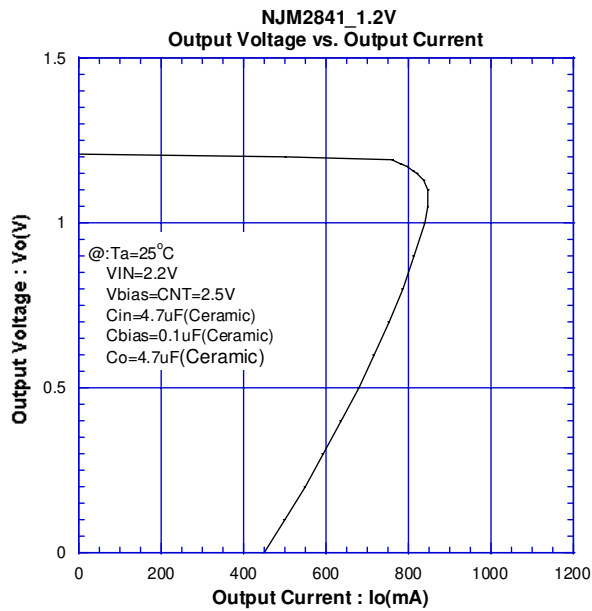
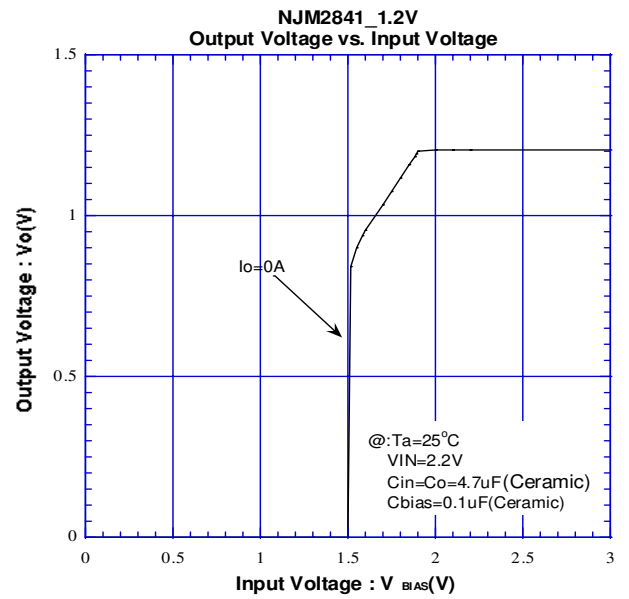
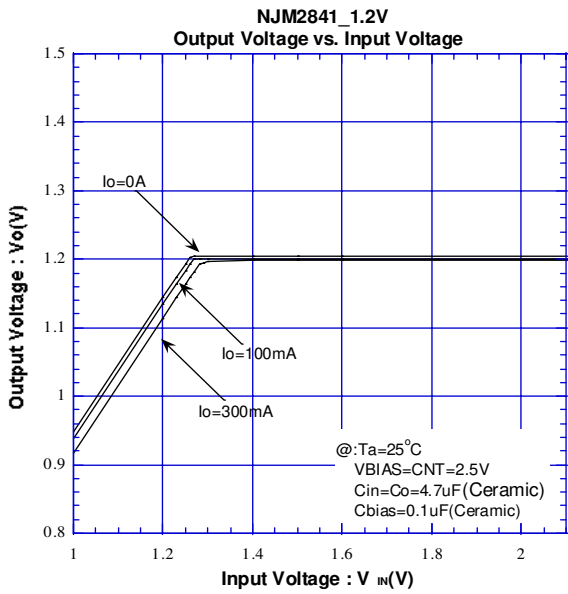

# NJM2841

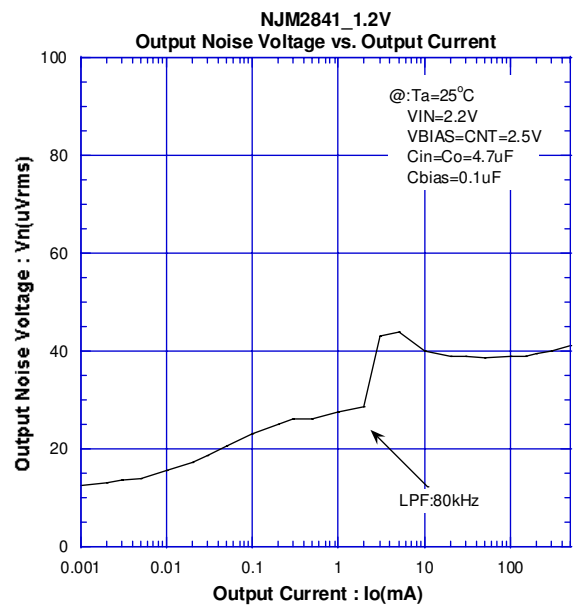
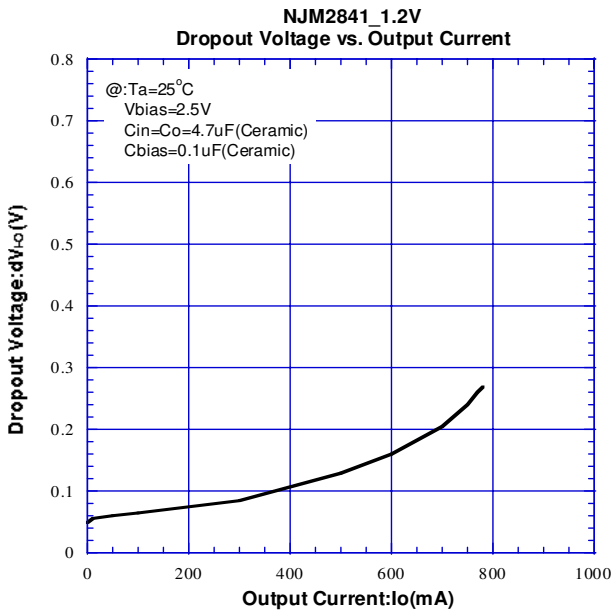
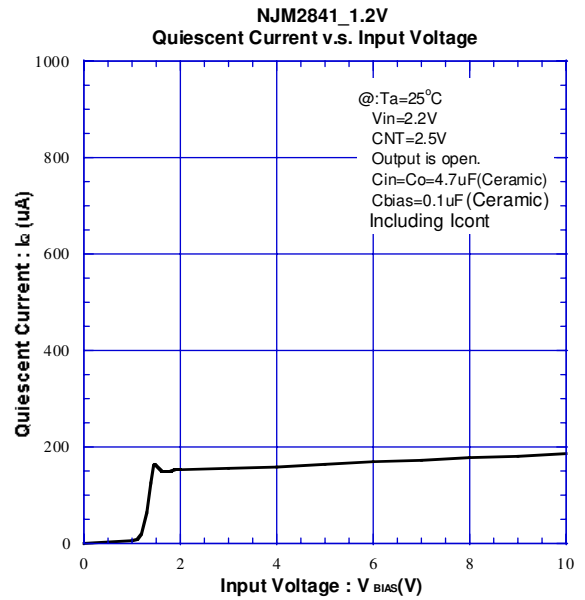
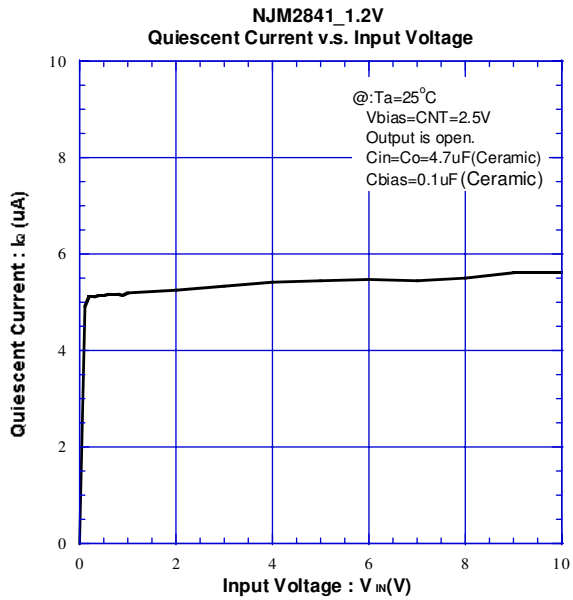
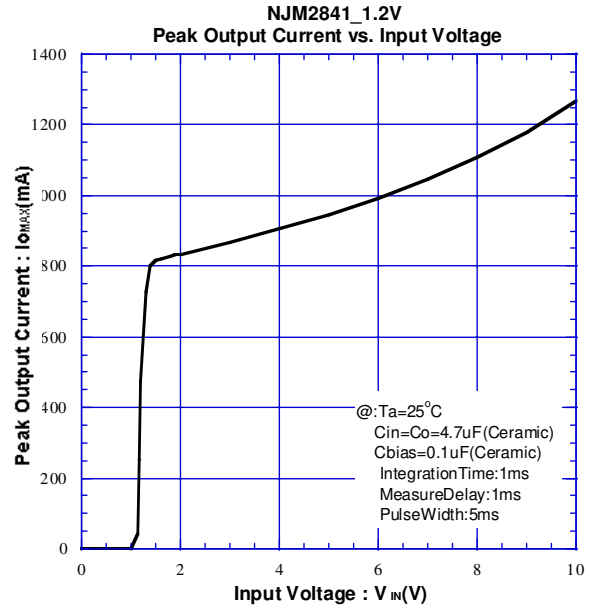
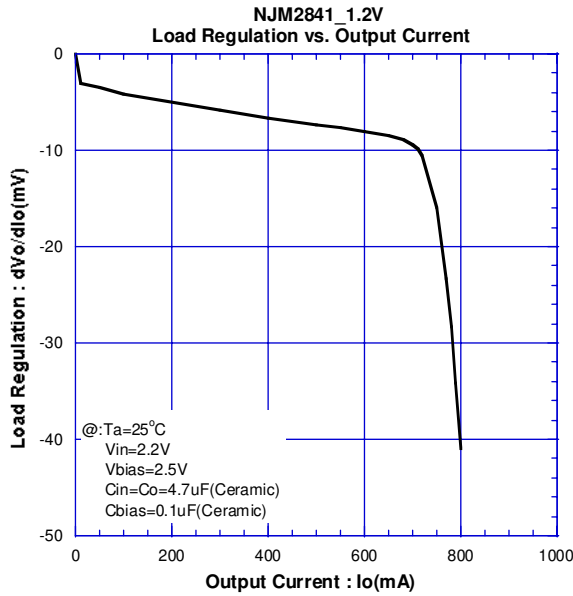



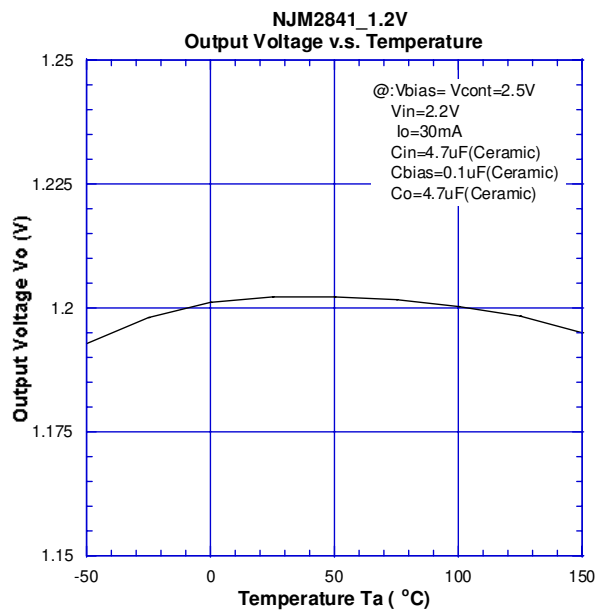
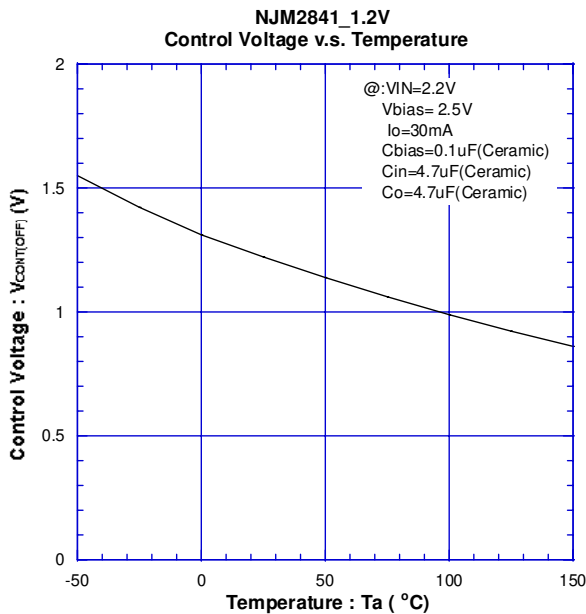
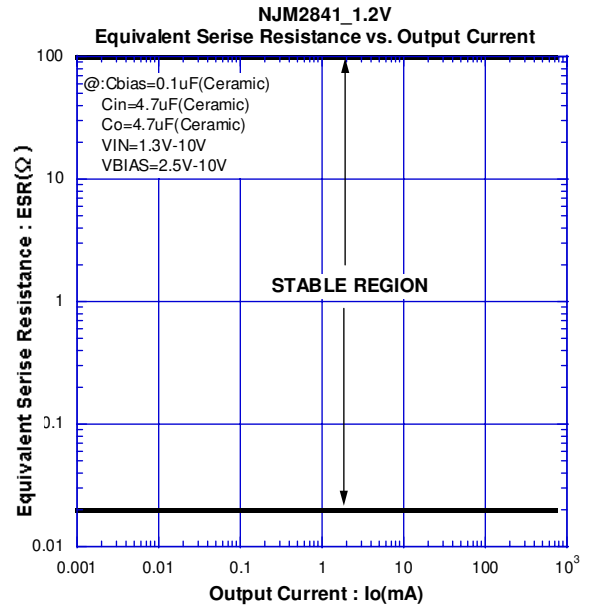
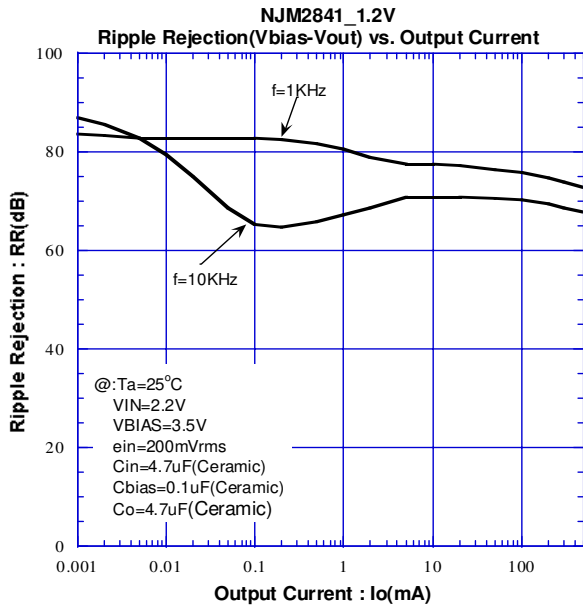
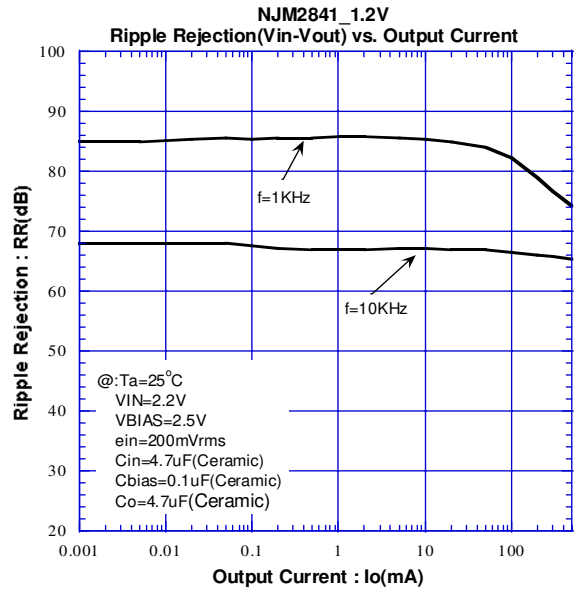
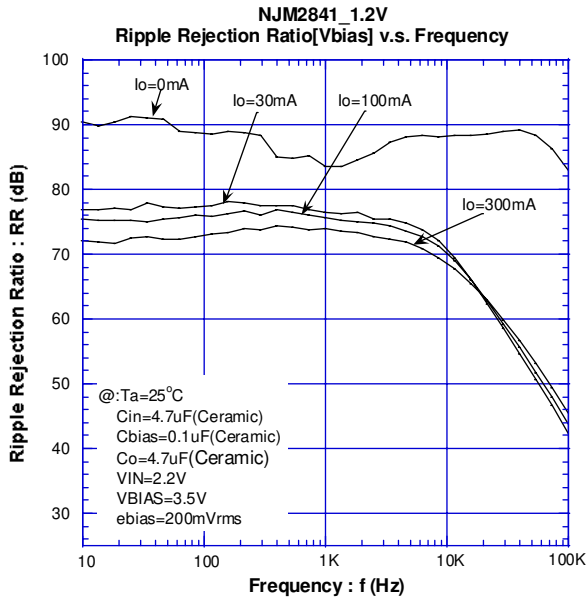

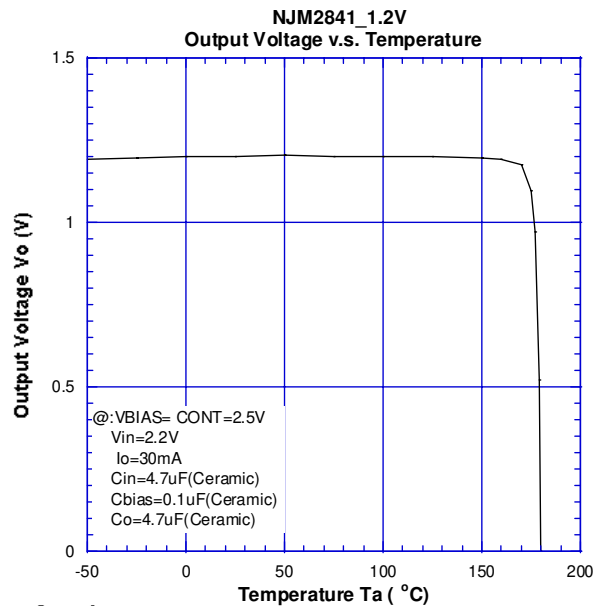
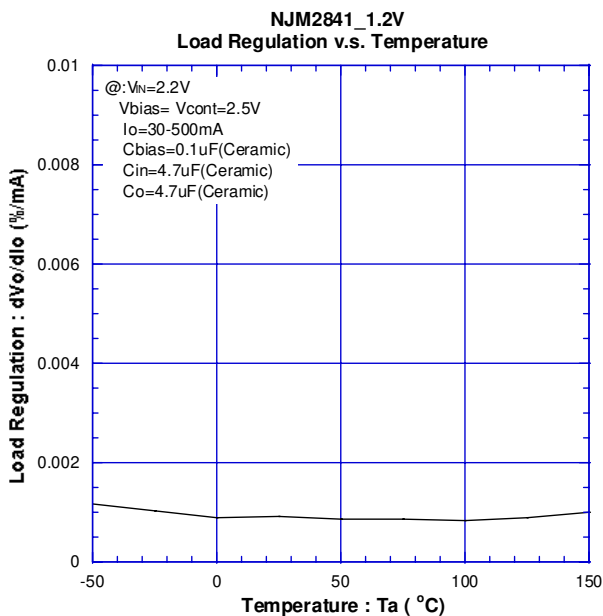
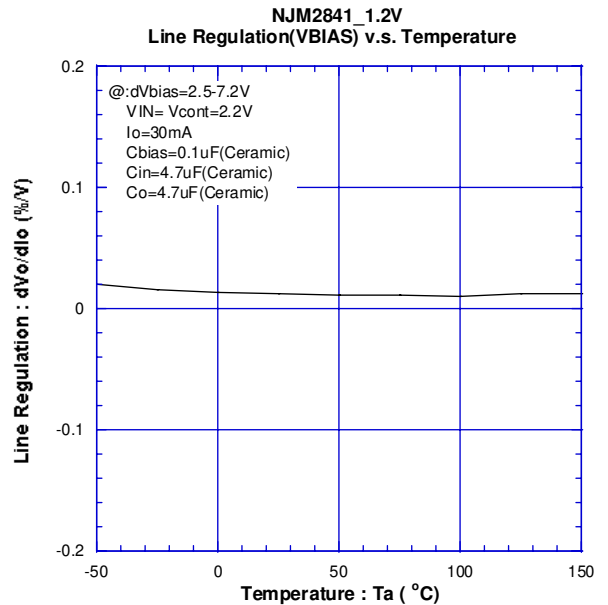
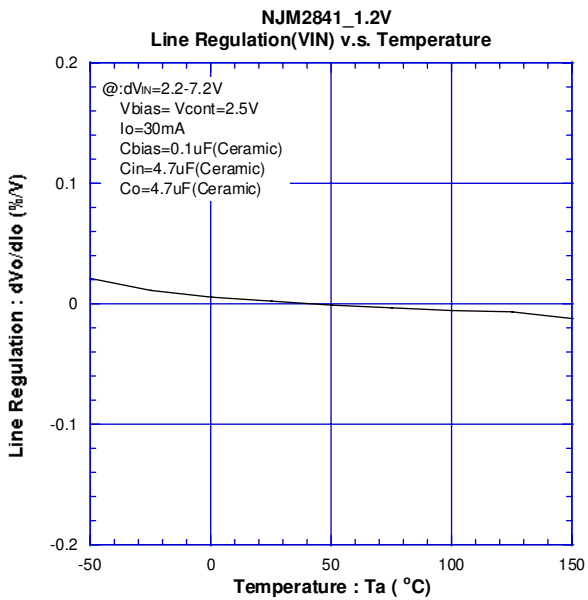
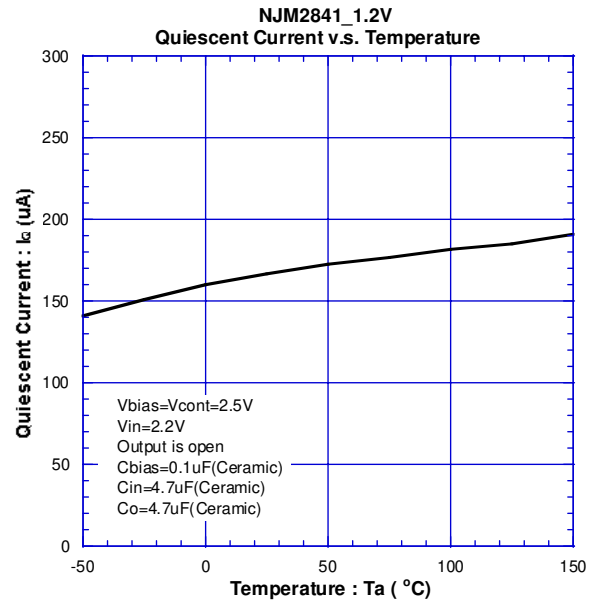
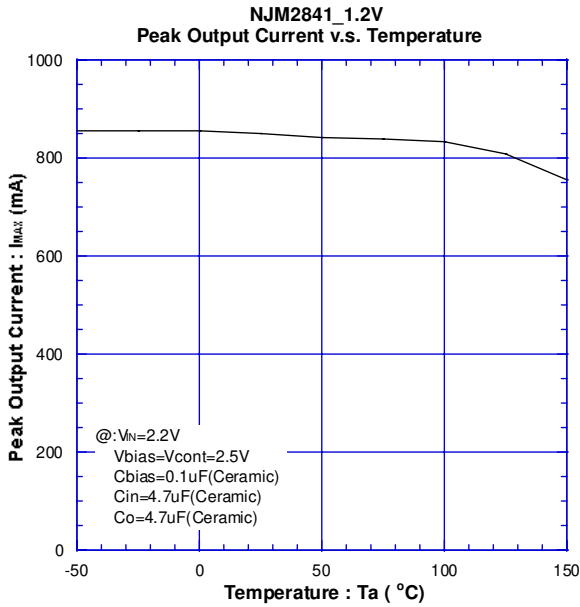

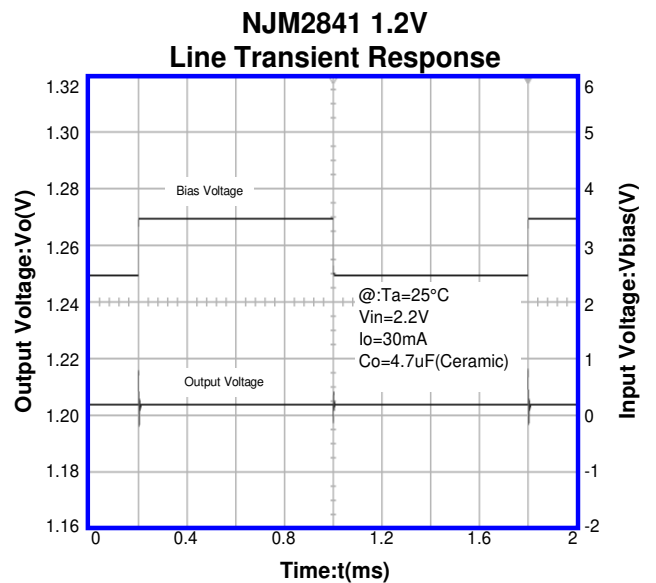
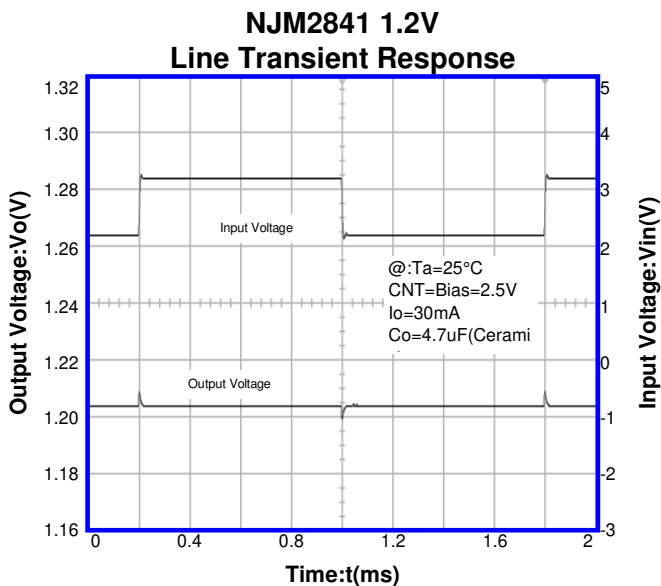
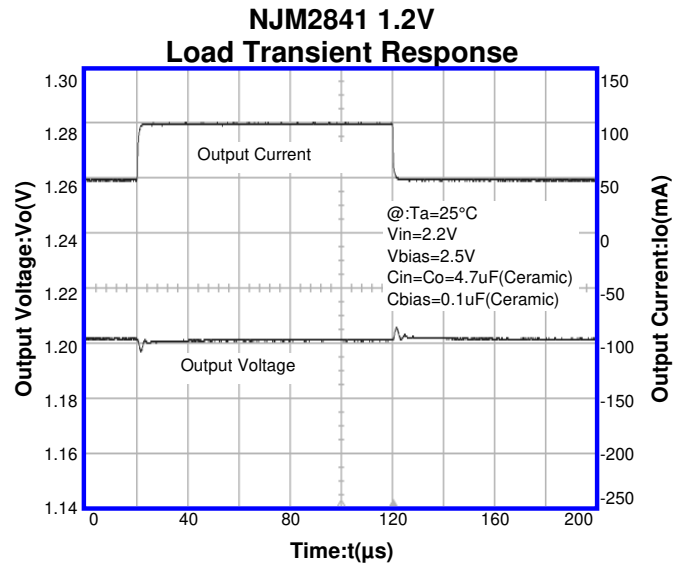
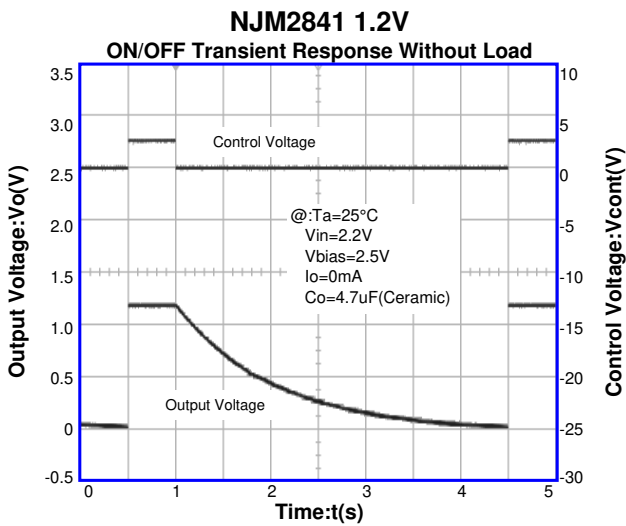
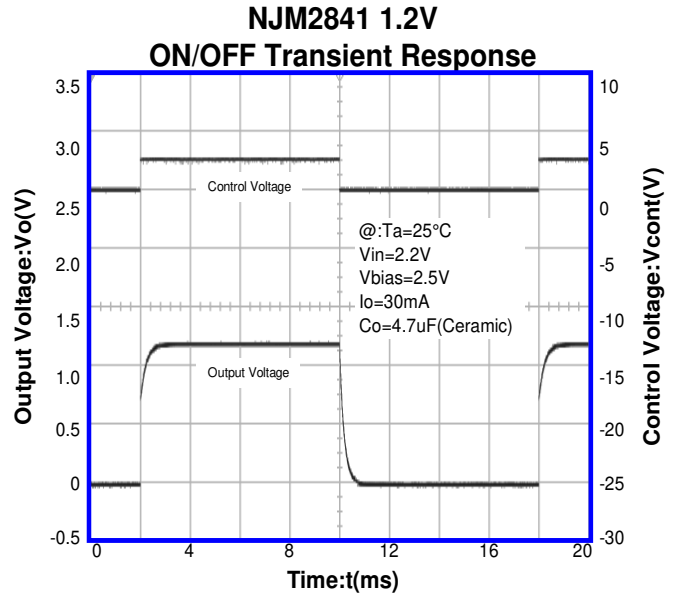
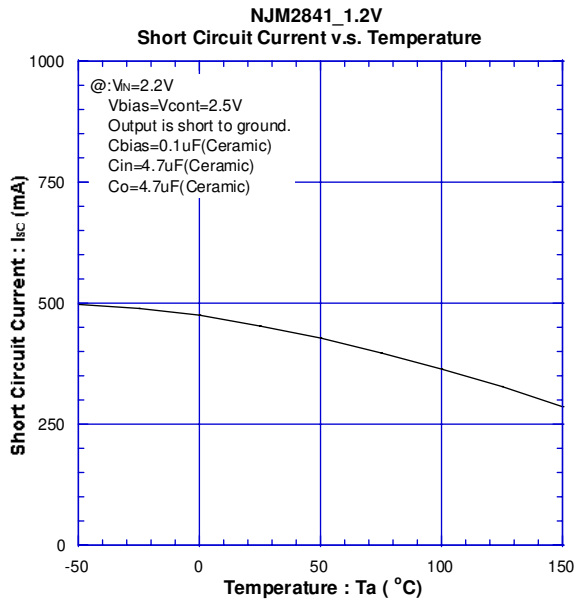

[CAUTION]

The specifications on this databook are only given for information, without any guarantee as regards either mistakes or omissions. The application circuits in this databook are described only to show representative usages of the product and not intended for the guarantee or permission of any right including the industrial rights.