



# **ORIENT DISPLAY**

Your Total LCD Solution Provider

## Specification for LCD Module

### AMC0802BR-B-Y6WFDY-I2C



Revision 00

AM	Orient Display
C	Character Type
0802	08 Characters x 02 Lines
B	Serial B, Module Dimension 58.0 x 32.0 x 14.0 (max)
R	RoHS Compliant
B	COB Type
Y	STN Positive Yellow-Green (Dark Character on Yellow Green Background)
6	6 o'clock Viewing Direction
W	Top: -20~+70°C; Tstr: -30~+80°C
F	Transflective
D	LED Backlight
Y	Yellow-Green Backlight
/	<a href="#">Controller AC780S or equivalent</a>
/	Serial I2C or IIC Interface



DOCUMENT REVISION HISTORY:

DATE	PAGE	DESCRIPTION
2013.2	-	First release

# **Contents**

1. Module Classification Information
2. Precautions in use of LCD Modules
3. General Specification
4. Absolute Maximum Ratings
5. Electrical Characteristics
6. Optical Characteristics
7. Interface Pin Function
8. Power Supply
9. Contour Drawing & Block Diagram
10. Function Description
11. Character Generator ROM Pattern
12. Instruction Table
13. Interface with MPU
14. Initializing of LCM
15. Quality Assurance
16. Reliability

# 1. Module Classification Information

**A M C 1 6 0 2 A R - B - B 6 W T D W - S P**  
 1 2 3 4 5 6 7 8 9 10 11 12 13

1	Brand : Orient Display	
2	Display Type : C→ Character Type, G→ Graphic Type, NONE→ Custom-made	
3	Display Font : Characters X Lines / Rows X Columns /Others	
4	Model serials no.	
5	RoHS compliant: R→YES NONE→ NO	
6	IC Package Type:	M→ SMT Type B→ COB Type T→ TAB Type G→ COG Type F→ COF Type S→ Special
7	LCD Mode:	P→TN Positive N→TN Negative Y→ STN Positive, Yellow Green B→ STN Negative, Blue G→ STN Positive, Gray W→ FSTN Positive T→ FSTN Negative F→ FFSTN Negative S→ Special
8	Viewing direction	6→ 6:00, 12→12:00, S→Special
9	Temperature range	N → Normal Temperature W→ Wide Temperature S→ Special
10	LCD Polarizer Type	R→ Reflective T→ Transmissive F→ Transflective S→ Special
11	Backlight Type	N→ None D→ LED E→ EL F→ CCFL S→ Special
12	Backlight Color	Y→ Yellow-green B→ Blue A→ Amber W→ White G→ Green R→ Red S→ Special
13	Internal Code	

## **2. Precautions in use of LCD Modules**

- (1) Avoid applying excessive shocks to the module or making any alterations or modifications to it.
- (2) Don't make extra holes on the printed circuit board, modify its shape or change the components of LCD module.
- (3) Don't disassemble the LCM.
- (4) Don't operate it above the absolute maximum rating.
- (5) Don't drop, bend or twist LCM.
- (6) Soldering: only to the I/O terminals.
- (7) Storage: please storage in anti-static electricity container and clean environment.

## **3. General Specification**

<b>Item</b>	<b>Dimension</b>	<b>Unit</b>
Number of Characters	8 characters x 2 Lines	—
Module dimension (With LED Backlight)	58.0 x 32.0 x 14.0 (MAX)	mm
View area	38.0 x 16.0	mm
Active area	27.81 x 11.50	mm
Dot size	0.56 x 0.66	mm
Dot pitch	0.60 x 0.70	mm
Character size	2.96 x 5.56	mm
Character pitch	3.55 x 5.94	mm
LCD type	STN, Transflective	
Duty	1/16	
View direction	6 o'clock	
Backlight Type	Yellow-Green/White LED backlight	

## 4. Absolute Maximum Ratings

Item		Symbol	Min	Max	Unit
Input Voltage		$V_I$	-0.3	$V_{DD}+0.3$	V
Supply Voltage For Logic		$V_{DD}-V_{SS}$	-0.3	5.5	V
Supply Voltage For LCD		$V_{DD}-V_0$	$V_{dd}-7.0$	$V_{dd}+0.3$	V
Wide Temperature LCM	Operating Temp.	Top	-20	70	°C
	Storage Temp.	Tstr	-30	80	°C

## 5. Electrical Characteristics

Item	Symbol	Condition	Min	Typ	Max	Unit
Supply Voltage For Logic	$V_{DD}-V_{SS}$	—	4.5	5.0	5.5	V
Supply Voltage For LCD	$V_{DD}-V_0$	$T_a=25^{\circ}\text{C}$	4.1	4.5	5.0	V
Input High Volt.	$V_{IH}$	—	$0.7 V_{DD}$	—	$V_{DD}$	V
Input Low Volt.	$V_{IL}$	—	$V_{SS}$	—	$0.3 V_{DD}$	V
Supply Current	$I_{DD}$	$V_{DD}=5\text{V}$	0.5	1.0	1.5	mA
Supply Voltage of Yellow-green backlight	$V_{LED}$	Forward current =60 mA  Number of LED die 2x6= 12	3.8	4.1	4.3	V
Supply Voltage of White LED backlight	$V_{LED}$	Forward current =15 mA  Number of LED die 1x1= 1	2.9	3.1	3.3	V

## 6. Optical Characteristics

Item	Symbol	Condition	Min	Typ	Max	Unit
View Angle	(V) $\theta$	$CR \geq 2$	-20	—	35	deg
	(H) $\phi$	$CR \geq 2$	-30	—	30	deg
Contrast Ratio	CR	—	—	3	—	—
Response Time	T rise	—	—	—	250	ms
	T fall	—	—	—	250	ms

### Definition of Operation Voltage (Vop)

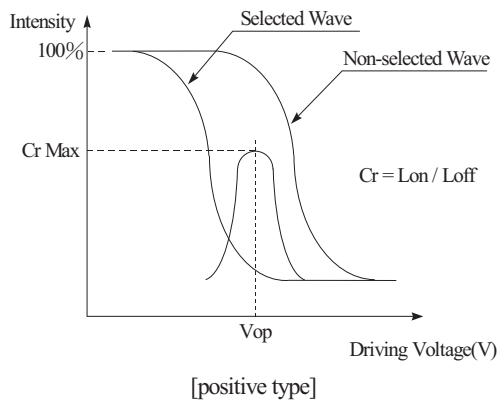

### Definition of Response Time (Tr, Tf)

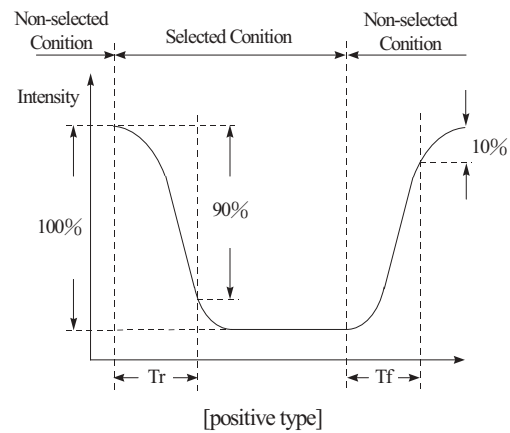

### Conditions:

Operating Voltage: Vop

Viewing Angle ( $\theta$ ,  $\phi$ ):  $0^\circ$ ,  $0^\circ$

Frame Frequency: 64 HZ

Driving Waveform: 1/N duty, 1/a bias

### Definition of viewing angle ( $CR \geq 2$ )

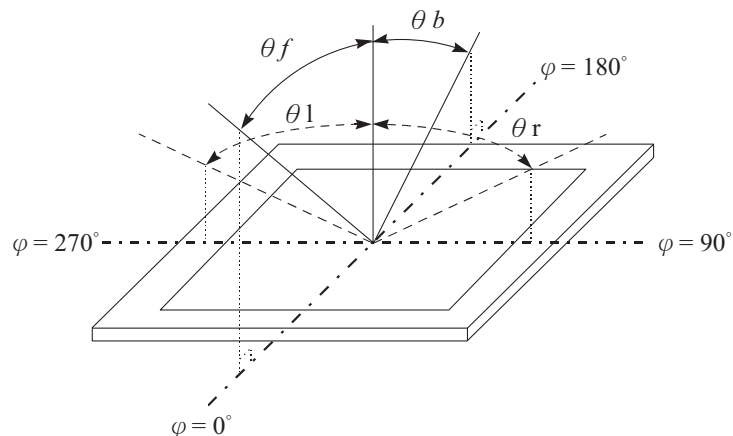

## **7. Interface Pin Function**

<b>Pin No.</b>	<b>Symbol</b>	<b>Level</b>	<b>Description</b>
1	LED(+)		Anode of LED Backlight
2	LED(-)		Cathode of LED Backlight
3	V <sub>SS</sub>	0V	Ground
4	V <sub>DD</sub>	5.0V	Supply Voltage for logic
5	SDA	H/L	Serial Data
6	SCL	H/L	Serial Clock
7	V <sub>0</sub>	(Variable)	Operating voltage for LCD
8	NC		No Connection
9	NC		No Connection
10	NC		No Connection



## 8. Power Supply

### SINGLE SUPPLY VOLTAGE TYPE

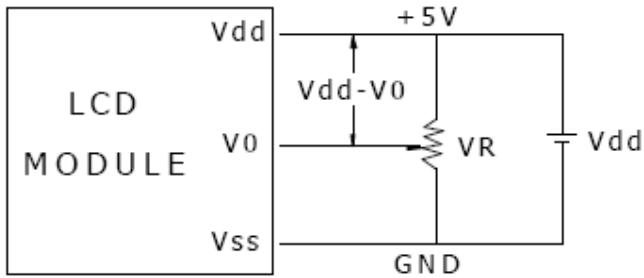

Vdd-V0: LCD Driving Voltage  
VR: 10K - 20K

### DUAL SUPPLY VOLTAGE TYPE

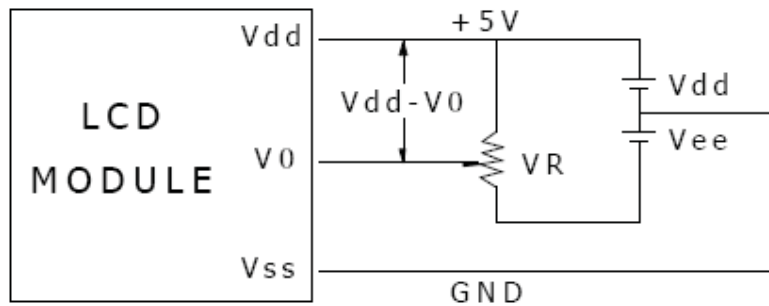

Vdd-V0: LCD Driving Voltage  
VR: 10K - 20K

### Timing Diagram of VDD Against V0.

Power on sequence shall meet the requirement of Figure 4, the timing diagram of VDD against V0.

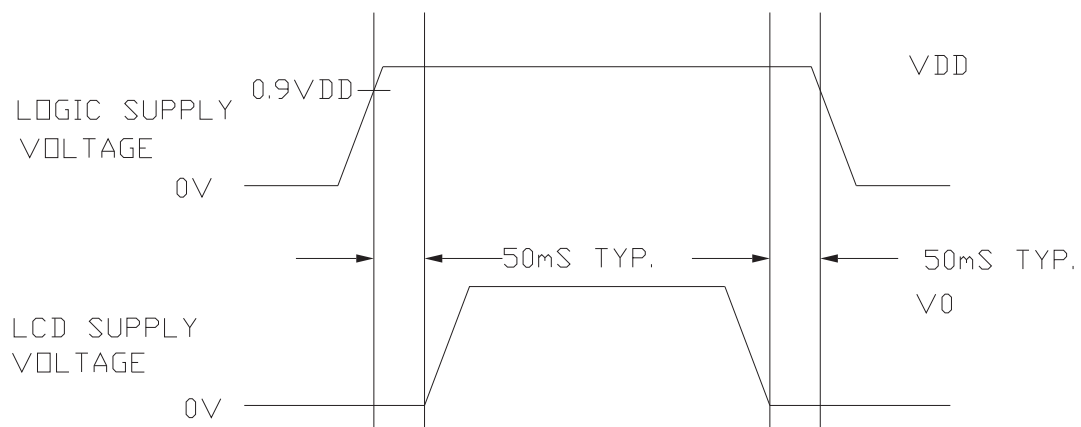

# 9. Contour Drawing & Block Diagram

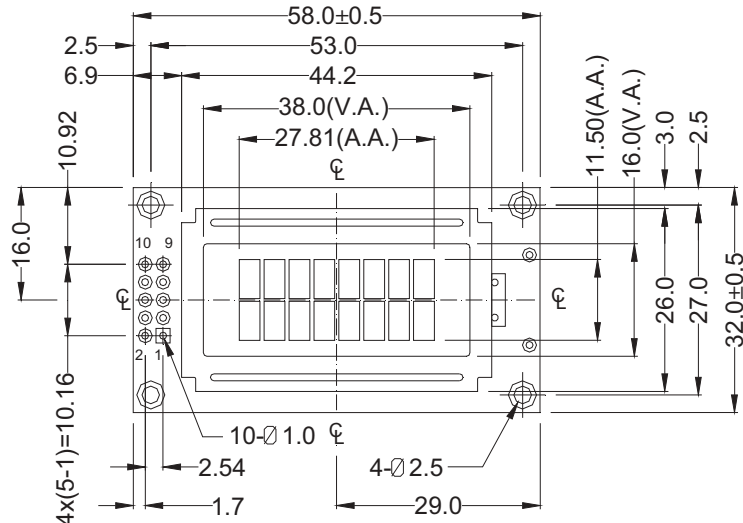

BOTTOM LIT LED B/L

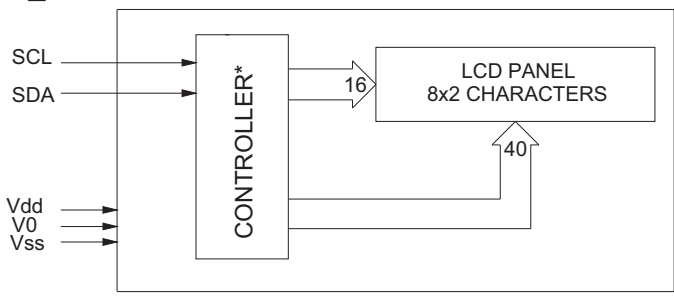
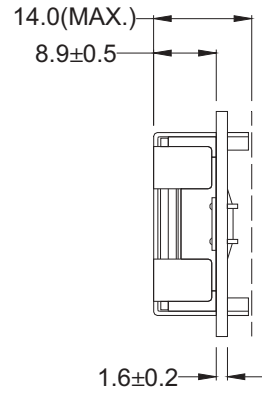

\*AC780S OR EQUIVALENT

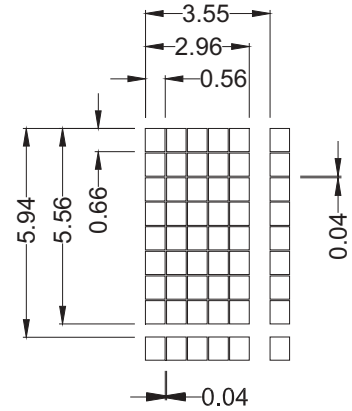

# 10. Function Description

The LCD display Module is built in a LSI controller, the controller has two 8-bit registers, an instruction register (IR) and a data register (DR).

The IR stores instruction codes, such as display clear and cursor shift, and address information for display data RAM (DDRAM) and character generator (CGRAM). The IR can only be written from the MPU. The DR temporarily stores data to be written or read from DDRAM or CGRAM. When address information is written into the IR, then data is stored into the DR from DDRAM or CGRAM.

## Address Counter (AC)

The address counter (AC) assigns addresses to both DDRAM and CGRAM

## Display Data RAM (DDRAM)

This DDRAM is used to store the display data represented in 8-bit character codes. Its extended capacity is 80×8 bits or 80 characters. Below figure is the relationships between DDRAM addresses and positions on the liquid crystal display.

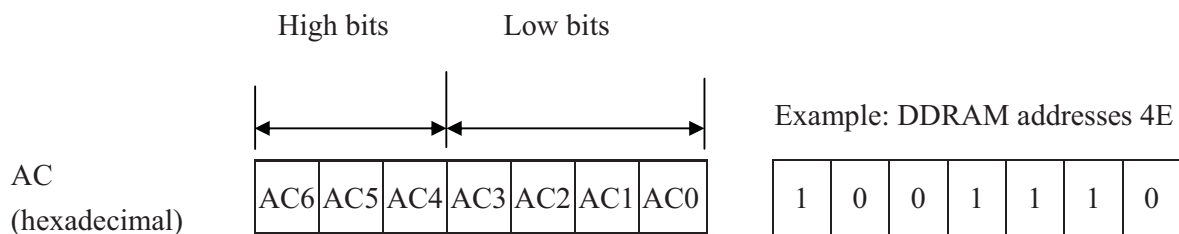

Display position DDRAM address

1 2 3 4 5 6 7 8

00	01	02	03	04	05	06	07
40	41	42	43	44	45	46	47

2-Line by 8 -Character Display

## Character Generator ROM (CGROM)

The CGROM generate 5×8 dot or 5×10 dot character patterns from 8-bit character codes. See Table 2.

## Character Generator RAM (CGRAM)

In CGRAM, the user can rewrite character by program. For 5×8 dots, eight character patterns can be written, and for 5×10 dots, four character patterns can be written.

Write into DDRAM the character code at the addresses shown as the left column of table 1. To show the character patterns stored in CGRAM.

# Relationship between CGRAM Addresses, Character Codes (DDRAM) and Character patterns

**Table 1**

For 5 \* 8 dot character patterns

Character Codes ( DDRAM data )								CGRAM Address						Character Patterns ( CGRAM data )											
7	6	5	4	3	2	1	0	5			4			3			2			1			0		
High				Low				High			Low			High				Low							
0 0 0 0 * 0 0 0								0 0 0						0 0 0	*	*	*	0				Character pattern( 1 )			
														0 0 1	*	*	*	0	0	0	Cursor pattern				
														0 1 0	*	*	*	0	0	0					
														0 1 1	*	*	*	0		0					
														1 0 0	*	*	*	0		0					
														1 0 1	*	*	*	0	0	0					
														1 1 0	*	*	*	0	0	0					
														1 1 1	*	*	*	0	0	0			0		
														0 0 0	*	*	*	0	0	0			0		
														0 0 1	*	*	*	0		0			0		
0 0 0 0 * 0 0 1								0 0 1						0 1 1	*	*	*	0	0	0		Character pattern( 2 )			
														1 0 0	*	*	*	0	0	0					
														1 0 1	*	*	*	0	0	0					
														1 1 0	*	*	*	0	0	0					
														1 1 1	*	*	*	0	0	0					
														0 0 0	*	*	*	0	0	0					
														0 1 0	*	*	*	0	0	0					
														0 1 1	*	*	*	0	0	0					
														1 0 0	*	*	*	0	0	0					
														1 0 1	*	*	*	0	0	0					
0 0 0 0 * 1 1 1								1 1 1						1 0 0	*	*	*					Cursor pattern			
														1 0 1	*	*	*								
														1 1 0	*	*	*								
														1 1 1	*	*	*								

For 5 \* 10 dot character patterns

Character Codes ( DDRAM data )										CGRAM Address						Character Patterns ( CGRAM data )																		
7	6	4		3	52	1	0	5			4			3			2			1			0											
High					Low					High			Low			High					Low													
0 0 0 0 * 0 0 0										0 0						0 0 0 0	*	*	*	0	0	0	0	0	0	Character pattern								
																0 0 0 1	*	*	*	0	0	0	0	0										
																0 0 1 0	*	*	*	0		0	0	0										
																0 0 1 1	*	*	*	0		0	0	0										
																0 1 0 0	*	*	*	0	0	0	0	0										
																0 1 0 1	*	*	*	0	0	0	0	0										
																0 1 1 0	*	*	*	0	0	0	0	0										
																0 1 1 1	*	*	*	0	0	0	0	0										
																1 0 0 0	*	*	*	0	0	0	0	0										
																1 0 0 1	*	*	*	0	0	0	0	0										
																1 0 1 0	*	*	*	0	0	0	0	0	Cursor pattern									
																1 1 1 1	*	*	*															
																										*	*	*						
																										*	*	*						

■ : " High "

# 11. Character Generator ROM Pattern

$\frac{b7 \rightarrow 4}{b3 \rightarrow 0}$		0000	0001	0010	0011	0100	0101	0110	0111	1000	1001	1010	1011	1100	1101	1110	1111
0000	CG RAM [00]			0	a	P	\	P				-	9	3	0	P	
0001	CG RAM [01]		!	1	A	Q	a	9			.	7	f	G	a	9	
0010	CG RAM [02]		"	2	B	R	b	r			7	/	9	x	P	a	
0011	CG RAM [03]		#	3	C	S	c	s			J	U	T	E	e	s	
0100	CG RAM [04]		\$	4	D	T	d	t			\	T	t	P	H	e	
0101	CG RAM [05]		%	5	E	U	e	u			-	*	*	1	e	U	
0110	CG RAM [06]		&	6	F	V	f	v			9	U	=	3	P	Z	
0111	CG RAM [07]		'	7	G	W	g	w			7	*	x	9	9	x	
1000	CG RAM [00]		(	8	H	X	h	x			4	U	*	U	J	X	
1001	CG RAM [01]		)	9	I	Y	i	y			6	T	J	U	'	Y	
1010	CG RAM [02]		*	*	J	Z	j	z			x	U	U	U	U	J	*
1011	CG RAM [03]		+	+	K	k	k	k			*	T	U	U	*	k	
1100	CG RAM [04]		,	<	L	l	l	l			P	U	U	U	U	U	
1101	CG RAM [05]		-	=	M	m	m	m			u	x	s	U	U	*	
1110	CG RAM [06]		.	>	N	n	n	n			a	U	U	U	U	n	
1111	CG RAM [07]		/	?	O	o	o	e			u	U	U	U	U	U	■

## 12. Instruction Table

Instruction	Instruction Code										Description	Execution time (fosc=210Khz)
	RS	R/W	DB7	DB6	DB5	DB4	DB3	DB2	DB1	DB0		
Clear Display	0	0	0	0	0	0	0	0	0	1	Write "20H" to DDRAM and set DDRAM address to "00H" from AC	1.98ms
Return Home	0	0	0	0	0	0	0	0	1	—	Set DDRAM address to "00H" from AC and return cursor to its original position if shifted. The contents of DDRAM are not changed.	1.98ms
Entry Mode Set	0	0	0	0	0	0	0	1	I/D	SH	Assign cursor moving direction and enable the shift of entire display.	48μs
Display ON/OFF	0	0	0	0	0	0	1	D	C	B	Set display (D), cursor (C), and blinking of cursor (B) on/off control bit.	48μs
Cursor or Display Shift	0	0	0	0	0	1	S/C	R/L	—	—	Set cursor moving and display shift control bit, and the direction, without changing of DDRAM data.	48μs
Function Set	0	0	0	0	1	DL	N	F	—	—	Set interface data length (DL:8-bit/4-bit), numbers of display line (N:2-line/1-line)and, display font type (F:5×11 dots/5×8 dots)	48μs
Set CGRAM Address	0	0	0	1	AC5	AC4	AC3	AC2	AC1	AC0	Set CGRAM address in address counter.	48μs
Set DDRAM Address	0	0	1	AC6	AC5	AC4	AC3	AC2	AC1	AC0	Set DDRAM address in address counter.	48μs
Write Data to RAM	1	0	D7	D6	D5	D4	D3	D2	D1	D0	Write data into internal RAM (DDRAM/CGRAM).	48μs

\* "—" : N/A

# 13. Interface with MPU

- For serial interface data, bus lines (DB5(CSB) , DB6(SDA) and DB7(SCL)) are used.  
**I2C interface**

The I2C interface receives and executes the commands sent via the I2C Interface. It also receives RAM data and sends it to the RAM.

The I2C Interface is for bi-directional, two-line communication between different ICs or modules. Serial data line SDA (DB6) and a Serial clock line SCL (DB7) must be connected to a positive supply via a pull-up resistor.

Data transfer may be initiated only when the bus is not busy.

\*The CSB (DB5) Pin must be setting to “VSS”.

\* When I2C interface is selected, the DL register must be set to “1”.

### ➤ BIT TRANSFER

One data bit is transferred during each clock pulse. The data on the SDA line must remain stable during the HIGH period of the clock pulse because changes in the data line at this time will be interpreted as a control signal. Bit transfer is illustrated in Fig.9.1

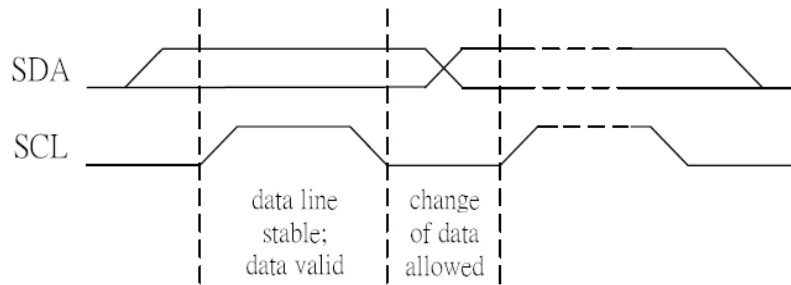

Fig .9.1 Bit transfer

### ➤ START AND STOP CONDITIONS

Both data and clock lines remain HIGH when the bus is not busy. A HIGH-to-LOW transition of the data line, while the clock is HIGH is defined as the START condition (S). A LOW-to-HIGH transition of the data line while the clock is HIGH is defined as the STOP condition (P). The START and STOP conditions are illustrated in Fig.9.2

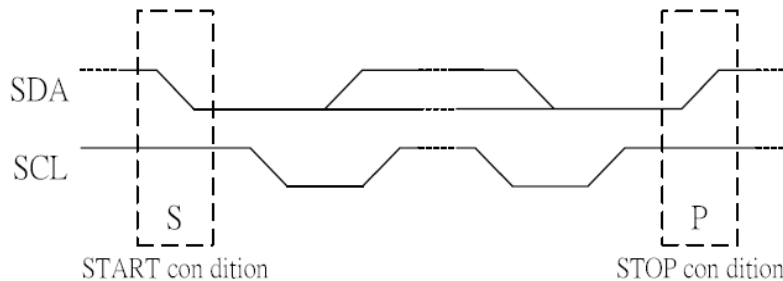

Fig .9.2 Definition of START and STOP conditions

## ➤ SYSTEM CONFIGURATION

The system configuration is illustrated in Fig.9.3

- Transmitter: the device, which sends the data to the bus
- Receiver: the device, which receives the data from the bus
- Master: the device, which initiates a transfer, generates clock signals and terminates a transfer
- Slave: the device addressed by a master
- Multi-Master: more than one master can attempt to control the bus at the same time without corrupting the message
- Arbitration: procedure to ensure that, if more than one master simultaneously tries to control the bus, only one is allowed to do so and the message is not corrupted
- Synchronization: procedure to synchronize the clock signals of two or more devices.

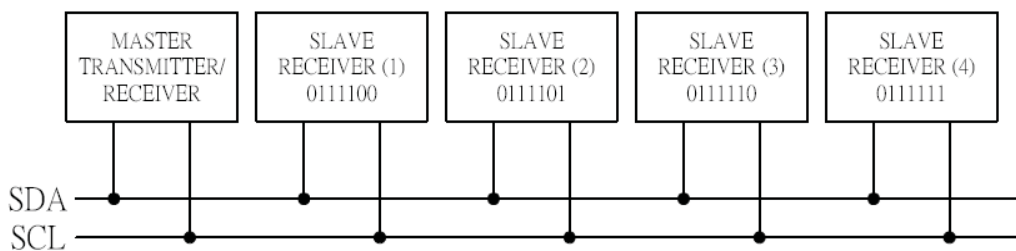
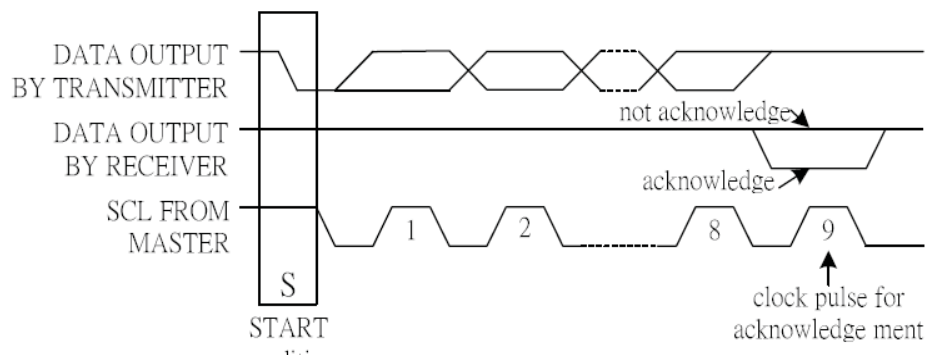

Fig .9.3 System configuration

## ➤ ACKNOWLEDGE

Each byte of eight bits is followed by an acknowledge bit. The acknowledge bit is a HIGH signal put on the bus by the transmitter during which time the master generates an extra acknowledge related clock pulse. A slave receiver which is addressed must generate an Acknowledge after the reception of each byte. A master receiver must also generate an Acknowledge after the reception of each byte that has been clocked out of the slave transmitter. The device that acknowledges must pull-down the SDA line during the acknowledge clock pulse, so that the SDA line is stable LOW during the HIGH period of the Acknowledge related clock pulse (set-up and hold times must be taken into consideration). A master receiver must signal an end-of-data to the transmitter by not generating an Acknowledge on the last byte that has been clocked out of the slave. In this event the transmitter must leave the data line HIGH to enable the master to generate a STOP condition. Acknowledgement on the I2C Interface is illustrated in Fig.9.4





## ➤ I2C Interface protocol

The RW1063 supports command, data write addressed slaves on the bus.

Before any data is transmitted on the IIC Interface, the device, which should respond, is addressed first.

Four 7-bit slave addresses (0111100, 0111101, 0111110 and 0111111) are reserved for the RW1063. The least significant bit of the slave address is set by connecting the input SA0 (DB0) and SA1 (DB1) to either logic 0 (VSS) or logic 1 (VDD).

The I2CInterface protocol is illustrated in Figure.9.5

The sequence is initiated with a START condition (S) from the I2CInterface master, which is followed by the slave address. All slaves with the corresponding address acknowledge in parallel, all the others will ignore the I2CInterface transfer. After acknowledgement, one or more command words follow which define the status of the addressed slaves.

A command word consists of a control byte, which defines Co and A0, plus a data byte.

The last control byte is tagged with a cleared most significant bit (i.e. the continuation bit Co). After a control byte with a cleared Co bit, only data bytes will follow. The state of the A0 bit defines whether the data byte is interpreted as a command or as RAM data. All addressed slaves on the bus also acknowledge the control and data bytes. After the last control byte, depending on the A0 bit setting; either a series of display data bytes or command data bytes may follow. If the A0 bit is set to logic 1, these display bytes are stored in the display RAM at the address specified by the data pointer. The data pointer is automatically updated and the data is directed to the intended RW1063 device. If the A0 bit of the last control byte is set to logic 0, these command bytes will be decoded and the setting of the device will be changed according to the received commands. Only the addressed slave makes the acknowledgement after each byte. At the end of the transmission the IIC interface-bus master issues a STOP condition (P). If no acknowledge is generated by the master after a byte, the driver stops transferring data to the master.

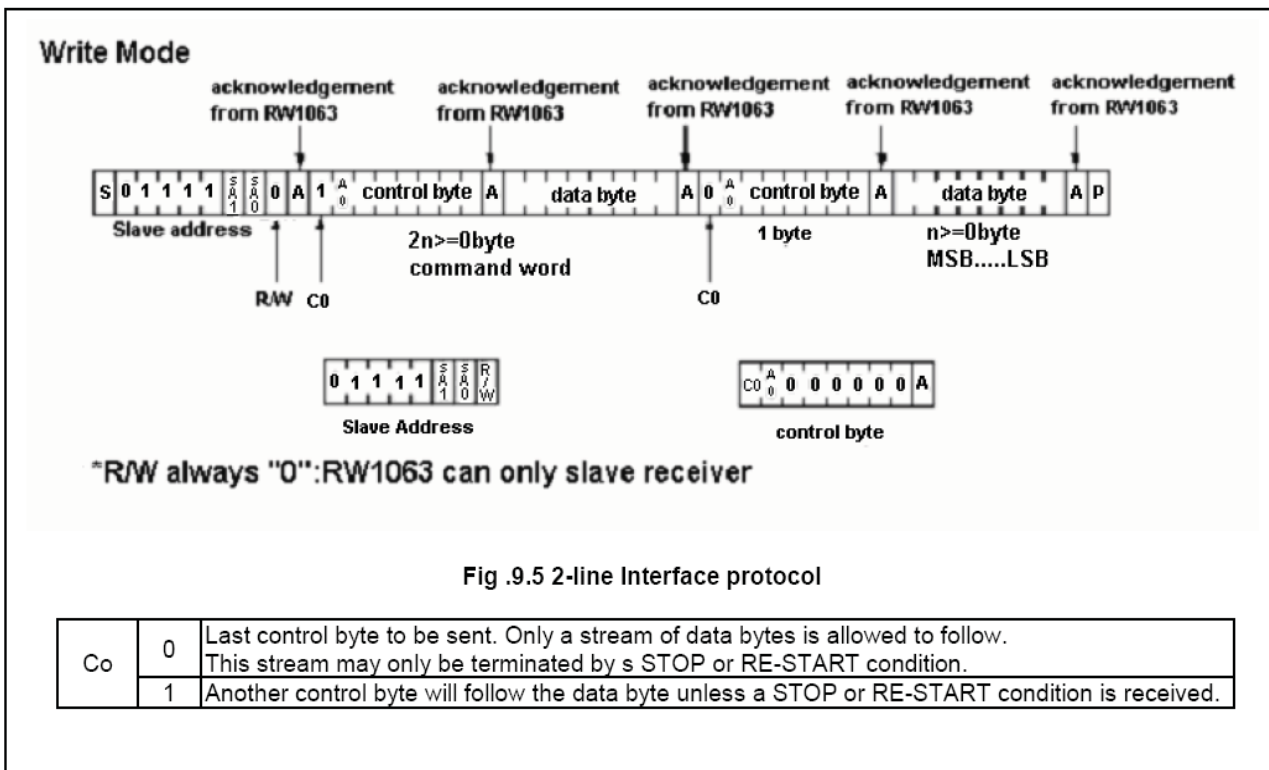

### Slave Address Option:

J8,J10 short,J7,J9open, SA1=0,SA0=0(default setting);

J8,J9 short,J7,J10open, SA1=0,SA0=1;

J7,J10 short,J8,J9open, SA1=1,SA0=0;

J7,J9 short,J8,J10open, SA1=1,SA0=1;

DB5(CSB)is connected to Vss by short J6.

# 14. Initializing of LCM

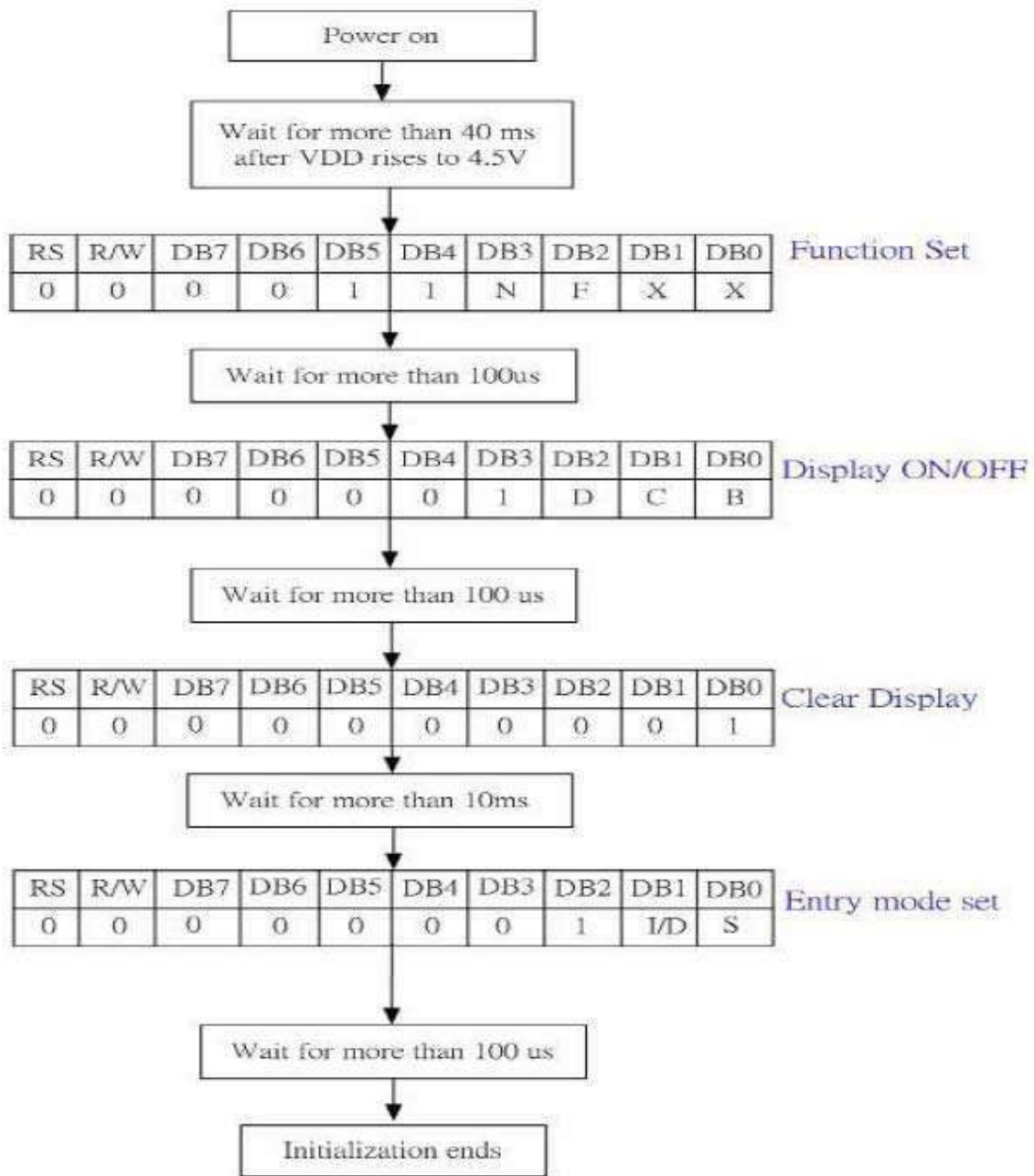

Initial Code:

```
void WriteData(BYTE byData)
```

```
{  
    I2C_Start();  
    I2C_Send(0x78);  
    I2C_Ack();  
    I2C_Send(0x40);  
    I2C_Ack();  
    I2C_Send(byData);  
    I2C_Ack();  
    I2C_Stop();  
}
```

```
void WriteInst(BYTE byInst)
```

```
{  
    I2C_Start();  
    I2C_Send(0x78);  
    I2C_Ack();  
    I2C_Send(0x00);  
    I2C_Ack();  
    I2C_Send(byInst);  
    I2C_Ack();  
    I2C_Stop();  
}
```

```
void InitRW1063(void)
```

```
{  
    WriteInst (0x38); //DL=1: 8 bits; N=1: 2 line; F=0: 5 x 8dots  
    WriteInst (0x0c); // D=1, display on; C=B=0; cursor off; blinking off;  
    WriteInst (0x06); // I/D=1: Increment by 1; S=0: No shift  
}
```

# 15. Quality Assurance

## Screen Cosmetic Criteria

Item	Defect	Judgment Criterion	Partition																				
1	Spots	<p>A) Clear</p> <table border="0"> <tr> <td><u>Size: d mm</u></td> <td><u>Acceptable Qty in active area</u></td> </tr> <tr> <td><math>d \leq 0.1</math></td> <td>Disregard</td> </tr> <tr> <td><math>0.1 &lt; d \leq 0.2</math></td> <td>6</td> </tr> <tr> <td><math>0.2 &lt; d \leq 0.3</math></td> <td>2</td> </tr> <tr> <td><math>0.3 &lt; d</math></td> <td>0</td> </tr> </table> <p>Note: Including pin holes and defective dots which must be within one pixel size.</p> <p>B) Unclear</p> <table border="0"> <tr> <td><u>Size: d mm</u></td> <td><u>Acceptable Qty in active area</u></td> </tr> <tr> <td><math>d \leq 0.2</math></td> <td>Disregard</td> </tr> <tr> <td><math>0.2 &lt; d \leq 0.5</math></td> <td>6</td> </tr> <tr> <td><math>0.5 &lt; d \leq 0.7</math></td> <td>2</td> </tr> <tr> <td><math>0.7 &lt; d</math></td> <td>0</td> </tr> </table>	<u>Size: d mm</u>	<u>Acceptable Qty in active area</u>	$d \leq 0.1$	Disregard	$0.1 < d \leq 0.2$	6	$0.2 < d \leq 0.3$	2	$0.3 < d$	0	<u>Size: d mm</u>	<u>Acceptable Qty in active area</u>	$d \leq 0.2$	Disregard	$0.2 < d \leq 0.5$	6	$0.5 < d \leq 0.7$	2	$0.7 < d$	0	Minor
<u>Size: d mm</u>	<u>Acceptable Qty in active area</u>																						
$d \leq 0.1$	Disregard																						
$0.1 < d \leq 0.2$	6																						
$0.2 < d \leq 0.3$	2																						
$0.3 < d$	0																						
<u>Size: d mm</u>	<u>Acceptable Qty in active area</u>																						
$d \leq 0.2$	Disregard																						
$0.2 < d \leq 0.5$	6																						
$0.5 < d \leq 0.7$	2																						
$0.7 < d$	0																						
2	Bubbles in Polarizer	<table border="0"> <tr> <td><u>Size: d mm</u></td> <td><u>Acceptable Qty in active area</u></td> </tr> <tr> <td><math>d \leq 0.3</math></td> <td>Disregard</td> </tr> <tr> <td><math>0.3 &lt; d \leq 1.0</math></td> <td>3</td> </tr> <tr> <td><math>1.0 &lt; d \leq 1.5</math></td> <td>1</td> </tr> <tr> <td><math>1.5 &lt; d</math></td> <td>0</td> </tr> </table>	<u>Size: d mm</u>	<u>Acceptable Qty in active area</u>	$d \leq 0.3$	Disregard	$0.3 < d \leq 1.0$	3	$1.0 < d \leq 1.5$	1	$1.5 < d$	0	Minor										
<u>Size: d mm</u>	<u>Acceptable Qty in active area</u>																						
$d \leq 0.3$	Disregard																						
$0.3 < d \leq 1.0$	3																						
$1.0 < d \leq 1.5$	1																						
$1.5 < d$	0																						
3	Scratch	In accordance with spots cosmetic criteria. When the light reflects on the panel surface, the scratches are not to be remarkable.	Minor																				
4	Allowable Density	Above defects should be separated more than 30mm each other.	Minor																				
5	Coloration	Not to be noticeable coloration in the viewing area of the LCD panels. Back-light type should be judged with back-light on state only.	Minor																				

# 16. Reliability

## Content of Reliability Test

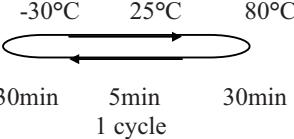
Environmental Test			
Test Item	Content of Test	Test Condition	Applicable Standard
High Temperature storage	Endurance test applying the high storage temperature for a long time.	80°C 96hrs	—
Low Temperature storage	Endurance test applying the high storage temperature for a long time.	-30°C 96hrs	—
High Temperature Operation	Endurance test applying the electric stress (Voltage & Current) and the thermal stress to the element for a long time.	70°C 96hrs	—
Low Temperature Operation	Endurance test applying the electric stress under low temperature for a long time.	-20°C 96hrs	—
High Temperature/ Humidity Storage	Endurance test applying the high temperature and high humidity storage for a long time.	80°C,90%RH 96hrs	—
High Temperature/ Humidity Operation	Endurance test applying the electric stress (Voltage & Current) and temperature / humidity stress to the element for a long time.	70°C,90%RH 96hrs	—
Temperature Cycle	Endurance test applying the low and high temperature cycle.  <p style="text-align: center;">-30°C    25°C    80°C</p> <p style="text-align: center;">30min    5min    30min</p> <p style="text-align: center;">1 cycle</p>	-30°C → 80°C 10 cycles	—
Mechanical Test			
Vibration test	Endurance test applying the vibration during transportation and using.	10~22Hz→1.5mmp-p 22~500Hz→1.5G Total 0.5hrs	—
Shock test	Constructional and mechanical endurance test applying the shock during transportation.	50G Half sign wave 11 msdc 3 times of each direction	—

\*\*\*Supply voltage for logic system=5V. Supply voltage for LCD system =Operating voltage at 25°C