



EVQ8623-D-00A

16V, 6A, High-Efficiency, Synchronous, Step-Down Converter Evaluation Board

DESCRIPTION

The EVQ8623-D-00A is an evaluation board for the MPQ8623, a high-efficiency, monolithic, synchronous, step-down converter.

The EV board can deliver 6A of continuous load current over a wide operating input range. High efficiency can be achieved over a wide output current load range.

The MPQ8623 adopts an internally compensated constant-on-time (COT) control mode that provides fast transient response and eases loop stabilization.

This EV board can be turned on or off via a remote on/off input (EN) that is referenced to ground. This input is compatible with popular logic devices.

ELECTRICAL SPECIFICATION

Parameter	Symbol	Value	Units
Input voltage	V_{IN}	8-16	V
Output voltage	V_{OUT}	1.8	V
Output current	I_{OUT}	6	A

FEATURES

- Wide Input Voltage Range
 - 2.85V to 16V with External 3.3V VCC Bias
 - 4V to 16V with Internal VCC Bias or External 3.3V Bias
- Programmable Accurate Current Limit Level
- 6A Output Current
- Low $R_{DS(ON)}$ Integrated Power MOSFETs
- Proprietary Switching Loss Reduction Technique
- Adaptive COT for Ultra-Fast Transient Response
- Stable with Zero-ESR Output Capacitor
 - 0.5% Reference Voltage Over 0°C to +70°C Junction Temperature Range
 - 1% Reference Voltage Over -40°C to +125°C Junction Temperature Range
- Selectable Pulse-Skip or Forced CCM Operation
- Excellent Load Regulation
- Output Voltage Tracking
- Output Voltage Discharge
- PGOOD Active Clamped Low Level during Power Failure
- Programmable Soft Start Time from 1.5ms
- Pre-Bias Start-Up
- Selectable Switching Frequency of 600kHz, 1100kHz, and 2000kHz Latch-Off for OCP, OVP, UVP, UVLO, and Thermal Shutdown
- Output Adjustable from 0.9V to 90%* V_{in} , Up to 6V Max
- Available in a QFN (2mmx3mm) Package

APPLICATIONS

- Telecom and Networking Systems
- Server, Cloud Computing, Storage
- Base Stations
- General Purpose Point-of-Load (PoL)
- 12V Distribution Power Systems
- High-End TV
- Game Consoles and Graphic Cards

All MPS parts are lead-free, halogen-free, and adhere to the RoHS directive. For MPS green status, please visit the MPS website under Quality Assurance. "MPS", the MPS logo, and "Simple, Easy Solutions" are trademarks of Monolithic Power Systems, Inc. or its subsidiaries.

EVQ8623-D-00A EVALUATION BOARD



(L x W) 81mm x 78mm)

Board Number	MPS IC Number
EVQ8623-D-00A	MPQ8623GD

EVALUATION BOARD SCHEMATIC

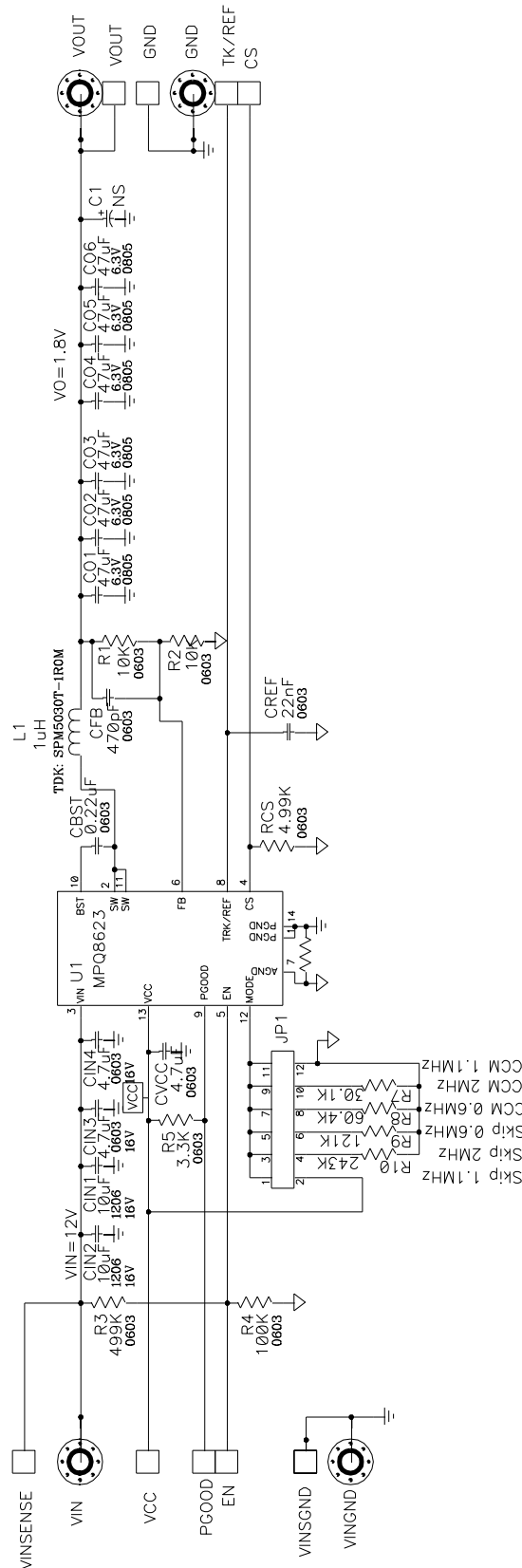

EVQ8623-D-00A BILL OF MATERIALS

Qty	Ref	Value	Description	Package	Manufacturer	Part Number
0	C1	NS		Pos-cap/D2		
1	CBST	0.22 μ F	CAP CER 0.22 μ F 25V 10% X7R 0603	CAP0603	Generic	
1	CFB	470pF	CAP, 50V, 10%, X7R	CAP0603	Generic	
2	CIN1, CIN2	10 μ F/25V	Capacitor, 25V, X7R, 10%	CAP1206	Generic	
2	CIN3, CIN4	4.7 μ F/25V	CAP CER 4.7 μ F 25V 10% X6S 0603	CAP0603	Generic	
6	CO1, CO2, CO3, CO4, CO5, CO6	47 μ F	CAP, 6.3V, X5R, 20%	CAP0805	Murata or Generic	GRM21BR60J476ME15L
1	CREF	22nF	CAP CER 22nF 25V 10% X7R 0603	CAP0603	Generic	
1	CVCC	4.7 μ F	CAP CER 4.7 μ F 6.3v 10% X7R 0603	CAP0603	Generic	
1	L1	1 μ H	Inductor	7x7mm	TDK or Others	SPM5030T-1R0M
2	R1, R2	10k	Film Res., 1%	0603	Generic	
1	R3	499k	Film Res., 1%	0603	Generic	
1	R4	100k	Film Res., 1%	0603	Generic	
1	R5	3.3k	Film Res., 1%	0603	Generic	
1	R7	30.1k	Film Res., 1%	0603	Generic	
1	R8	60.4k	Film Res., 1%	0603	Generic	
1	R9	121k	Film Res., 1%	0603	Generic	
1	R10	243k	Film Res., 1%	0603	Generic	
1	RCS	4.99k	Film Res., 1%	0603	Generic	
1	U1	MQ8623GD	16V/6A Step Down Convert	QFN-14 (2x3mm)	MPS	MPQ8623GD

EVB TEST RESULTS

Performance waveforms are tested on the EVQ8623-D-00A evaluation board.

$V_{IN} = 12V$, $V_{OUT} = 1.8V$, $L = 1\mu H$, $T_A = +25^\circ C$, unless otherwise noted.

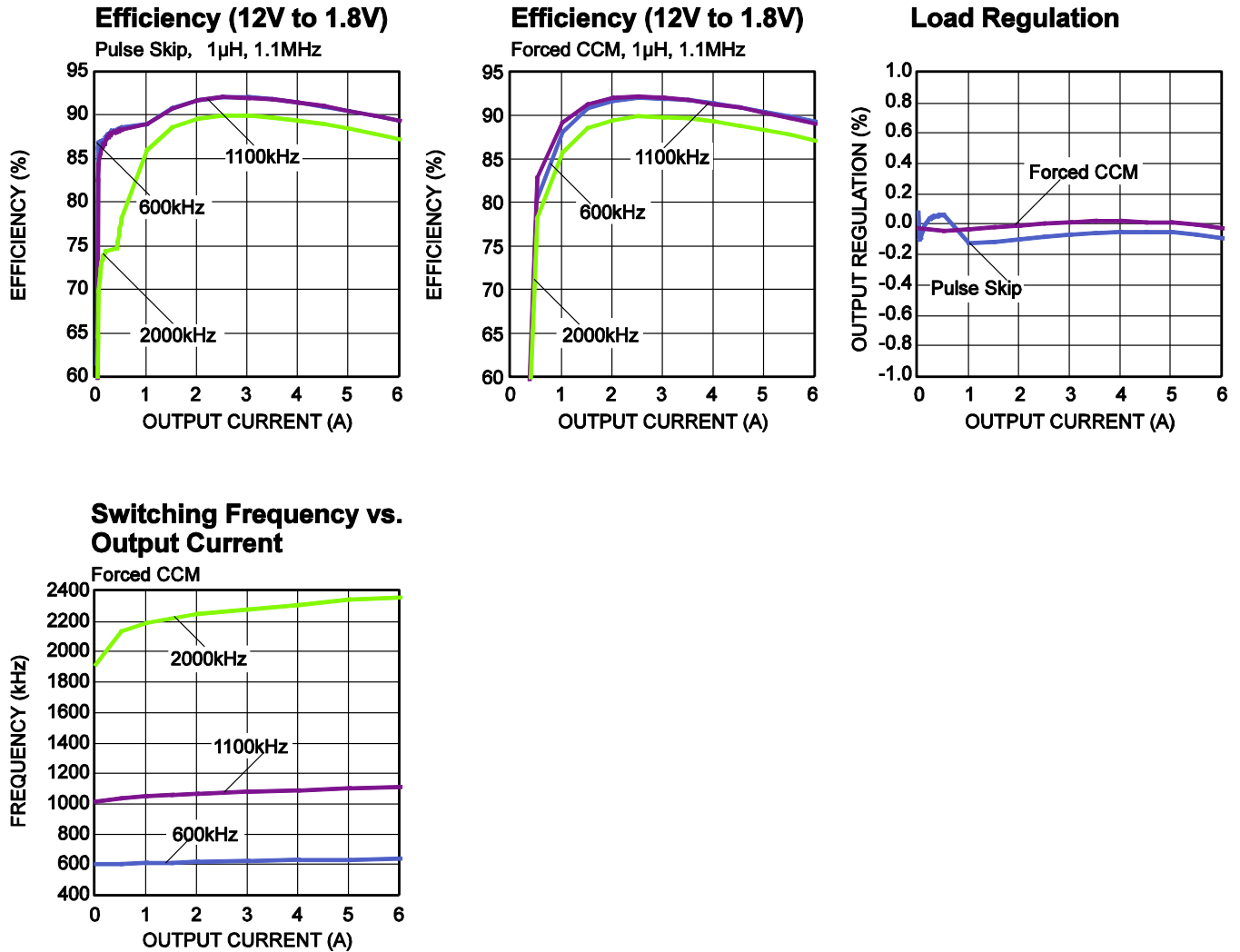

EVB TEST RESULTS (continued)

Performance waveforms are tested on the EVQ8623-D-00A evaluation board.

 $V_{IN} = 12V$, $V_{OUT} = 1.8V$, $L = 1\mu H$, $T_A = +25^\circ C$, unless otherwise noted.

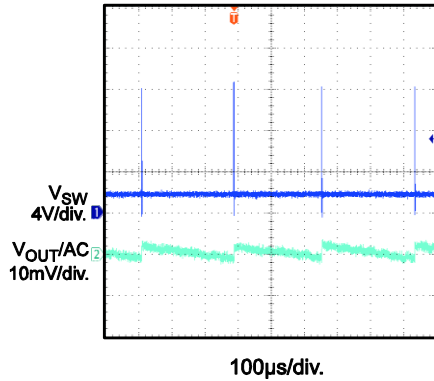
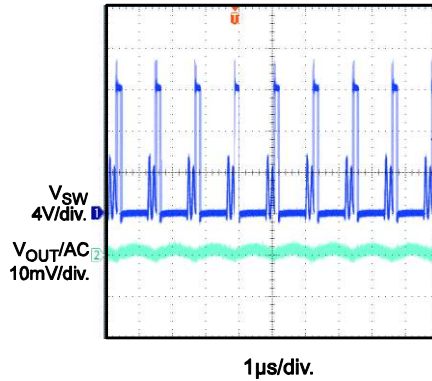
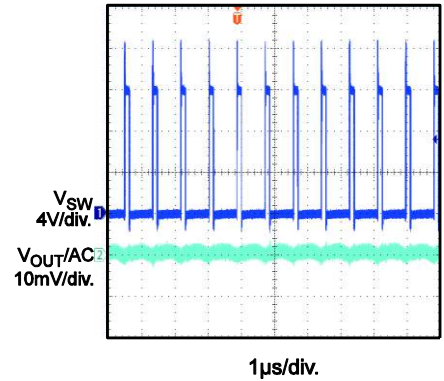
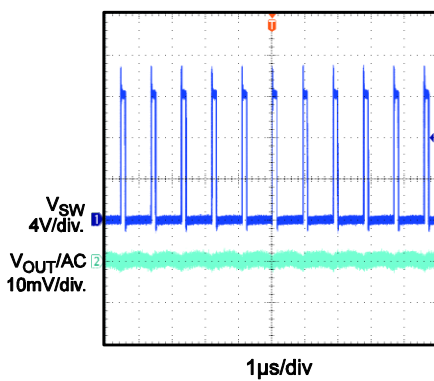
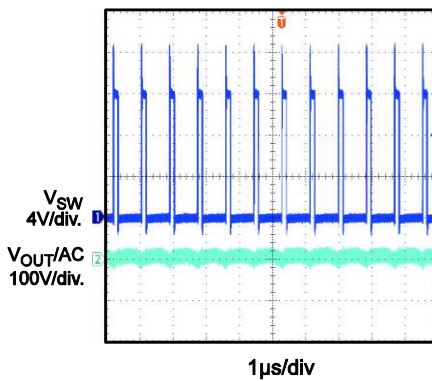
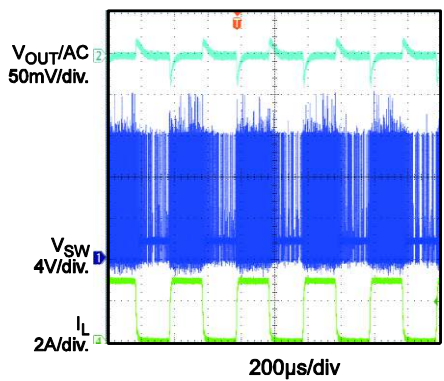
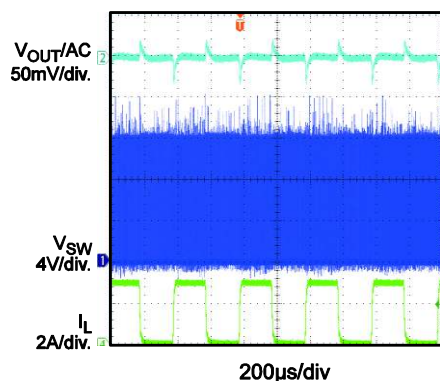
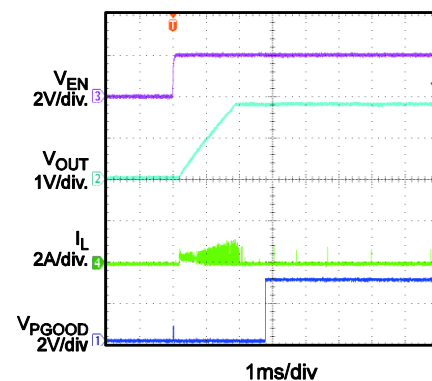
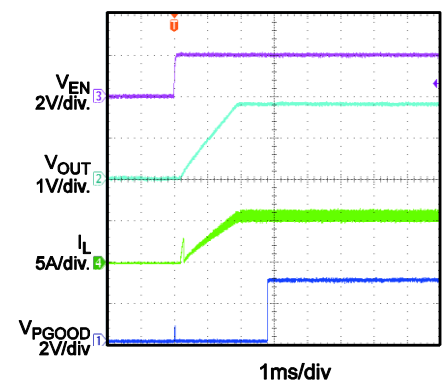
Steady State
 $I_{OUT} = 0A$, Pulse Skip

Steady State
 $I_{OUT} = 0.5A$, Pulse Skip

Steady State
 $I_{OUT} = 6A$, Pulse Skip

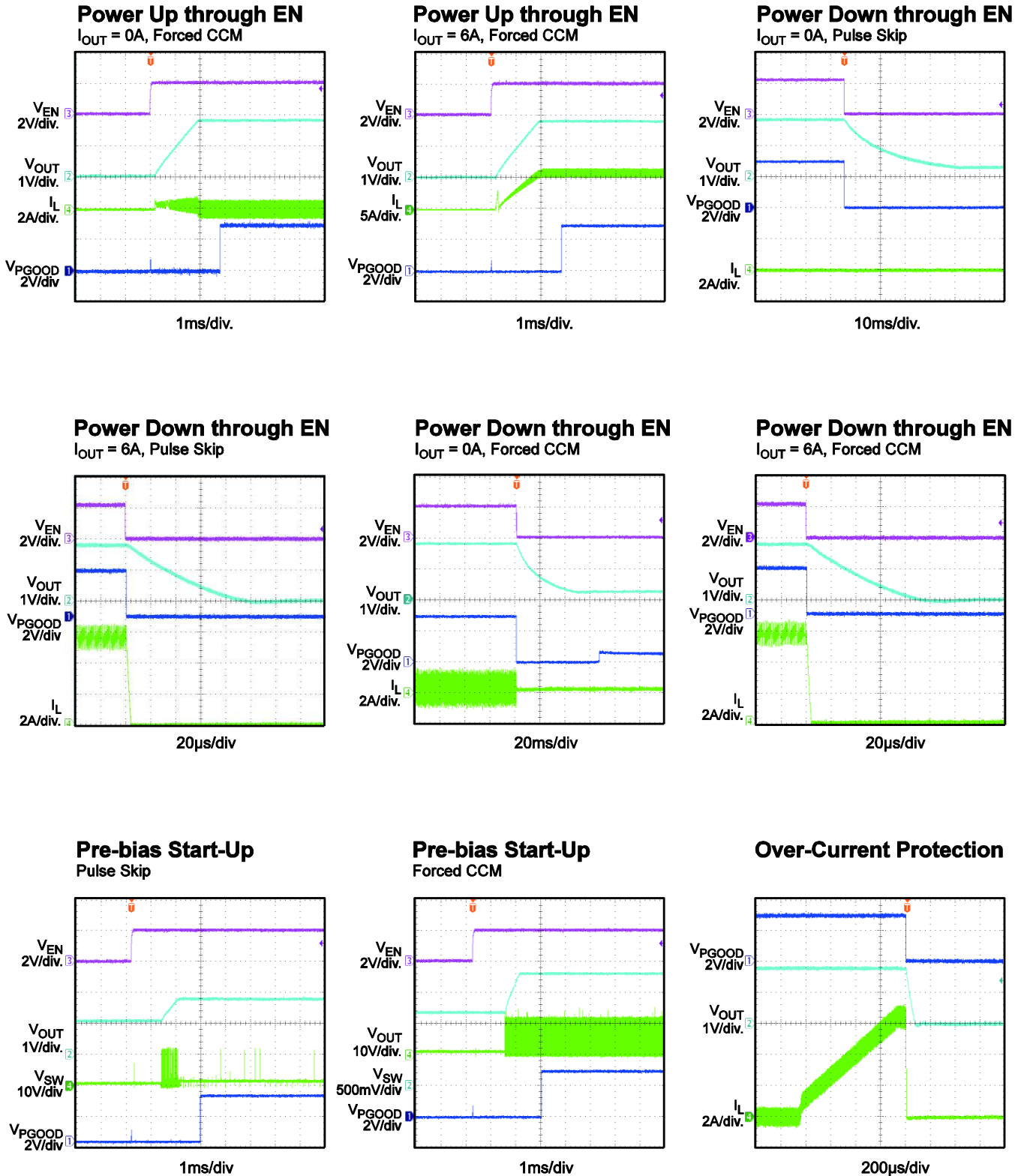
Steady State
 $I_{OUT} = 0A$, Forced CCM

Steady State
 $I_{OUT} = 6A$, Forced CCM

Load Transient
 $I_{OUT} = 0A-3A$, Pulse Skip

Load Transient
 $I_{OUT} = 0A-3A$, Forced CCM

Power Up through EN
 $I_{OUT} = 0A$, Pulse Skip

Power Up through EN
 $I_{OUT} = 6A$, Pulse Skip

EVB TEST RESULTS (continued)

Performance waveforms are tested on the EVQ8623-D-00A evaluation board.

 $V_{IN} = 12V$, $V_{OUT} = 1.8V$, $L = 1\mu H$, $T_A = +25^\circ C$, unless otherwise noted.

EVB TEST RESULTS *(continued)*

Performance waveforms are tested on the EVQ8623-D-00A evaluation board.

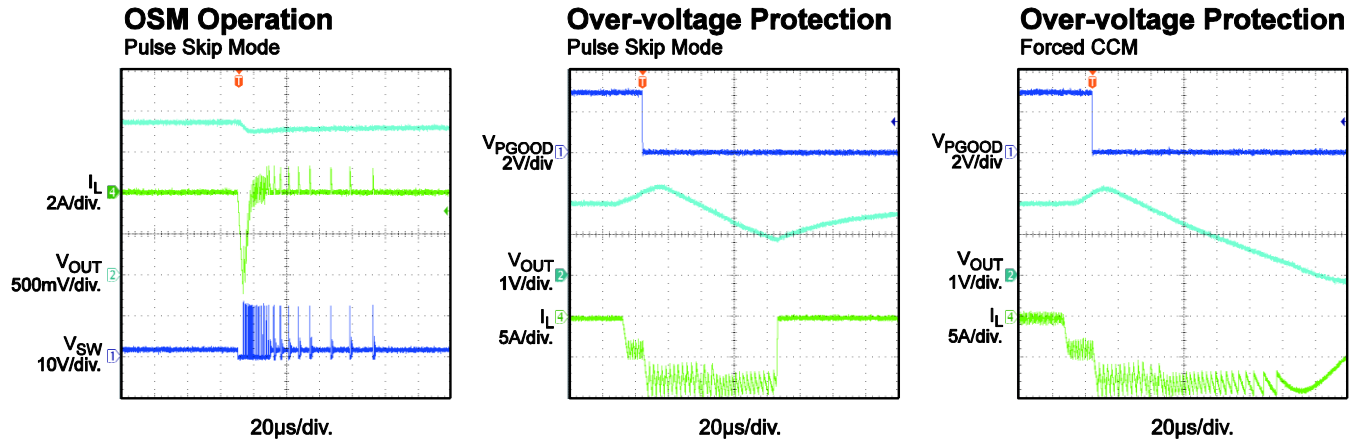
 $V_{IN} = 12V$, $V_{OUT} = 1.8V$, $L = 1\mu H$, $T_A = +25^\circ C$, unless otherwise noted.

PRINTED CIRCUIT BOARD (PCB) LAYOUT

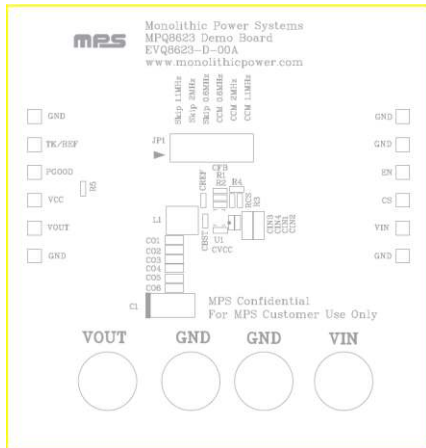

Figure 1: Top Silk Layer

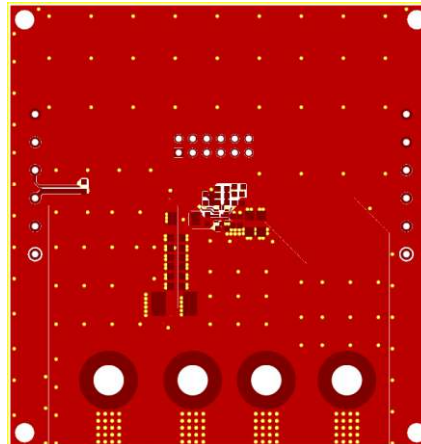

Figure 2: Top Layer

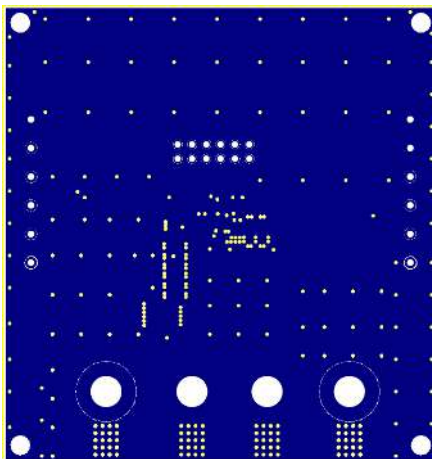

Figure 3: Inner Layer 1

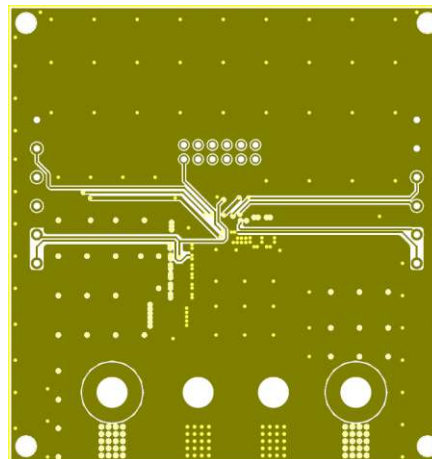

Figure 4: Inner Layer 2

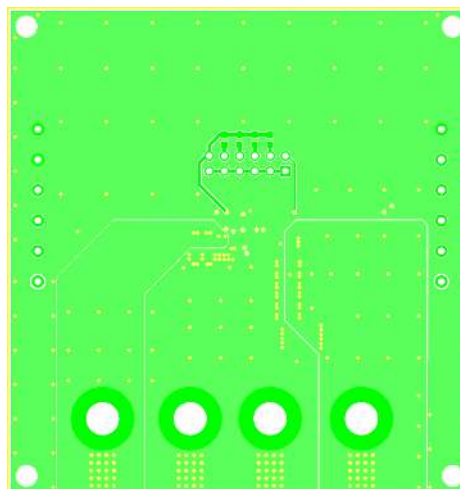

Figure 5: Bottom Layer

QUICK START GUIDE

The input voltage of the EV board can range from 8V to 16V. The minimum 8V input voltage is limited by the EN signal, which is derived from VIN through a resistor divider (R3 and R4). A lower input voltage (as low as 2.85V with external 3.3V VCC bias) can be set by fine-tuning the resistor divider values or by over-driving EN with an external control signal. The steps below outline the procedure for turning on the EV board.

1. Connect the positive and negative terminals of the load to the VOUT and GND pins, respectively.
2. Preset the power supply output voltage between 8V and 16V, and then turn off the power supply.
3. Connect the positive and negative terminals of the power supply output to the VIN and GND pins, respectively. Ensure that the power supply has a current limit high enough to supply the power.
4. Turn the power supply on. The EVQ8623-D-00A will start up automatically.
5. To use the enable function, apply a digital input to the EN pin. Drive EN above 1.5V to turn on the regulator. Drive EN below 0.8V to turn off the regulator.
6. Use R1 and R2 to set the output voltage with $V_{FB} = 0.9V$. Refer to the Application Information section in the device datasheet to select the proper values for R1, R2, the inductor, and the output capacitor when the output voltage is changed.
7. The JP1 jumper can be used to select the operating frequency (600kHz, 1100kHz, or 2000kHz) and light-load operation mode (pulse-skip mode or CCM).

NOTICE: The information in this document is subject to change without notice. Please contact MPS for current specifications. Users should warrant and guarantee that third party Intellectual Property rights are not infringed upon when integrating MPS products into any application. MPS will not assume any legal responsibility for any said applications.