

断面図 (参考)

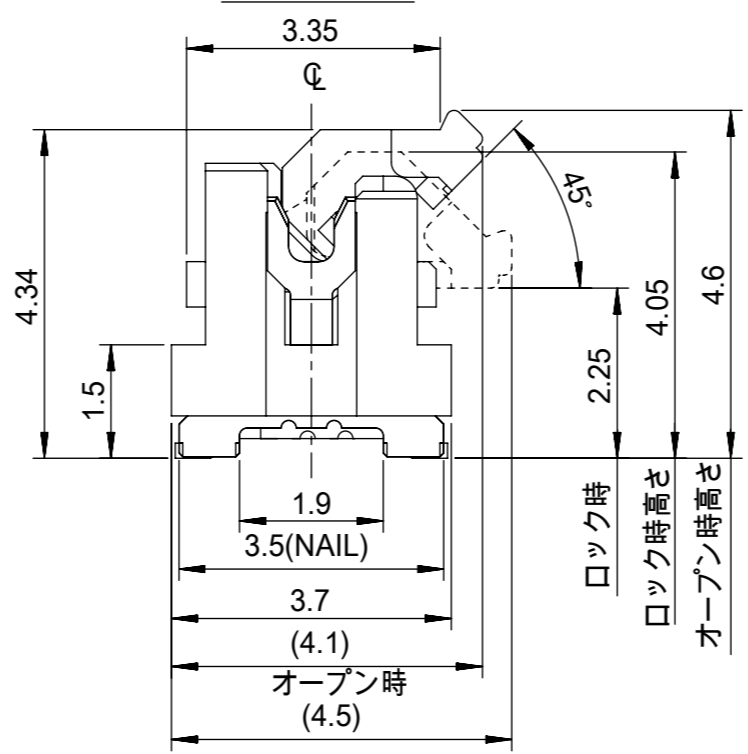

注記 NOTES

1. 使用材料 MATERIAL
 ハウジング : 液晶ポリマー ガラス充填, UL94V-0(白)
 HOUSING LIQUID CRYSTAL POLYMER
 GLASS FILLED, UL94V-0 (WHITE)
 アクチュエータ : ポリアミド 9T, ガラス充填, UL94V-0(茶)
 ACTUATOR POLYAMIDE 9T, GLASS FILLED,
 UL94V-0 (BROWN)
 ターミナル : 銅合金(t=0.15)
 TERMINAL COPPER ALLOY
 金具 : 銅合金(t=0.2)
 FITTING NAIL COPPER ALLOY
 2. めっき仕様 PLATING
 ターミナル TERMINAL
 コンタクト部 : 部分金めっき(0.1μm以上)
 テール部 : 部分金めっき
 下地 : ニッケルめっき(1.0μm以上)
 CONTACT AREA : SEPARATED GOLD PLATING
 (0.1 MICROMETER MINIMUM)
 SOLDER TAIL AREA : SEPARATED GOLD PLATING
 UNDERPLATE : NICKEL OVERALL
 金具 FITTING NAIL
 ニッケル下地 錫めっき
 錫めっき(1.0μm以上)
 ニッケルめっき(1.0μm以上)
 TIN(Sn) OVER NICKEL(Ni) PLATING.
 TIN PLATING (1.0 MICROMETER MINIMUM)
 NICKEL PLATING (1.0 MICROMETER MINIMUM)
 3. テールと金具を併せた平坦度は 0.1ミリメートル以下(リフロー前)
 TAILS AND NAILS COPLANARITY
 TO BE 0.1 MAX. (BEFORE REFLOW)
 4. ELV及びRoHS適合品
 ELV AND RoHS COMPLIANT
- △ R0.3は、FPC導体部にかからないこと。
 R0.3 MUST NOT BE OVERLAPPED
 TO PATTERN OF FPC.

8	35.7	37.1	37.4	34.5	37.8	501951-7010	70
	30.7	32.1	32.4	29.5	32.8	501951-6010	60
	25.7	27.1	27.4	24.5	27.8	501951-5010	50
	23.2	24.6	24.9	22.0	25.3	501951-4510	45
	20.7	22.1	22.4	19.5	22.8	501951-4010	40
	16.7	18.1	18.4	15.5	18.8	501951-3210	32
	15.7	17.1	17.4	14.5	17.8	501951-3010	30
	12.7	14.1	14.4	11.5	14.8	501951-2410	24
	11.7	13.1	13.4	10.5	13.8	501951-2210	22
10.7	12.1	12.4	9.5	12.8	501951-2010	20	
F	E	D	C	B	A	EMBOSSED PACKAGE オーダー番号 ORDER NO.	CIRCUITS

CONNECTOR SERIES NO. 501951-**19

GENERAL TOLERANCES (UNLESS SPECIFIED)	
0.25 UNDER	±0.03
0.25 OVER 0.5 UNDER	±0.05
0.5 OVER 1.0 UNDER	±0.1
1.0 OVER 10 UNDER	±0.2
10 OVER 30 UNDER	±0.25
30 OVER	±0.3
ANGULAR	±1°

THIS DRAWING CONTAINS INFORMATION THAT IS PROPRIETARY TO MOLEX ELECTRONIC TECHNOLOGIES, LLC AND SHOULD NOT BE USED WITHOUT WRITTEN PERMISSION

DIMENSION UNITS: mm SCALE: 10:1

CURRENT REV DESC: REVISED

molex

0.5 FPC CONN. HSG ASSY
EASY ON / STRAIGHT (GOLD)

PRODUCT CUSTOMER DRAWING

EC NO: 637653
 DRWN: TNAKAGAWA01 2020/05/15
 CHK'D: HSHIMOYAMA 2020/05/15
 APPR: SHOSHIKAWA 2020/05/15

INITIAL REVISION:
 DRWN: TRSUZUKI 2006/08/31
 APPR: HHIRATA 2006/09/05

DOCUMENT NUMBER: SD-501951-003
 DOC TYPE: PSD
 DOC PART: 001
 REVISION: G

DRAFT WHERE APPLICABLE MUST REMAIN WITHIN DIMENSIONS

THIRD ANGLE PROJECTION

DRAWING: A3-SIZE
 SERIES: 501951
 MATERIAL NUMBER: SEE TABLE
 CUSTOMER: GENERAL MARKET
 SHEET NUMBER: 1 OF 2

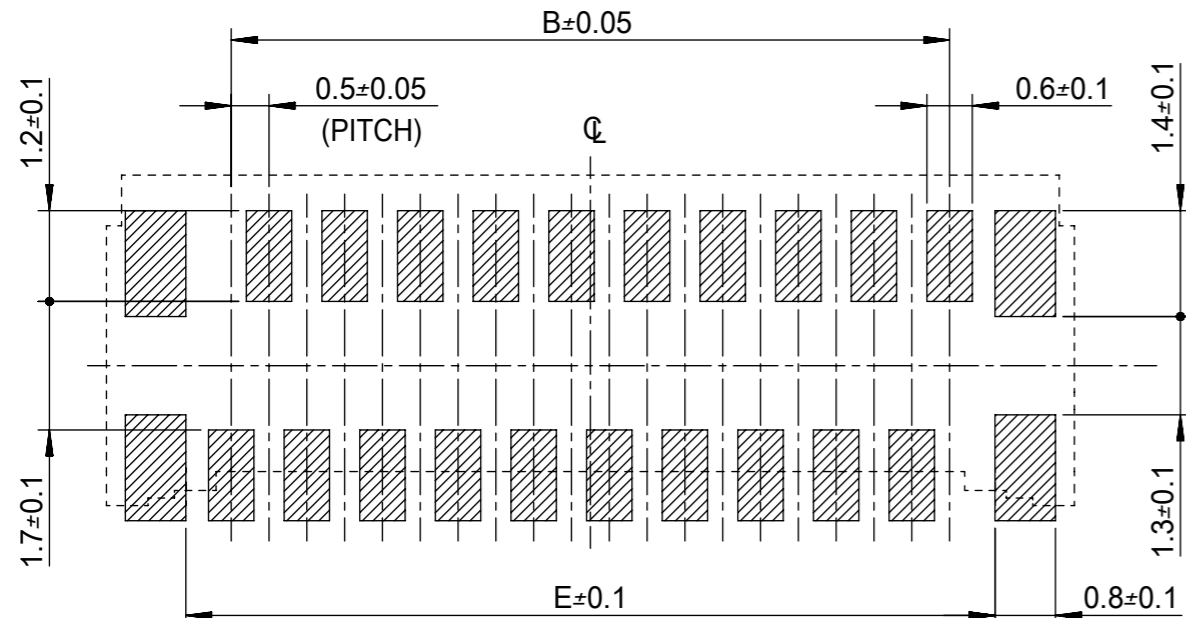

参考基板レイアウト (マウント面)
P.C.BOARD PATTERN DIMENSION(REF.)
(MOUNT AREA)

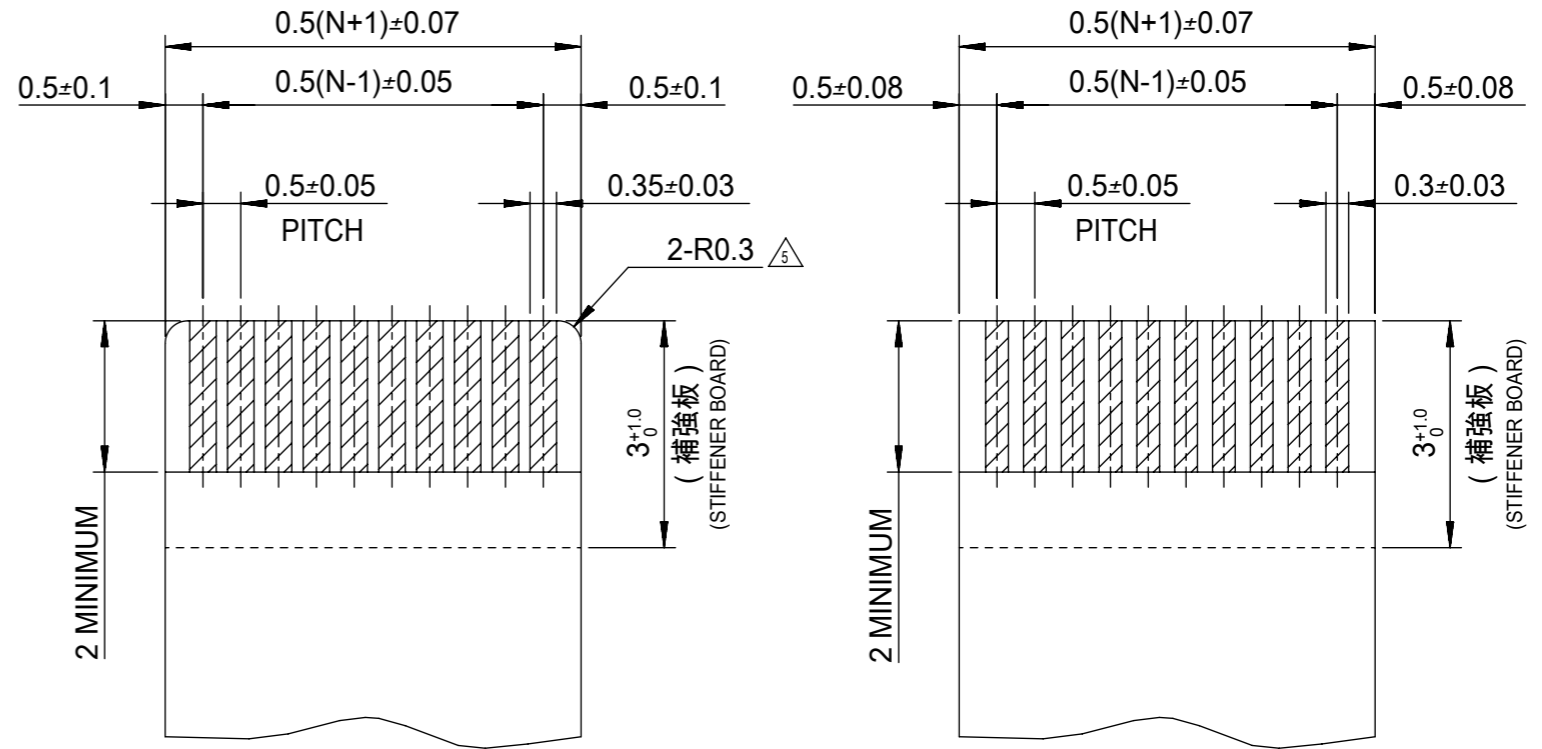

適合FPC推奨寸法 N:極数 N:CIRCUITS
APPLICABLE FPC RECOMMENDED DIMENSION
(仕上がり厚さ: 0.3±0.05)
(THICKNESS: 0.3±0.05)

適合FFC推奨寸法 N:極数 N:CIRCUITS
APPLICABLE FFC RECOMMENDED DIMENSION
(仕上がり厚さ: 0.3±0.05)
(THICKNESS: 0.3±0.05)

FPCについて ABOUT FPC

補強フィルム材質はポリイミドを推奨します。ベースフィルムは25μmを推奨します。
接着剤は熱硬化接着剤を推奨します。
尚、接着剤の接点部への付着は導通不良の原因になりますので、染み出しが無い様お願い致します。

RECOMMENDED MATERIAL/THICKNESS.
RECOMMENDED STIFFENER MATERIAL: POLYIMIDE
RECOMMENDED BASE FILM THICKNESS: 25 MICROMETER
RECOMMENDED ADHESIVE: THERMOSETTING ADHESIVE

NOTE: PLEASE PUT APPROPRIATE AMOUNT OF ADHESIVE ON ADHEREND BECAUSE THERE IS A POSSIBILITY THAT THE EXTRA ADHESIVE CAUSES THE DEFECT IN ELECTRICAL CONTINUITY.
THERE IS A POSSIBILITY THAT THE PRESCRIPT TEMPERATURE OF FFC IS SET TO SINGLE IT.

FPC/FFCについて ABOUT FPC/FFC

打ち抜き方向は導体側から補強板側を推奨します。
導体部については軟箔銅35μmまたは50μmを推奨します。
FFCに規定された定格温度がFFC単体前提である場合が御座います。
コネクタと組み合わせての実使用において、接着層が劣化するなどの信頼性を満足できないケースを回避するため、実機での評価/確認をお願い致します。

RECOMMENDED PUNCHING DIRECTION: FROM CONDUCTOR SIDE TO STIFFENER SIDE
RECOMMENDED CONDUCTOR SPEC: SOFT COPPER FOIL
RECOMMENDED CONDUCTOR THICKNESS: 35 MICROMETER OR 50 MICROMETER
NOTE: WHEN ACTUALLY USING IT WITH CONNECTOR, PLEASE DO THE EVALUATION AND THE CONFIRMATION WITH AN ACTUAL EQUIPMENT TO EVADE THE CASE WHERE RELIABILITY CANNOT BE FILLED (THE ADHESIVE LINE OF FFC IS DETERIORATED ETC.)

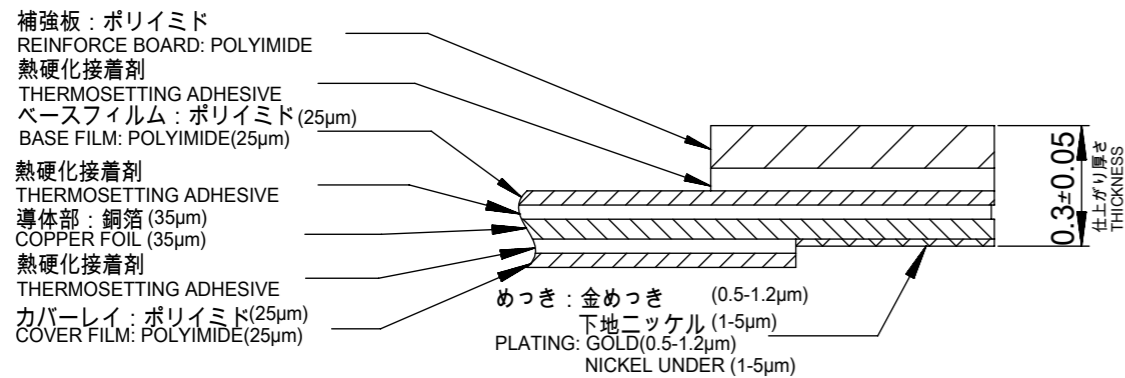

FPC構成推奨仕様
STRUCTURE OF FPC

GENERAL TOLERANCES (UNLESS SPECIFIED)	
0.25 UNDER	±0.03
0.25 OVER 0.5 UNDER	±0.05
0.5 OVER 1.0 UNDER	±0.1
1.0 OVER 10 UNDER	±0.2
10 OVER 30 UNDER	±0.25
30 OVER	±0.3
ANGULAR	±1°

THIS DRAWING CONTAINS INFORMATION THAT IS PROPRIETARY TO MOLEX ELECTRONIC TECHNOLOGIES, LLC AND SHOULD NOT BE USED WITHOUT WRITTEN PERMISSION

DIMENSION UNITS	SCALE	CURRENT REV DESC: REVISED	
mm	10:1		
GENERAL TOLERANCES (UNLESS SPECIFIED)		EC NO: 637653	
ANGULAR TOL	± 1.0°	DRWN: TNAKAGAWA01	2020/05/15
4 PLACES	± 0.2	CHK'D: HSHIMOYAMA	2020/05/15
3 PLACES	± 0.25	APPR: SHOSHIKAWA	2020/05/15
2 PLACES	± 0.3	INITIAL REVISION:	
1 PLACE	± 0.05	DRWN: TRSUZUKI	2006/08/31
0 PLACES	±	APPR: HHIRATA	2006/09/05
DRAFT WHERE APPLICABLE MUST REMAIN WITHIN DIMENSIONS		THIRD ANGLE PROJECTION	DRAWING
		①	A3-SIZE
		SERIES	501951
		MATERIAL NUMBER	SEE SHEET 1
		CUSTOMER	GENERAL MARKET
		DOCUMENT NUMBER	SD-501951-003
		DOC TYPE	PSD
		DOC PART	001
		REVISION	G
		SHEET NUMBER	
		2 OF 2	

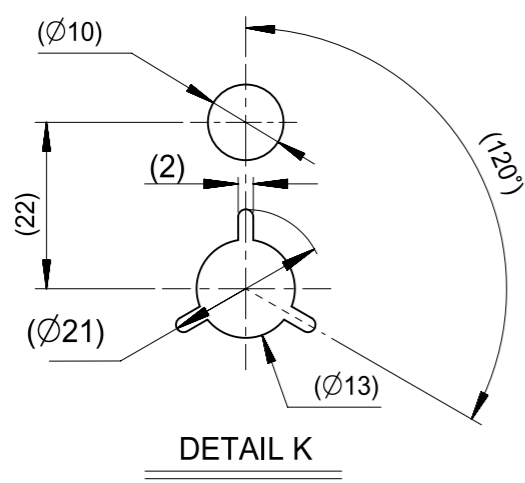
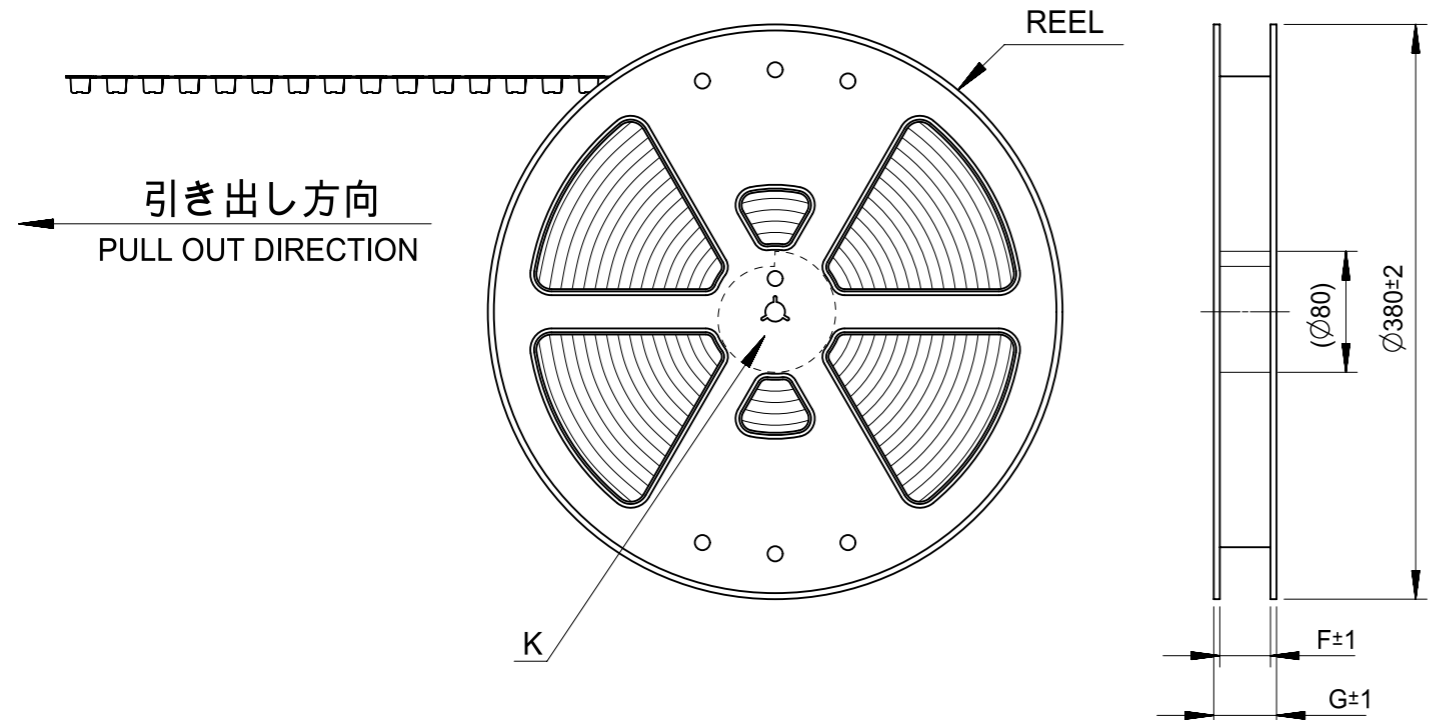

NOTES

- 製品詳細寸法については図面 SD-501951-003を参照下さい。
FOR DIMENSIONS OF PRODUCT, REFER TO SD-501951-003.
- 梱包数量：2000個/リール
NUMBER OF CONNECTORS：2000PIECES/REEL
- リードテープ長さ
LEAD TAPE LENGTH

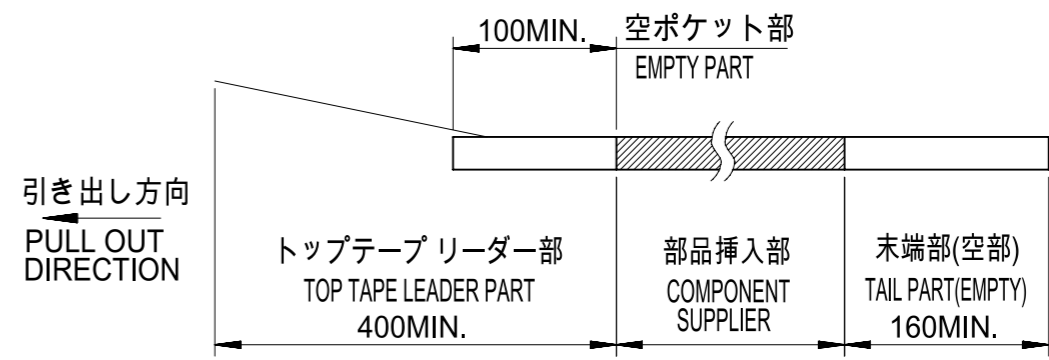

- トップテープの剥離強度については、IEC60286-3に準拠
TOP TAPE PEEL FORCE IS DEFINED BY IEC 60286-3.
- 材料 MATERIAL
キャリアテープ：ポリスチレン
CARRIER TAPE：POLYSTYRENE
トップテープ：ポリエチレンテレフタレート、ポリエチレン
TOP TAPE：POLYETHYLENE TEREPHTHALATE, POLYETHYLENE
リール：ポリスチレン<リサイクル材を含む>
REEL：POLYSTYRENE<RECYCLE MATERIAL CONTAINED>
- ELV及びRoHS適合品 ELV AND RoHS COMPLIANT

THIS DRAWING CONTAINS INFORMATION THAT IS PROPRIETARY TO MOLEX ELECTRONIC TECHNOLOGIES, LLC AND SHOULD NOT BE USED WITHOUT WRITTEN PERMISSION									
DIMENSION UNITS		SCALE		CURRENT REV DESC:				molex	
mm		10:1							
GENERAL TOLERANCES (UNLESS SPECIFIED)				EC NO: 601584				0.5 FPC CONN. HSG ASSY	
ANGULAR TOL ± 1.0 °				DRWN: SKAWAKAMI 2018/09/21				E/O STRAIGHT EMBSTP PKG (GOLD)	
4 PLACES ± 0.05				CHK'D: TRSUZUKI 2018/09/25					
3 PLACES ± 0.1				APPR: RTAKEUCHI 2018/12/25				PRODUCT CUSTOMER DRAWING	
2 PLACES ± 0.2				INITIAL REVISION:				DOCUMENT NUMBER	
1 PLACE ± 0.25				DRWN: TRSUZUKI 2006/08/31				SD-501951-004	
0 PLACES ± 0.3				APPR: HHIRATA 2006/09/05				PSD 001 F	
DRAFT WHERE APPLICABLE MUST REMAIN WITHIN DIMENSIONS		THIRD ANGLE PROJECTION		DRAWING		SERIES		MATERIAL NUMBER	
				A3-SIZE		501951		CUSTOMER	
								GENERAL MARKET	
								SHEET NUMBER	
								1 OF 2	

引き出し方向
PULL OUT DIRECTION

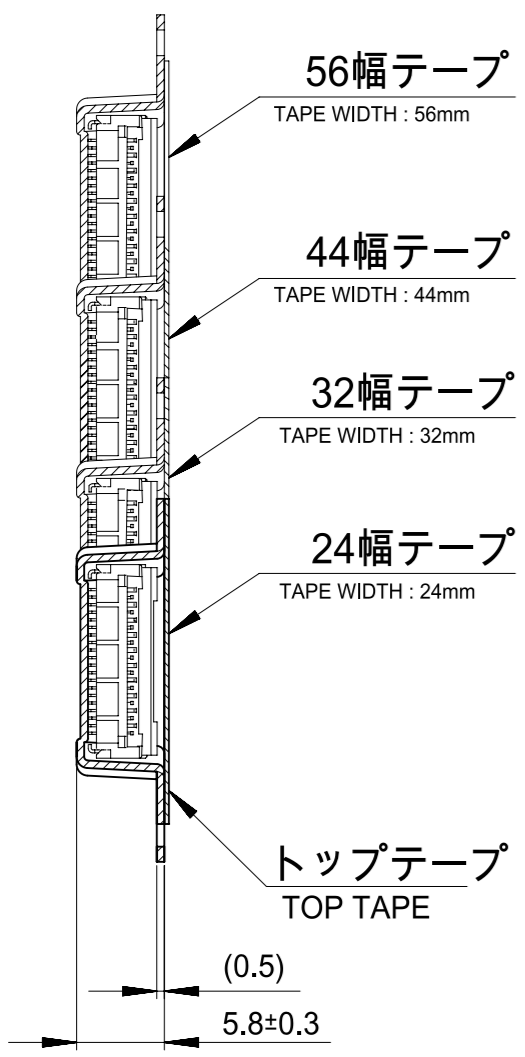

断面 Y-Y
SECTION Y-Y

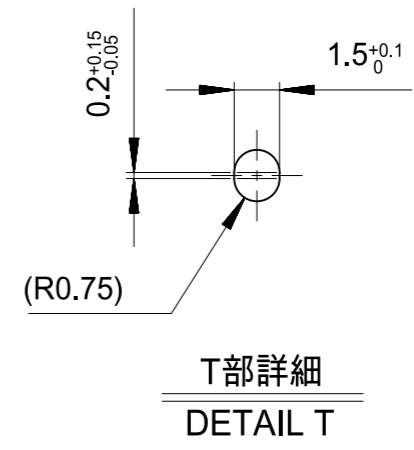
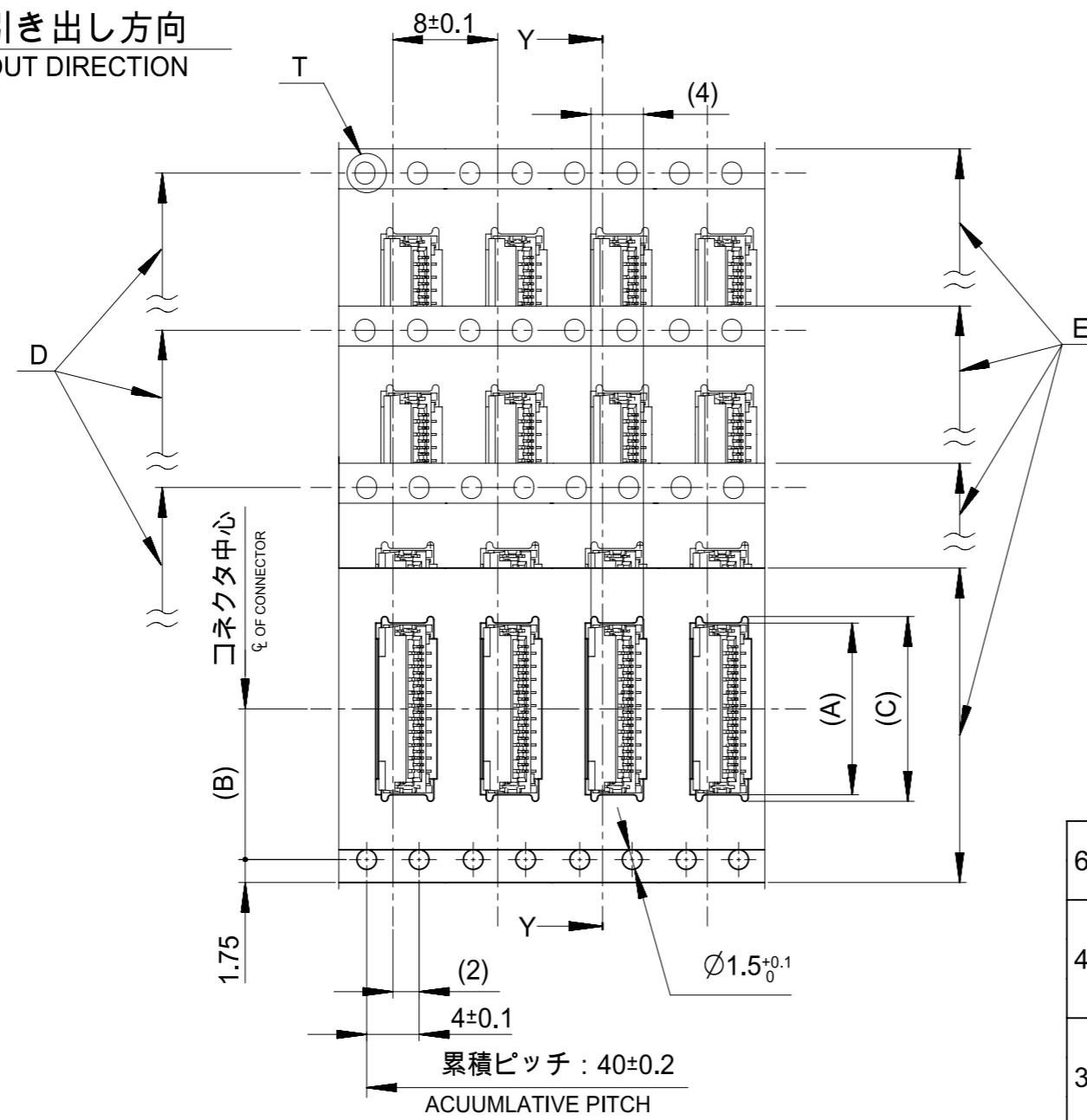

61.4	57.4	56±0.3	52.4	39.1	26.2	38.1	501951-7010	70
				34.1		33.1	501951-6010	60
49.4	45.4	44±0.3	40.4	29.1	20.2	28.1	501951-5010	50
				26.1		25.6	501951-4510	45
				24.1		23.1	501951-4010	40
37.4	33.4	32±0.3	28.4	20.1	14.2	19.1	501951-3210	32
				19.1		18.1	501951-3010	30
				16.1		15.1	501951-2410	24
29.4	25.4	24±0.3	-	15.1	11.5	14.1	501951-2210	22
				14.1		13.1	501951-2010	20
G	F	E CARRIER TAPE WIDTH		D	(C)	(B)	(A)	MATERIAL NO. CIRCUITS

THIS DRAWING CONTAINS INFORMATION THAT IS PROPRIETARY TO MOLEX ELECTRONIC TECHNOLOGIES, LLC AND SHOULD NOT BE USED WITHOUT WRITTEN PERMISSION

DIMENSION UNITS mm	SCALE 10:1	CURRENT REV DESC:		molex			
GENERAL TOLERANCES (UNLESS SPECIFIED)		EC NO: 601584					
ANGULAR TOL	± 1.0 °	DRWN: SKAWAKAMI 2018/09/21		PRODUCT CUSTOMER DRAWING			
4 PLACES	± 0.05	CHK'D: TRSUZUKI 2018/09/25		DOCUMENT NUMBER			
3 PLACES	± 0.1	APPR: RTAKEUCHI 2018/12/25		SD-501951-004			
2 PLACES	± 0.2	INITIAL REVISION:		DOC TYPE			
1 PLACE	± 0.25	DRWN: TRSUZUKI 2006/08/31		PSD			
0 PLACES	± 0.3	APPR: HHIRATA 2006/09/05		DOC PART			
DRAFT WHERE APPLICABLE MUST REMAIN WITHIN DIMENSIONS		THIRD ANGLE PROJECTION		SERIES		REVISION	
		DRAWING		501951		F	
		A3-SIZE		MATERIAL NUMBER		SHEET NUMBER	
				GENERAL MARKET		2 OF 2	

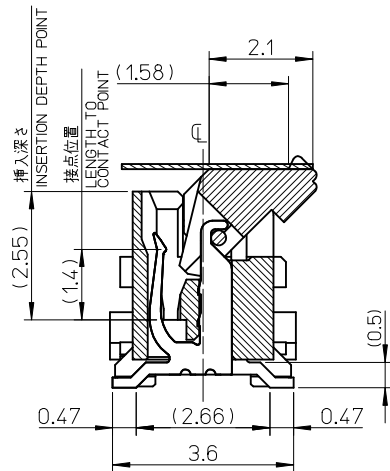
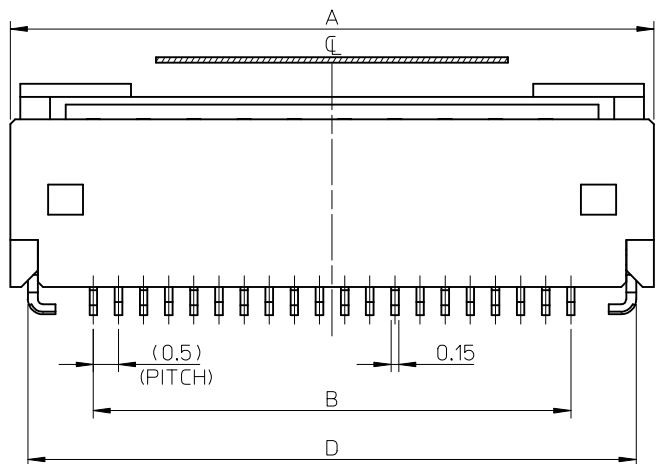
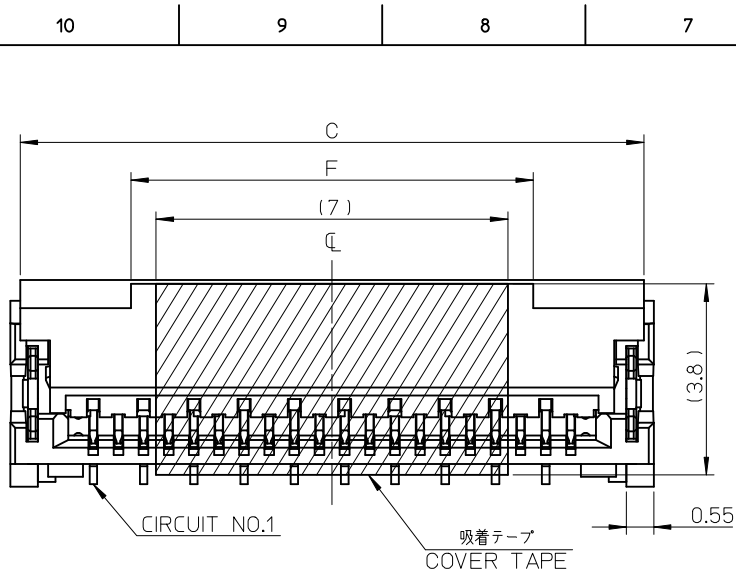

断面図 (参考)
SECTION (REFERENCE)

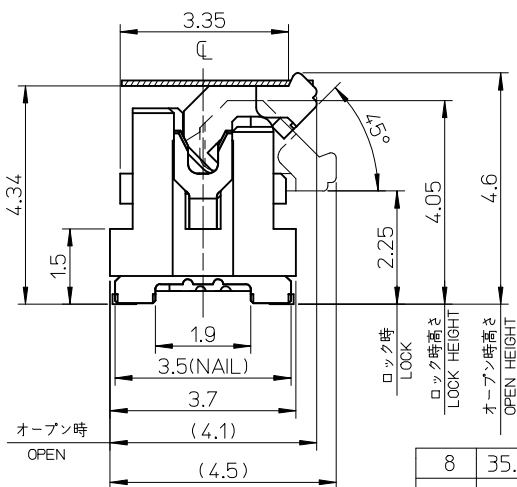

注記 NOTES

1. 使用材料 MATERIAL

- ハウジング : 液晶ポリマー ガラス充填, UL94V-0(白)
- HOUSING : LIQUID CRYSTAL POLYMER GLASS FILLED, UL94V-0 (WHITE)
- アクチュエータ : ポリアミド, ガラス充填, UL94V-0(茶)
- ACTUATOR : POLYAMIDE, GLASS FILLED, UL94V-0 (BROWN)
- ターミナル : 銅合金(t=0.15)
- TERMINAL : COPPER ALLOY
- 金具 : 銅合金(t=0.2)
- FITTING NAIL : COPPER ALLOY
- 吸着テープ : ポリアミド(t=0.125)
- COVER TAPE : POLYIMIDE(t=0.125)

2. めっき仕様 PLATING

- ターミナル TERMINAL
- コンタクト部: 部分金めっき 0.1マイクロメートル以上
- CONTACT AREA :SEPARATED GOLD PLATING 0.1μm MIN.
- テール部: 部分金めっき
- TAIL AREA :SEPARATED GOLD PLATING
- 下地: ニッケルめっき 1マイクロメートル以上
- UNDERPLATE: NICKEL OVERALL 1.0μm MIN.

金具 FITTING NAIL

- 銅めっき 1.0マイクロメートル以上
- TIN PLATING 1.0μm MIN.
- 下地: ニッケルめっき 1マイクロメートル以上
- UNDERPLATE: NICKEL OVERALL 1.0μm MIN.

3. テールと金具を併せた平坦度は 0.1ミリメートル以下
TAILS AND NAILS COPLANARITY TO BE 0.1 MAX.

4. ELV及びRoHS適合品
ELV AND RoHS COMPLIANT

△ R0.3は、FPC導体部にかからないこと。
R0.3 MUST NOT BE OVERLAPPED TO PATTERN OF FPC.

6. 本製品は 501951-7019 の吸着テープ付き品である。
THIS PRODUCT IS COVER TAPE VERSION OF 501951-7019.

8	35.7	37.1	37.4	34.5	37.8	501951-7020	501951-7029	70
F	E	D	C	B	A	EMBOSSED TAPE	製品番号	極数
						ORDER NO. オーダー番号	MATERIAL NO.	CIRCUITS

MODEL NO. 501951-**29

RELEASED EC NO: J2016-0731 DRWN: NKONDO 2016/01/14 CHKD: TAKAHASHI 2016/01/14 APPR: KMORIKAWA 2016/01/15	GENERAL TOLERANCES (UNLESS SPECIFIED)		DIMENSION STYLE MM ONLY		SCALE 10:1	DESIGN UNITS METRIC	THIRD ANGLE PROJECTION	
	0.25 UNDER	±0.2	DRAWN BY	DATE	TITLE			
	0.25 OVER 0.5 UNDER	±0.2	NKONDO	2016/01/14	0.5 FPC CONN. HSG ASSY EASY ON / STRAIGHT (GOLD)			
	0.5 OVER 1.0 UNDER	±0.2	CHECKED BY	DATE				
1.0 OVER 10 UNDER	±0.2	TAKAHASHI	2016/01/14					
10 OVER 30 UNDER	±0.25	APPROVED BY	DATE	MATERIAL NO.		DOCUMENT NO.	SHEET NO.	
30 OVER	±0.3	KMORIKAWA	2016/01/15	SEE CHART		SD-501951-009	1 OF 2	
ANGULAR ±1 °		DRAFT WHERE APPLICABLE MUST REMAIN WITHIN DIMENSIONS		SIZE A3	THIS DRAWING CONTAINS INFORMATION THAT IS PROPRIETARY TO MOLEX ELECTRONIC TECHNOLOGIES, LLC AND SHOULD NOT BE USED WITHOUT WRITTEN PERMISSION			

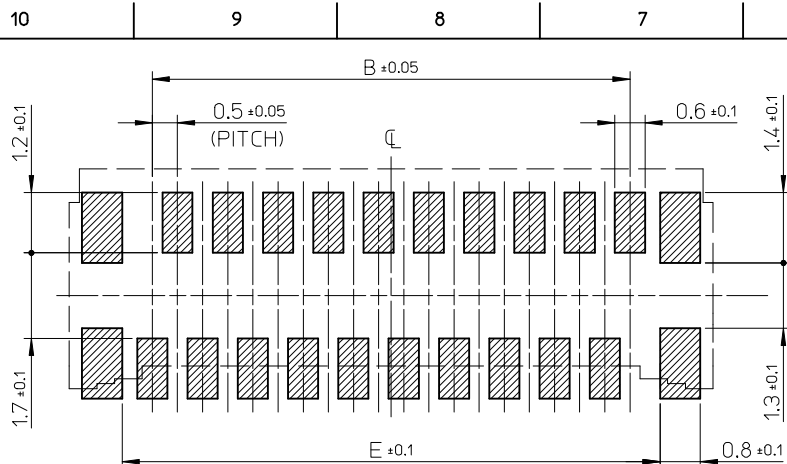

参考基板レイアウト (マウント面)

P.C.BOARD PATTERN DIMENSION(REF.)
(MOUNT AREA)

参考マスク厚: 120 μm
参考マスク開口率: 100%

REFERENCE SCREEN THICKNESS : 120 μm
REFERENCE SCREEN OPEN RATIO : 100%

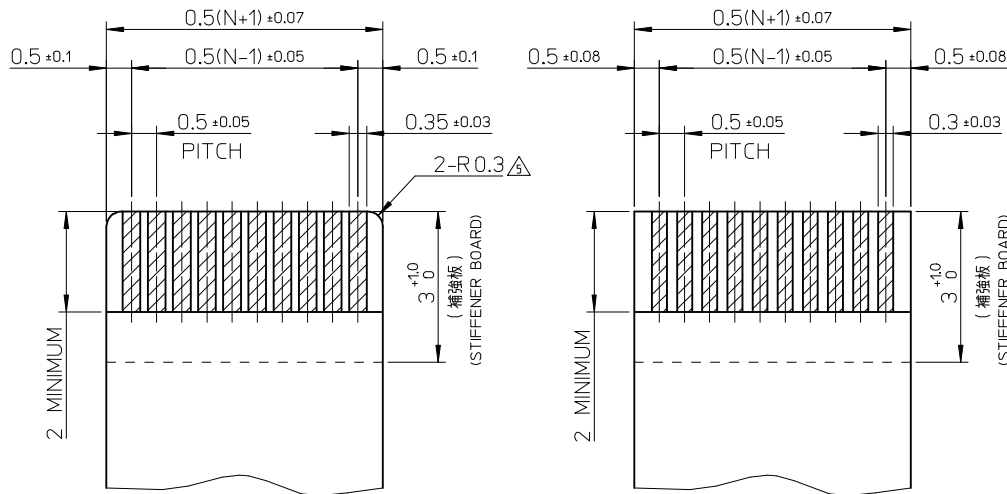

適合FPC推奨寸法
APPLICABLE FPC
RECOMMENDED DIMENSION
N:極数
N:CIRCUITS
(仕上がり厚さ: 0.3±0.03)
(THICKNESS: 0.3±0.03)

適合FFC推奨寸法
APPLICABLE FFC
RECOMMENDED DIMENSION
N:極数
N:CIRCUITS
(仕上がり厚さ: 0.3±0.03)
(THICKNESS: 0.3±0.03)

FPC について:

補強フィルム材質はポリイミドを推奨します。ベースフィルムは25 μmを推奨します。
接着剤は熱硬化接着剤を推奨します。
尚、接着剤の接点部への付着は導通不良の原因になりますので、染み出しが無い様お願い致します。

ABOUT FPC

RECOMMENDED STIFFENER MATERIAL: POLYIMIDE
RECOMMENDED BASE FILM THICKNESS: 25 MICROMETER
RECOMMENDED ADHESIVE: THERMOSETTING ADHESIVE
NOTE: PLEASE PUT APPROPRIATE AMOUNT OF ADHESIVE ON ADHEREND BECAUSE THERE IS A POSSIBILITY THAT THE EXTRA ADHESIVE CAUSES THE DEFECT IN ELECTRICAL CONTINUITY.

FPC/FFC について:

打ち抜き方向は導体側から補強板側を推奨します。
導体部については軟銅箔35 μmまたは50 μmを推奨します。
FFCに規定された定格温度がFPC単体前提である場合がございます。
コネクタと組み合わせての実使用において、接着層が劣化するなどの信頼性を満足できないケースを回避する為、実機での評価/確認をお願い致します。

ABOUT FPC/FFC

RECOMMENDED PUNCHER DIRECTION : FROM CONDUCTOR SIDE TO STIFFENER FILM SIDE.
RECOMMENDED CONDUCTOR SPEC: SOFT COPPER FOIL
RECOMMENDED CONDUCTOR THICKNESS: 35 MICROMETER OR 50 MICROMETER
NOTE: WHEN ACTUALLY USING IT WITH CONNECTOR, PLEASE DO THE EVALUATION AND THE CONFIRMATION WITH AN ACTUAL EQUIPMENT TO EVADE THE CASE WHERE RELIABILITY CANNOT BE FILLED (THE ADHESIVE LINE OF FFC IS DETERIORATED ETC.)

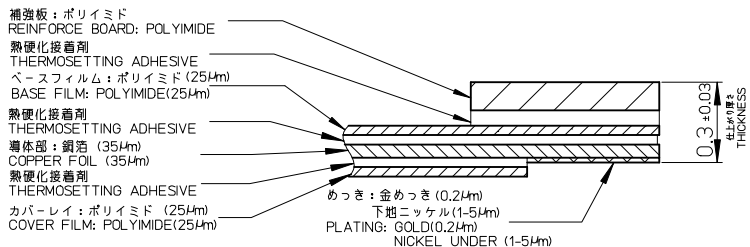

FPC構成推奨仕様
STRUCTURE OF FPC

RELEASED EC NO.: J2016-0731 O	DRWN: NKONDO 2016/01/14	CHKD: TAKAHASHI 2016/01/14	APPR: KMORIKAWA 2016/01/15	GENERAL TOLERANCES (UNLESS SPECIFIED)		DIMENSION STYLE MM ONLY		SCALE 10:1	DESIGN UNITS METRIC	THIRD ANGLE PROJECTION	
	DESCRIPTION			0.25 UNDER ±0.2	0.25 OVER ±0.2	0.5 UNDER ±0.2	0.5 OVER ±0.2	1.0 UNDER ±0.2	1.0 OVER ±0.2	10 UNDER ±0.25	30 OVER ±0.3
DRAWN BY DATE NKONDO 2016/01/14				CHECKED BY DATE TAKAHASHI 2016/01/14				APPROVED BY DATE KMORIKAWA 2016/01/15			
ANGULAR ±1 °						MATERIAL NO. SEE SHEET 1		DOCUMENT NO. SD-501951-009		SHEET NO. 2 OF 2	
DRAFT WHERE APPLICABLE MUST REMAIN WITHIN DIMENSIONS											
THIS DRAWING CONTAINS INFORMATION THAT IS PROPRIETARY TO MOLEX ELECTRONIC TECHNOLOGIES, LLC AND SHOULD NOT BE USED WITHOUT WRITTEN PERMISSION											