

32-Bit

Microcontroller

TC1793

32-Bit Single-Chip Microcontroller

Data Sheet

V 1.1.1 2012-12

Microcontrollers

Edition 2012-12

**Published by
Infineon Technologies AG
81726 Munich, Germany**

**© 2012 Infineon Technologies AG
All Rights Reserved.**

Legal Disclaimer

The information given in this document shall in no event be regarded as a guarantee of conditions or characteristics. With respect to any examples or hints given herein, any typical values stated herein and/or any information regarding the application of the device, Infineon Technologies hereby disclaims any and all warranties and liabilities of any kind, including without limitation, warranties of non-infringement of intellectual property rights of any third party.

Information

For further information on technology, delivery terms and conditions and prices, please contact the nearest Infineon Technologies Office (www.infineon.com).

Warnings

Due to technical requirements, components may contain dangerous substances. For information on the types in question, please contact the nearest Infineon Technologies Office.

Infineon Technologies components may be used in life-support devices or systems only with the express written approval of Infineon Technologies, if a failure of such components can reasonably be expected to cause the failure of that life-support device or system or to affect the safety or effectiveness of that device or system. Life support devices or systems are intended to be implanted in the human body or to support and/or maintain and sustain and/or protect human life. If they fail, it is reasonable to assume that the health of the user or other persons may be endangered.

32-Bit

Microcontroller

TC1793

32-Bit Single-Chip Microcontroller

Data Sheet

V 1.1.1 2012-12

Table of Contents

1	Summary of Features	1-1
2	System Overview of the TC1793	2-8
2.1	Block Diagram	2-9
3	Pinning	3-11
3.1	TC1793 Pin Configuration	3-12
4	Identification Registers	4-85
5	Electrical Parameters	5-87
5.1	General Parameters	5-87
5.1.1	Parameter Interpretation	5-87
5.1.2	Pad Driver and Pad Classes Summary	5-88
5.1.3	Absolute Maximum Ratings	5-89
5.1.4	Pin Reliability in Overload	5-91
5.1.5	Operating Conditions	5-93
5.1.5.1	Extended Range Operating Conditions	5-97
5.2	DC Parameters	5-100
5.2.1	Input/Output Pins	5-100
5.2.2	Analog to Digital Converters (ADCx)	5-118
5.2.3	Fast Analog to Digital Converter (FADC)	5-123
5.2.4	Oscillator Pins	5-127
5.2.5	Temperature Sensor	5-128
5.2.6	Power Supply Current	5-129
5.2.6.1	Calculating the 1.3 V Current Consumption	5-132
5.3	AC Parameters	5-134
5.3.1	Testing Waveforms	5-134
5.3.2	Power Sequencing	5-135
5.3.3	Power, Pad and Reset Timing	5-137
5.3.4	Phase Locked Loop (PLL)	5-139
5.3.5	ERAY Phase Locked Loop (ERAY_PLL)	5-142
5.3.6	JTAG Interface Timing	5-143
5.3.7	DAP Interface Timing	5-145
5.3.8	Micro Link Interface (MLI) Timing	5-146
5.3.9	Micro Second Channel (MSC) Interface Timing	5-149
5.3.10	SSC Master/Slave Mode Timing	5-151
5.3.11	ERAY Interface Timing	5-153
5.3.12	EBU Timings	5-155
5.3.12.1	BFCLKO Output Clock Timing	5-155
5.3.12.2	EBU Asynchronous Timings	5-155
5.3.12.3	EBU Burst Mode Access Timing	5-163

5.3.12.4	EBU Arbitration Signal Timing	5-166
5.4	Flash Memory Parameters	5-167
5.5	Package and Reliability	5-169
5.5.1	Package Parameters	5-169
5.5.2	Package Outline	5-170
5.5.3	Quality Declarations	5-170
6	History	6-1

1 Summary of Features

The **SAK-TC1793F-512F270EF / SAK-TC1793F-512F270EB** has the following features:

- High-performance 32-bit super-scalar TriCore V1.6 CPU with 6-stage pipeline
 - Superior real-time performance
 - Strong bit handling
 - Fully integrated DSP capabilities
 - Multiply-accumulate unit able to sustain 2 MAC operations per cycle
 - Fully pipelined Floating point unit (FPU)
 - 270 MHz operation at full temperature range
- 32-bit Peripheral Control Processor with single cycle instruction (PCP2)
 - 16 Kbyte Parameter Memory (PRAM)
 - 32 Kbyte Code Memory (CMEM)
 - 200 MHz operation at full temperature range
- Multiple on-chip memories
 - 4 Mbyte Program Flash Memory (PFLASH) with ECC
 - 192 Kbyte Data Flash Memory (DFLASH) usable for EEPROM emulation
 - 2 x 8 Kbyte Key Flash
 - 128 Kbyte Data Scratch-Pad RAM (DSPR)
 - 16 Kbyte Instruction Cache (ICACHE)
 - 32 Kbyte Instruction Scratch-Pad RAM (PSPR)
 - 16 Kbyte Data Cache (DACHE)
 - 128 Kbyte Memory (SRAM)
 - 16 Kbyte BootROM (BROM)
- 16-Channel DMA Controller
- 8-Channel Safe DMA (SDMA) Controller
- Sophisticated interrupt system with 2 × 255 hardware priority arbitration levels serviced by CPU or PCP2
- High performing on-chip bus structure
 - 64-bit Cross Bar Interconnect between CPU, Flash and Data Memory
 - 32-bit System Peripheral Bus (SPB) for on-chip peripheral and functional units
 - One bus bridge (SFI Bridge)
- Versatile On-chip Peripheral Units
 - Two Asynchronous/Synchronous Serial Channels (ASC) with baud rate generator, parity, framing and overrun error detection
 - Four High-Speed Synchronous Serial Channels (SSC) with programmable data length and shift direction
 - Four SSC Guardian (SSCG) modules, one for each SSC
 - Two serial Micro Second Bus interfaces (MSC) for serial port expansion to external power devices
 - Two High-Speed Micro Link interfaces (MLI) for serial inter-processor communication

Summary of Features

- One External Bus Interface (EBU) supporting different memories: asynchronous memories e.g. SRAM, peripheral devices; synchronous devices e.g. burst NOR flash, PSRAM; and DDR NOR flash e.g. LPDDR-NVM (Jedec 42.2), ONFI 2.0 (limited frequency at 1.8 V I/O supply)
- One MultiCAN Module with 4 CAN nodes and 128 free assignable message objects for high efficiency data handling via FIFO buffering and gateway data transfer (one CAN node supports TTCAN functionality)
- One FlexRay™ module with 2 channels (E-Ray).
- Two General Purpose Timer Array Modules (GPTA) with additional Local Timer Cell Array (LTCA2) providing a powerful set of digital signal filtering and timer functionality to realize autonomous and complex Input/Output management
- Two Capture / Compare 6 modules
- Two General Purpose 12 Timer Units (GPT120 and GPT121)
- 44 analog input lines for ADC
 - 4 independent kernels (ADC0, ADC1, and ADC2)
 - Analog supply voltage range from 3.3 V to 5 V (single supply)
- 4 different FADC input channels
 - channels with impedance control and overlaid with ADC1 inputs
 - Extreme fast conversion, 21 cycles of f_{FADC} clock
 - 10-bit A/D conversion (higher resolution can be achieved by averaging of consecutive conversions in digital data reduction filter)
- 8 digital input lines for SENT
 - communication according to the SENT specification J2716 FEB2008
- 221 digital general purpose I/O lines (GPIO)
- Digital I/O ports with 3.3 V capability
- On-chip debug support for OCDS Level 1 (CPU, PCP, DMA, On Chip Buses)
- Dedicated Emulation Device chip available (TC1793ED)
 - multi-core debugging, real time tracing, and calibration
 - four/five wire JTAG (IEEE 1149.1) or two wire DAP (Device Access Port) interface
- Power Management System
- Clock Generation Unit with PLL and PLL_ERAY
- Flexible CRC Engine (FCE)
 - IEEE 802.3 CRC32 ethernet polynomial: 0x82608EDB (CRC kernel 0)
 - CRC32C Castagnoli: 0xD419CC15 (CRC kernel 1)

The **SAK-TC1793F-512F200EB / SAK-TC1793F-512F200EF** has the following features:

- High-performance 32-bit super-scalar TriCore V1.6 CPU with 6-stage pipeline
 - Superior real-time performance
 - Strong bit handling
 - Fully integrated DSP capabilities
 - Multiply-accumulate unit able to sustain 2 MAC operations per cycle
 - Fully pipelined Floating point unit (FPU)

Summary of Features

- 200 MHz operation at full temperature range
- 32-bit Peripheral Control Processor with single cycle instruction (PCP2)
 - 16 Kbyte Parameter Memory (PRAM)
 - 32 Kbyte Code Memory (CMEM)
 - 200 MHz operation at full temperature range
- Multiple on-chip memories
 - 4 Mbyte Program Flash Memory (PFLASH) with ECC
 - 192 Kbyte Data Flash Memory (DFLASH) usable for EEPROM emulation
 - 2 x 8 Kbyte Key Flash
 - 128 Kbyte Data Scratch-Pad RAM (DSPR)
 - 16 Kbyte Instruction Cache (ICACHE)
 - 32 Kbyte Instruction Scratch-Pad RAM (PSPR)
 - 16 Kbyte Data Cache (DACHE)
 - 128 Kbyte Memory (SRAM)
 - 16 Kbyte BootROM (BROM)
- 16-Channel DMA Controller
- 8-Channel Safe DMA (SDMA) Controller
- Sophisticated interrupt system with 2 × 255 hardware priority arbitration levels serviced by CPU or PCP2
- High performing on-chip bus structure
 - 64-bit Cross Bar Interconnect between CPU, Flash and Data Memory
 - 32-bit System Peripheral Bus (SPB) for on-chip peripheral and functional units
 - One bus bridge (SFI Bridge)
- Versatile On-chip Peripheral Units
 - Two Asynchronous/Synchronous Serial Channels (ASC) with baud rate generator, parity, framing and overrun error detection
 - Four High-Speed Synchronous Serial Channels (SSC) with programmable data length and shift direction
 - Four SSC Guardian (SSCG) modules, one for each SSC
 - Two serial Micro Second Bus interfaces (MSC) for serial port expansion to external power devices
 - Two High-Speed Micro Link interfaces (MLI) for serial inter-processor communication
 - One External Bus Interface (EBU) supporting different memories: asynchronous memories e.g. SRAM, peripheral devices; synchronous devices e.g. burst NOR flash, PSRAM; and DDR NOR flash e.g. LPDDR-NVM (Jedec 42.2), ONFI 2.0 (limited frequency at 1.8 V I/O supply)
 - One MultiCAN Module with 4 CAN nodes and 128 free assignable message objects for high efficiency data handling via FIFO buffering and gateway data transfer (one CAN node supports TTCAN functionality)
 - One FlexRay™ module with 2 channels (E-Ray).

Summary of Features

- Two General Purpose Timer Array Modules (GPTA) with additional Local Timer Cell Array (LTCA2) providing a powerful set of digital signal filtering and timer functionality to realize autonomous and complex Input/Output management
- Two Capture / Compare 6 modules
- Two General Purpose 12 Timer Units (GPT120 and GPT121)
- 44 analog input lines for ADC
 - 4 independent kernels (ADC0, ADC1, and ADC2)
 - Analog supply voltage range from 3.3 V to 5 V (single supply)
- 4 different FADC input channels
 - channels with impedance control and overlaid with ADC1 inputs
 - Extreme fast conversion, 21 cycles of f_{FADC} clock
 - 10-bit A/D conversion (higher resolution can be achieved by averaging of consecutive conversions in digital data reduction filter)
- 8 digital input lines for SENT
 - communication according to the SENT specification J2716 FEB2008
- 221 digital general purpose I/O lines (GPIO)
- Digital I/O ports with 3.3 V capability
- On-chip debug support for OCDS Level 1 (CPU, PCP, DMA, On Chip Buses)
- Dedicated Emulation Device chip available (TC1793ED)
 - multi-core debugging, real time tracing, and calibration
 - four/five wire JTAG (IEEE 1149.1) or two wire DAP (Device Access Port) interface
- Power Management System
- Clock Generation Unit with PLL and PLL_ERAY
- Flexible CRC Engine (FCE)
 - IEEE 802.3 CRC32 ethernet polynomial: 0x82608EDB (CRC kernel 0)
 - CRC32C Castagnoli: 0xD419CC15 (CRC kernel 1)

The **SAK-TC1793N-512F270EF** has the following features:

- High-performance 32-bit super-scalar TriCore V1.6 CPU with 6-stage pipeline
 - Superior real-time performance
 - Strong bit handling
 - Fully integrated DSP capabilities
 - Multiply-accumulate unit able to sustain 2 MAC operations per cycle
 - Fully pipelined Floating point unit (FPU)
 - 270 MHz operation at full temperature range
- 32-bit Peripheral Control Processor with single cycle instruction (PCP2)
 - 16 Kbyte Parameter Memory (PRAM)
 - 32 Kbyte Code Memory (CMEM)
 - 200 MHz operation at full temperature range
- Multiple on-chip memories
 - 4 Mbyte Program Flash Memory (PFLASH) with ECC
 - 192 Kbyte Data Flash Memory (DFLASH) usable for EEPROM emulation
 - 2 x 8 Kbyte Key Flash

Summary of Features

- 128 Kbyte Data Scratch-Pad RAM (DSPR)
- 16 Kbyte Instruction Cache (ICACHE)
- 32 Kbyte Instruction Scratch-Pad RAM (PSPR)
- 16 Kbyte Data Cache (DACHE)
- 128 Kbyte Memory (SRAM)
- 16 Kbyte BootROM (BROM)
- 16-Channel DMA Controller
- 8-Channel Safe DMA (SDMA) Controller
- Sophisticated interrupt system with 2×255 hardware priority arbitration levels serviced by CPU or PCP2
- High performing on-chip bus structure
 - 64-bit Cross Bar Interconnect between CPU, Flash and Data Memory
 - 32-bit System Peripheral Bus (SPB) for on-chip peripheral and functional units
 - One bus bridge (SFI Bridge)
- Versatile On-chip Peripheral Units
 - Two Asynchronous/Synchronous Serial Channels (ASC) with baud rate generator, parity, framing and overrun error detection
 - Four High-Speed Synchronous Serial Channels (SSC) with programmable data length and shift direction
 - Four SSC Guardian (SSCG) modules, one for each SSC
 - Two serial Micro Second Bus interfaces (MSC) for serial port expansion to external power devices
 - Two High-Speed Micro Link interfaces (MLI) for serial inter-processor communication
 - One External Bus Interface (EBU) supporting different memories: asynchronous memories e.g. SRAM, peripheral devices; synchronous devices e.g. burst NOR flash, PSRAM; and DDR NOR flash e.g. LPDDR-NVM (Jedec 42.2), ONFI 2.0 (limited frequency at 1.8 V I/O supply)
 - One MultiCAN Module with 4 CAN nodes and 128 free assignable message objects for high efficiency data handling via FIFO buffering and gateway data transfer (one CAN node supports TTCAN functionality)
 - Two General Purpose Timer Array Modules (GPTA) with additional Local Timer Cell Array (LTCA2) providing a powerful set of digital signal filtering and timer functionality to realize autonomous and complex Input/Output management
 - Two Capture / Compare 6 modules
 - Two General Purpose 12 Timer Units (GPT120 and GPT121)
- 44 analog input lines for ADC
 - 4 independent kernels (ADC0, ADC1, and ADC2)
 - Analog supply voltage range from 3.3 V to 5 V (single supply)
- 4 different FADC input channels
 - channels with impedance control and overlaid with ADC1 inputs
 - Extreme fast conversion, 21 cycles of f_{FADC} clock

Summary of Features

- 10-bit A/D conversion (higher resolution can be achieved by averaging of consecutive conversions in digital data reduction filter)
- 8 digital input lines for SENT
 - communication according to the SENT specification J2716 FEB2008
- 221 digital general purpose I/O lines (GPIO)
- Digital I/O ports with 3.3 V capability
- On-chip debug support for OCDS Level 1 (CPU, PCP, DMA, On Chip Buses)
- Dedicated Emulation Device chip available (TC1793ED)
 - multi-core debugging, real time tracing, and calibration
 - four/five wire JTAG (IEEE 1149.1) or two wire DAP (Device Access Port) interface
- Power Management System
- Clock Generation Unit with PLL and PLL_ERAY
- Flexible CRC Engine (FCE)
 - IEEE 802.3 CRC32 ethernet polynomial: 0x82608EDB (CRC kernel 0)
 - CRC32C Castagnoli: 0xD419CC15 (CRC kernel 1)

The **SAK-TC1793S-512F270EF** has the following features:

- High-performance 32-bit super-scalar TriCore V1.6 CPU with 6-stage pipeline
 - Superior real-time performance
 - Strong bit handling
 - Fully integrated DSP capabilities
 - Multiply-accumulate unit able to sustain 2 MAC operations per cycle
 - Fully pipelined Floating point unit (FPU)
 - 270 MHz operation at full temperature range
- 32-bit Peripheral Control Processor with single cycle instruction (PCP2)
 - 16 Kbyte Parameter Memory (PRAM)
 - 32 Kbyte Code Memory (CMEM)
 - 200 MHz operation at full temperature range
- Multiple on-chip memories
 - 4 Mbyte Program Flash Memory (PFLASH) with ECC
 - 192 Kbyte Data Flash Memory (DFLASH) usable for EEPROM emulation
 - 2 x 8 Kbyte Key Flash
 - 128 Kbyte Data Scratch-Pad RAM (DSPR)
 - 16 Kbyte Instruction Cache (ICACHE)
 - 32 Kbyte Instruction Scratch-Pad RAM (PSPR)
 - 16 Kbyte Data Cache (DACHE)
 - 128 Kbyte Memory (SRAM)
 - 16 Kbyte BootROM (BROM)
- 16-Channel DMA Controller
- 8-Channel Safe DMA (SDMA) Controller
- Sophisticated interrupt system with 2 x 255 hardware priority arbitration levels serviced by CPU or PCP2
- High performing on-chip bus structure

Summary of Features

- 64-bit Cross Bar Interconnect between CPU, Flash and Data Memory
- 32-bit System Peripheral Bus (SPB) for on-chip peripheral and functional units
- One bus bridge (SFI Bridge)
- Versatile On-chip Peripheral Units
 - Two Asynchronous/Synchronous Serial Channels (ASC) with baud rate generator, parity, framing and overrun error detection
 - Four High-Speed Synchronous Serial Channels (SSC) with programmable data length and shift direction
 - Four SSC Guardian (SSCG) modules, one for each SSC
 - Two serial Micro Second Bus interfaces (MSC) for serial port expansion to external power devices
 - Two High-Speed Micro Link interfaces (MLI) for serial inter-processor communication
 - One External Bus Interface (EBU) supporting different memories: asynchronous memories e.g. SRAM, peripheral devices; synchronous devices e.g. burst NOR flash, PSRAM; and DDR NOR flash e.g. LPDDR-NVM (Jedec 42.2), ONFI 2.0 (limited frequency at 1.8 V I/O supply)
 - One MultiCAN Module with 4 CAN nodes and 128 free assignable message objects for high efficiency data handling via FIFO buffering and gateway data transfer (one CAN node supports TTCAN functionality)
 - One FlexRay™ module with 2 channels (E-Ray).
 - Two General Purpose Timer Array Modules (GPTA) with additional Local Timer Cell Array (LTCA2) providing a powerful set of digital signal filtering and timer functionality to realize autonomous and complex Input/Output management
 - Two Capture / Compare 6 modules
 - Two General Purpose 12 Timer Units (GPT120 and GPT121)
- 44 analog input lines for ADC
 - 4 independent kernels (ADC0, ADC1, and ADC2)
 - Analog supply voltage range from 3.3 V to 5 V (single supply)
- 4 different FADC input channels
 - channels with impedance control and overlaid with ADC1 inputs
 - Extreme fast conversion, 21 cycles of f_{FADC} clock
 - 10-bit A/D conversion (higher resolution can be achieved by averaging of consecutive conversions in digital data reduction filter)
- 8 digital input lines for SENT
 - communication according to the SENT specification J2716 FEB2008
- 221 digital general purpose I/O lines (GPIO)
- Digital I/O ports with 3.3 V capability
- On-chip debug support for OCDS Level 1 (CPU, PCP, DMA, On Chip Buses)
- Dedicated Emulation Device chip available (TC1793ED)
 - multi-core debugging, real time tracing, and calibration
 - four/five wire JTAG (IEEE 1149.1) or two wire DAP (Device Access Port) interface
- Power Management System

Summary of Features

- Clock Generation Unit with PLL and PLL_ERAY
- Flexible CRC Engine (FCE)
 - IEEE 802.3 CRC32 ethernet polynomial: 0x82608EDB (CRC kernel 0)
 - CRC32C Castagnoli: 0xD419CC15 (CRC kernel 1)
- Secure Hardware Extension (SHE)
 - For further information please contact your Infineon representative

Ordering Information

The ordering code for Infineon microcontrollers provides an exact reference to the required product. This ordering code identifies:

- The derivative itself, i.e. its function set, the temperature range, and the supply voltage
- The package and the type of delivery.

For the available ordering codes for the TC1793 please refer to the “**Product Catalog Microcontrollers**”, which summarizes all available microcontroller variants.

This document describes the derivatives of the device. The **Table 1** enumerates these derivatives and summarizes the differences.

Table 1 TC1793 Derivative Synopsis

Derivative	Ambient Temperature Range
SAK-TC1793F-512F270EF	$T_A = -40^{\circ}\text{C}$ to $+125^{\circ}\text{C}$
SAK-TC1793F-512F270EB	$T_A = -40^{\circ}\text{C}$ to $+125^{\circ}\text{C}$
SAK-TC1793F-512F200EF	$T_A = -40^{\circ}\text{C}$ to $+125^{\circ}\text{C}$
SAK-TC1793F-512F200EB	$T_A = -40^{\circ}\text{C}$ to $+125^{\circ}\text{C}$
SAK-TC1793N-512F270EF	$T_A = -40^{\circ}\text{C}$ to $+125^{\circ}\text{C}$
SAK-TC1793S-512F270EF	$T_A = -40^{\circ}\text{C}$ to $+125^{\circ}\text{C}$

2 System Overview of the TC1793

The TC1793 combines three powerful technologies within one silicon die, achieving new levels of power, speed, and economy for embedded applications:

- Reduced Instruction Set Computing (RISC) processor architecture
- Digital Signal Processing (DSP) operations and addressing modes
- On-chip memories and peripherals

DSP operations and addressing modes provide the computational power necessary to efficiently analyze complex real-world signals. The RISC load/store architecture provides high computational bandwidth with low system cost. On-chip memory and peripherals are designed to support even the most demanding high-bandwidth real-time embedded control-systems tasks.

Additional high-level features of the TC1793 include:

- Efficient memory organization: instruction and data scratch memories, caches
- Serial communication interfaces – flexible synchronous and asynchronous modes
- Peripheral Control Processor – standalone data operations and interrupt servicing
- DMA Controller – DMA operations and interrupt servicing
- General-purpose timers
- High-performance on-chip buses
- On-chip debugging and emulation facilities
- Flexible interconnections to external components
- Flexible power-management

The TC1793 is a high-performance microcontroller with TriCore CPU, program and data memories, buses, bus arbitration, an interrupt controller, a peripheral control processor and a DMA controller and several on-chip peripherals. The TC1793 is designed to meet the needs of the most demanding embedded control systems applications where the competing issues of price/performance, real-time responsiveness, computational power, data bandwidth, and power consumption are key design elements.

The TC1793 offers several versatile on-chip peripheral units such as serial controllers, timer units, and Analog-to-Digital converters. Within the TC1793, all these peripheral units are connected to the TriCore CPU/system via the Flexible Peripheral Interconnect (FPI) Bus and the Cross Bar Interconnect (SRI). Several I/O lines on the TC1793 ports are reserved for these peripheral units to communicate with the external world.

System Overview of the TC1793Block Diagram

2.1 Block Diagram

Figure 1 shows the block diagram of the SAK-TC1793F-512F270EF / SAK-TC1793F-512F270EB / SAK-TC1793F-512F200EF / SAK-TC1793F-512F200EB.

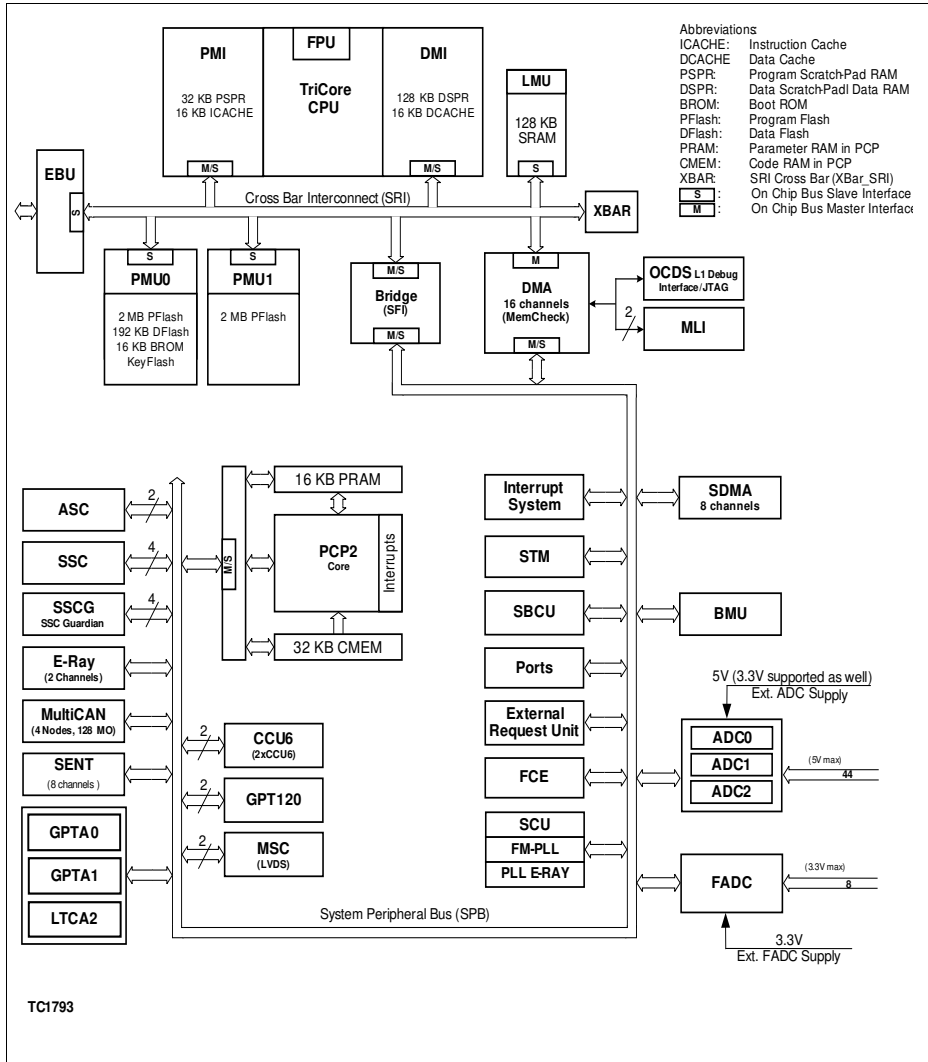

Figure 1 Block Diagram

System Overview of the TC1793Block Diagram

Figure 2 shows the block diagram of the SAK-TC1793N-512F270EF.

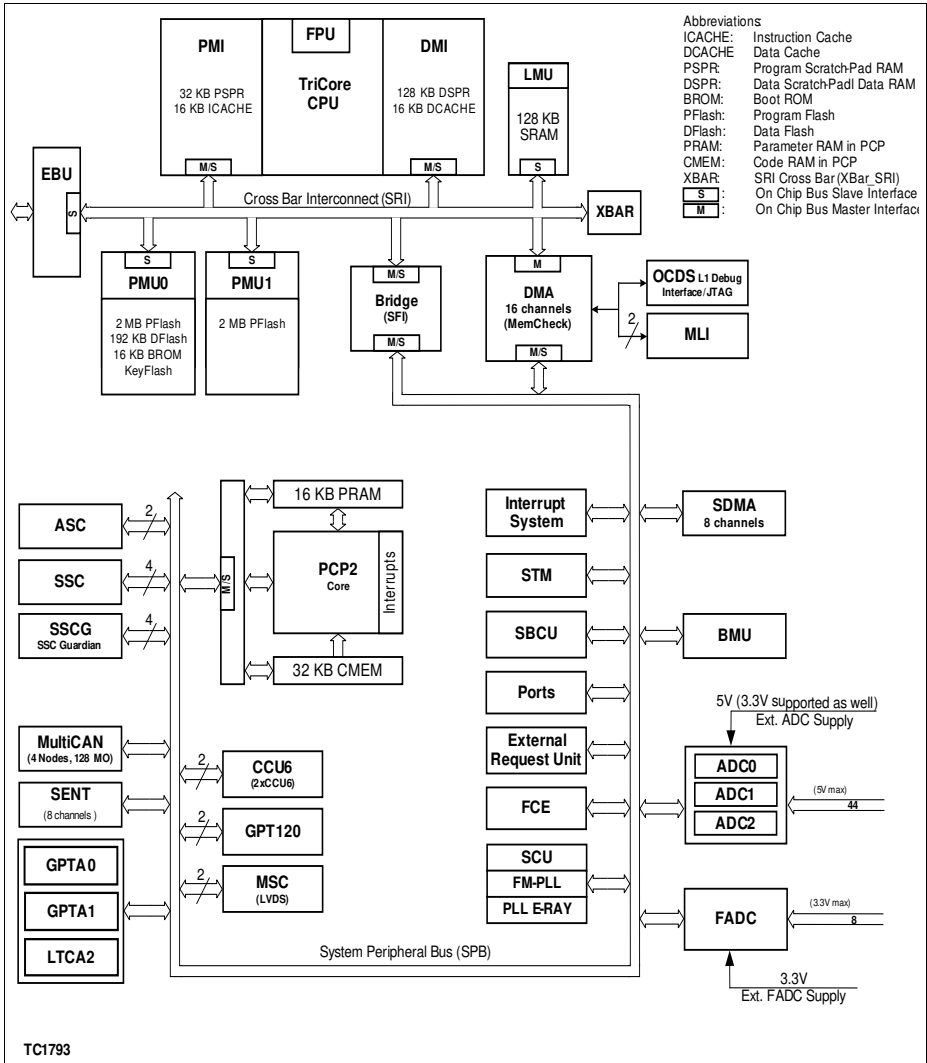

Figure 2 Block Diagram

System Overview of the TC1793Block Diagram

Figure 3 shows the block diagram of the SAK-TC1793S-512F270EF.

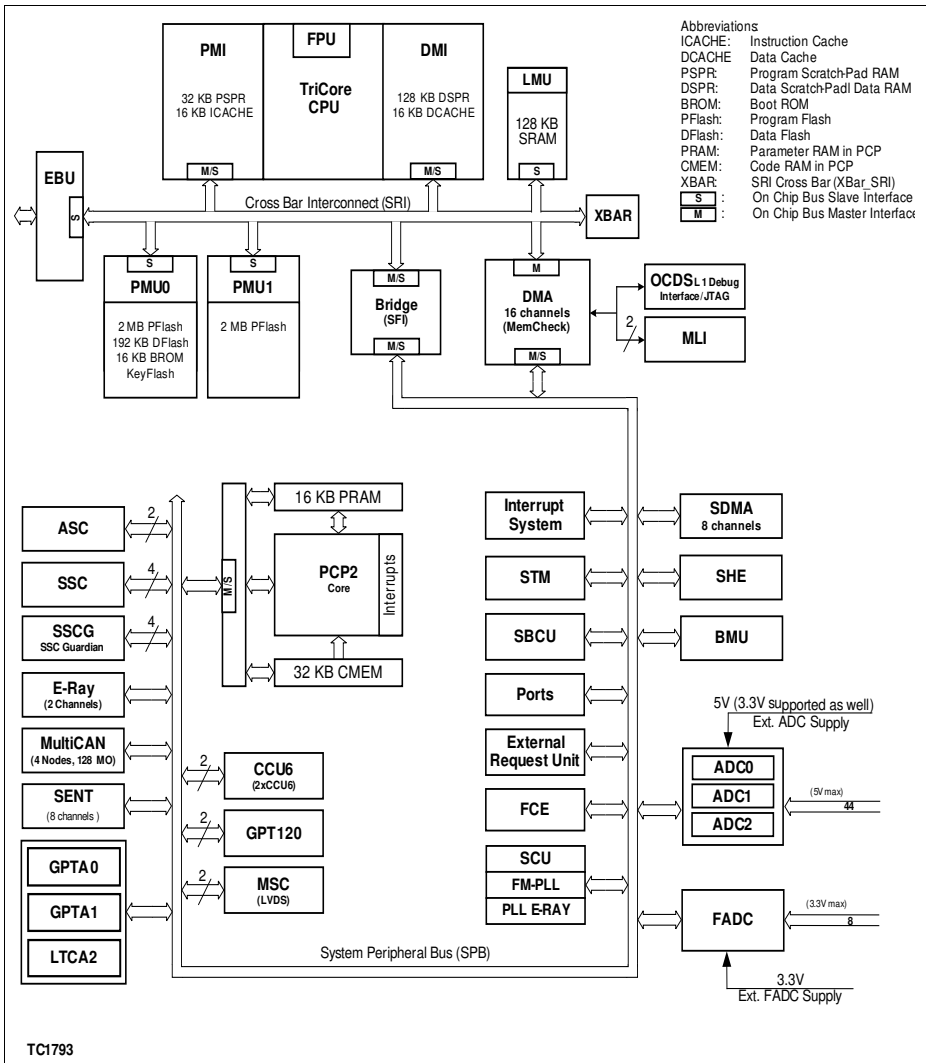

Figure 3 Block Diagram

3 Pinning

Figure 3 is showing the TC1793 Logic Symbol.

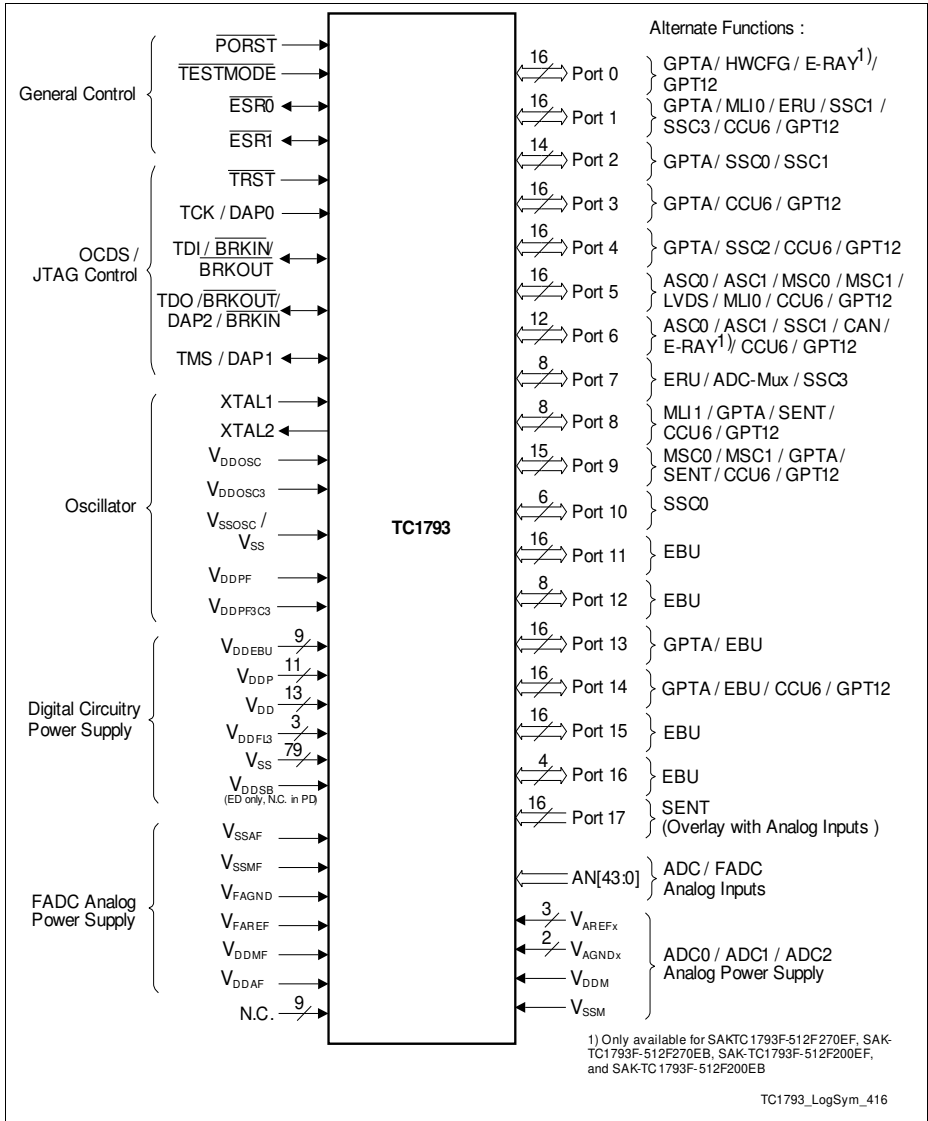

Figure 3 TC1793 Logic Symbol

Pinning TC1793 Pin Configuration

3.1 TC1793 Pin Configuration

This chapter shows the pin configuration of the TC1793 package PG-BGA- 416.

	1	2	3	4	5	6	7	8	9	10	11	12	13	14	15	16	17	18	19	20	21	22	23	24	25	26	
A	N.C.	P2.9	P2.13	P2.15	P0.14	P0.5	P0.2	P0.1	P0.0	P3.14	P3.5	P3.1	P5.1	P5.2	P5.7	P5.12	P5.15	V _{DDFL3}	P9.0	P9.3	P9.9	ESR1	ESR0	N.C.	V _{DDP}	V _{SS}	
B	P2.6	P2.7	P2.10	P2.14	P0.9	P0.6	P0.4	P0.3	P3.15	P3.6	P3.3	P3.0	P5.0	P5.3	P5.6	P5.13	P5.14	V _{DDFL3}	P9.1	P9.2	P9.10	PD RST	TEST MODE	V _{DDP}	V _{SS}	V _{DD}	
C	P2.5	P2.8	P2.11	P2.12	P0.12	P0.10	P0.8	P0.7	P3.7	P3.10	P3.9	P3.4	P3.2	P5.5	P5.4	P5.9	P5.10	P5.11	P9.6	P9.8	P9.11	N.C.	V _{DDP}	V _{SS}	V _{DD}	P9.13	
D	P2.4	P2.3	P2.2	P0.15	P0.13	P0.11	V _{DDP}	V _{SS}	V _{DD}	P3.8	P3.12	P3.13	P3.11	V _{DDP}	V _{SS}	V _{DD}	P5.8	P9.4	P9.5	P9.7	P9.12	V _{DDP}	V _{SS}	V _{DD}	TDO	P9.14	
E	P6.12	P6.11	P6.6	P6.9																		V _{DD}	TCK	TDI	V _{DD}	V _{OSC3}	
F	P6.14	P6.10	P6.4	P6.8																		TRST	TMS	V _{SS}	V _{OSC}	V _{DD}	V _{OSC}
G	P6.15	P6.13	P6.7	P6.5																		V _{DDOFF}	V _{DDPFS3}	XTAL 2	XTAL 1		
H	P8.1	P8.0	V _{DDFL3}	V _{DD}																		V _{DDDEBU}	V _{DDDEBU}	V _{DDDEBU}	V _{DDDEBU}		
J	P8.4	P8.3	P8.2	V _{SS}																		P11.3	P12.6	P12.7	P11.0		
K	P8.7	P8.5	P8.6	V _{DDP}																		P11.7	P11.4	P11.1	P11.2		
L	P1.15	P1.14	P1.13	P1.11																		V _{SS}	V _{SS}	V _{SS}	V _{SS}		
M	P1.10	P1.9	P1.8	P1.5																		V _{DDDEBU}	P11 10	P11.9	P11.8		
N	P1.3	P1.7	P1.6	P1.4																		P11 13	P11 14	P11 15	P11 12		
P	P1.2	P1.1	P1.0	P1.12																		V _{DD}	P12.1	P12.2	P12.0		
R	V _{DD} SBRAM	P7.1	P7.0	V _{DD}																		V _{SS}	P12.3	P12.5	P12.4		
T	P7.6	P7.5	P7.4	V _{SS}																		V _{DDDEBU}	P13.1	P13.3	P13.0		
U	AN23	P7.7	P7.3	P7.2																		P13.6	P13.9	P13.5	P13.2		
V	AN22	AN21	AN19	AN16																		V _{DD}	P13 13	P13.8	P13.4		
W	AN20	AN17	AN13	V _{DDIM}																		V _{SS}	P14.0	P13 12	P13.7		
Y	AN18	AN14	AN10	V _{SSIM}																		V _{DDDEBU}	P14.2	P13 14	P13 10		
AA	AN15	AN11	AN5	AN2																		P14.3	P14.6	P14.1	P13 11		
AB	AN12	AN9	AN3	AN7																		V _{DD}	P14.5	P14.4	P13 15		
AC	AN8	AN4	AN32	AN38	AN42	V _{AREND1}	AN26	AN24	V _{DDAF}	V _{SS}	V _{DD}	P4.4	P4.8	P4.12	P10.5	V _{DDP}	V _{SS}	V _{DDDEBU}	V _{SS}	V _{DD}	N.C.	V _{DDDEBU}	V _{SS}	P14 12	P14.9	P14.7	
AD	AN6	AN1	AN34	AN40	AN35	V _{AREF1}	AN27	AN25	V _{AREF2}	P4.0	P4.2	P4.5	P4.11	P4.15	P10.2	V _{DDP}	P15.5	P16.1	P15.3	P15.2	P15.1	P16.2	N.C.	P14 15	P14 11	P14.8	
AE	AN0	AN33	AN36	AN41	V _{AREF0}	AN28	AN30	V _{AREND2}	V _{DDAF}	P4.1	P4.3	P4.7	P4.13	P10.4	P10.0	V _{DDP}	P15.4	P15.7	P16.3	P15 11	P15.0	N.C.	N.C.	P14 14	P14 13	P14 10	
AF	N.C.	AN37	AN39	AN43	V _{AREND3}	AN29	AN31	V _{AREF}	V _{SSIMF}	P4.6	P4.9	P4.10	P4.14	P10.3	P10.1	V _{DDP}	P16.0	P15.6	P15 12	P15.8	P15.9	P15 10	P15 13	P15 14	P15 15	N.C.	
	1	2	3	4	5	6	7	8	9	10	11	12	13	14	15	16	17	18	19	20	21	22	23	24	25	26	

mca05584_97.vsd

Figure 4 TC1793 Pinning for PG-BGA- 416 Package

Table 2 Pin Definitions and Functions

Pin	Symbol	Ctrl.	Type	Function
Port 0				
A9	P0.0	I/O	A1+/ PU	Port 0 General Purpose I/O Line 0
	HWCFG0	I		Hardware Configuration Input 0
	OUT56	O1		OUT56 Line of GPTA0
	OUT56	O2		OUT56 Line of GPTA1
	OUT80	O3		OUT80 Line of LTCA2
A8	P0.1	I/O	A1/ PU	Port 0 General Purpose I/O Line 1
	HWCFG1	I		Hardware Configuration Input 1
	OUT57	O1		OUT57 Line of GPTA0
	OUT57	O2		OUT57 Line of GPTA1
	OUT81	O3		OUT81 Line of LTCA2
A7	P0.2	I/O	A2/ PU	Port 0 General Purpose I/O Line 2
	HWCFG2	I		Hardware Configuration Input 2
	OUT58	O1		OUT58 Line of GPTA0
	OUT58	O2		OUT58 Line of GPTA1
	OUT82	O3		OUT82 Line of LTCA2
B8	P0.3	I/O	A1/ PU	Port 0 General Purpose I/O Line 3
	HWCFG3	I		Hardware Configuration Input 3
	OUT59	O1		OUT59 Line of GPTA0
	OUT59	O2		OUT59 Line of GPTA1
	OUT83	O3		OUT83 Line of LTCA2

Pinning TC1793 Pin Configuration
Table 2 Pin Definitions and Functions (cont'd)

Pin	Symbol	Ctrl.	Type	Function
B7	P0.4	I/O	A1/ PU	Port 0 General Purpose I/O Line 4
	HWCFG4	I		Hardware Configuration Input 4
	OUT60	O1		OUT60 Line of GPTA0
	OUT60	O2		OUT60 Line of GPTA1
	EVTO0	O3		MCDS Output Event 0¹⁾
A6	P0.5	I/O	A1/ PU	Port 0 General Purpose I/O Line 5
	HWCFG5	I		Hardware Configuration Input 5
	OUT61	O1		OUT61 Line of GPTA0
	OUT61	O2		OUT61 Line of GPTA1
	EVTO1	O3		MCDS Output Event 1¹⁾
B6	P0.6	I/O	A2/ PU	Port 0 General Purpose I/O Line 6
	HWCFG6	I		Hardware Configuration Input 6
	OUT62	O1		OUT62 Line of GPTA0
	OUT62	O2		OUT62 Line of GPTA1
	EVTO2	O3		MCDS Output Event 2¹⁾
C8	P0.7	I/O	A1/ PU	Port 0 General Purpose I/O Line 7
	HWCFG7	I		Hardware Configuration Input 7
	OUT63	O1		OUT63 Line of GPTA0
	OUT63	O2		OUT63 Line of GPTA1
	EVTO3	O3		MCDS Output Event 3¹⁾
C7	P0.8	I/O	A1/ PU	Port 0 General Purpose I/O Line 8
	Reserved	O1		-
	Reserved	O2		-
	Reserved	O3		-

Pinning TC1793 Pin Configuration

Table 2 Pin Definitions and Functions (cont'd)

Pin	Symbol	Ctrl.	Type	Function
B5	P0.9	I/O	A1/ PU	Port 0 General Purpose I/O Line 9
	RXDA0	I		E-Ray Channel A Receive Data Input 0 ²⁾
	Reserved	O1		-
	Reserved	O2		-
	Reserved	O3		-
C6	P0.10	I/O	A2/ PU	Port 0 General Purpose I/O Line 10
	TXENA	O1		E-Ray Channel A transmit Data Output enable ²⁾
	Reserved	O2		-
	Reserved	O3		-
D6	P0.11	I/O	A2/ PU	Port 0 General Purpose I/O Line 11
	T5INB	I		GPT120
	T5INA	I		GPT121
	TXENB	O1		E-Ray Channel B transmit Data Output enable ²⁾
	Reserved	O2		-
	Reserved	O3		-
C5	P0.12	I/O	A2/ PU	Port 0 General Purpose I/O Line 12
	T5EUDA	I		GPT120
	T5EUDB	I		GPT121
	TXDB	O1		E-Ray Channel B transmit Data Output ²⁾
	Reserved	O2		-
	Reserved	O3		-

Pinning TC1793 Pin Configuration

Table 2 Pin Definitions and Functions (cont'd)

Pin	Symbol	Ctrl.	Type	Function
D5	P0.13	I/O	A1/ PU	Port 0 General Purpose I/O Line 13
	RXDB0	I		E-Ray Channel B Receive Data Input 0 ²⁾
	T5EUDB	I		GPT120
	T5EUDA	I		GPT121
	Reserved	O1		-
	Reserved	O2		-
	Reserved	O3		-
A5	P0.14	I/O	A2/ PU	Port 0 General Purpose I/O Line 14
	T6INA	I		GPT120
	T6INB	I		GPT121
	TXDA	O1		E-Ray Channel A transmit Data Output ²⁾
	Reserved	O2		-
	Reserved	O3		-
D4	P0.15	I/O	A1/ PU	Port 0 General Purpose I/O Line 15
	Reserved	O1		-
	Reserved	O2		-
	Reserved	O3		-
Port 1				
P3	P1.0	I/O	A2/ PU	Port 1 General Purpose I/O Line 0
	REQ0	I		External trigger Input 0
	EXTCLK1	O1		External Clock Output 1
	Reserved	O2		-
	Reserved	O3		-

Pinning TC1793 Pin Configuration
Table 2 Pin Definitions and Functions (cont'd)

Pin	Symbol	Ctrl.	Type	Function
P2	P1.1	I/O	A1/ PU	Port 1 General Purpose I/O Line 1
	REQ1	I		External trigger Input 1
	CC60INA	I		CCU60
	CC60INB	I		CCU61
	CC60	O1		CCU60
	Reserved	O2		-
	Reserved	O3		-
P1	P1.2	I/O	A1/ PU	Port 1 General Purpose I/O Line 2
	REQ2	I		External trigger Input 2
	Reserved	O1		-
	Reserved	O2		-
	Reserved	O3		-
N1	P1.3	I/O	A1/ PU	Port 1 General Purpose I/O Line 3
	REQ3	I		External trigger Input 3
	TREADY0B	I		MLI0 transmit Channel ready Input B
	Reserved	O1		-
	Reserved	O2		-
	Reserved	O3		-
N4	P1.4	I/O	A2/ PU	Port 1 General Purpose I/O Line 4
	TCLK0	O1		MLI0 transmit Channel Clock Output
	Reserved	O2		-
	Reserved	O3		-

Pinning TC1793 Pin Configuration

Table 2 Pin Definitions and Functions (cont'd)

Pin	Symbol	Ctrl.	Type	Function
M4	P1.5	I/O	A1/ PU	Port 1 General Purpose I/O Line 35
	TREADY0A	I		MLI0 transmit Channel ready Input A
	Reserved	O1		-
	Reserved	O2		-
	Reserved	O3		-
N3	P1.6	I/O	A2/ PU	Port 1 General Purpose I/O Line 6
	TVALID0A	O1		MLI0 transmit Channel valid Output A
	SLSO10	O2		SSC1 Slave Select Output Line 10
	COU60	O3		CCU60
N2	P1.7	I/O	A2/ PU	Port 1 General Purpose I/O Line 7
	CC61INB	I		CCU60
	CC61INA	I		CCU61
	TData0	O1		MLI0 transmit Channel Data Output
	CC61	O2		CCU61
	T3OUT	O3		GPT120
M3	P1.8	I/O	A1/ PU	Port 1 General Purpose I/O Line 8
	RCLK0A	I		MLI0 Receive Channel Clock Input A
	OUT64	O1		OUT64 Line of GPTA0
	OUT64	O2		OUT64 Line of GPTA1
	OUT88	O3		OUT88 Line of LTCA2
M2	P1.9	I/O	A2/ PU	Port 1 General Purpose I/O Line 9
	RREADY0A	O1		MLI0 Receive Channel ready Output A
	SLSO11	O2		SSC1 Slave Select Output Line 11
	OUT65	O3		OUT65 Line of GPTA0

Pinning TC1793 Pin Configuration
Table 2 Pin Definitions and Functions (cont'd)

Pin	Symbol	Ctrl.	Type	Function
M1	P1.10	I/O	A1/ PU	Port 1 General Purpose I/O Line 10
	RVALID0A	I		MLI0 Receive Channel valid Input A
	OUT66	O1		OUT66 Line of GPTA0
	OUT66	O2		OUT66 Line of GPTA1
	OUT90	O3		OUT90 Line of LTCA2
L4	P1.11	I/O	A1/ PU	Port 1 General Purpose I/O Line 11
	RDATA0A	I		MLI0 Receive Channel Data Input A
	SLSI3	I		SSC3 Input
	OUT67	O1		OUT67 Line of GPTA0
	OUT67	O2		OUT67 Line of GPTA1
	OUT91	O3		OUT91 Line of LTCA2
P4	P1.12	I/O	A2/ PU	Port 1 General Purpose I/O Line 12
	EXTCLK0	O1		External Clock Output 0
	OUT68	O2		OUT68 Line of GPTA0
	OUT68	O3		OUT68 Line of GPTA1
L3	P1.13	I/O	A1/ PU	Port 1 General Purpose I/O Line 13
	RCLK0B	I		MLI0 Receive Channel Clock Input B
	OUT69	O1		OUT69 Line of GPTA0
	OUT69	O2		OUT69 Line of GPTA1
	OUT93	O3		OUT93 Line of LTCA2
L2	P1.14	I/O	A1/ PU	Port 1 General Purpose I/O Line 14
	RVALID0B	I		MLI0 Receive Channel valid Input B
	OUT70	O1		OUT70 Line of GPTA0
	OUT70	O2		OUT70 Line of GPTA1
	OUT94	O3		OUT94 Line of LTCA2

Pinning TC1793 Pin Configuration

Table 2 Pin Definitions and Functions (cont'd)

Pin	Symbol	Ctrl.	Type	Function
L1	P1.15	I/O	A1/ PU	Port 1 General Purpose I/O Line 15
	RDATA0B	I		MLI0 Receive Channel Data Input B
	OUT71	O1		OUT71 Line of GPTA0
	OUT71	O2		OUT71 Line of GPTA1
	OUT95	O3		OUT95 Line of LTCA2
Port 2				
D3	P2.2	I/O	A1+/ PU	Port 2 General Purpose I/O Line 2
	SLSO02	O1		SSC0 Slave Select Output Line 2
	SLSO12	O2		SSC1 Slave Select Output Line 12
	SLSO02 AND SLSO12	O3		SSC0 & SSC1 Slave Select Output Line 2 AND Slave Select Output Line 12
D2	P2.3	I/O	A1+/ PU	Port 2 General Purpose I/O Line 3
	SLSO03	O1		SSC0 Slave Select Output Line 3
	SLSO13	O2		SSC1 Slave Select Output Line 13
	SLSO03 AND SLSO13	O3		SSC0 & SSC1 Slave Select Output Line 3 AND Slave Select Output Line 13
D1	P2.4	I/O	A1+/ PU	Port 2 General Purpose I/O Line 4
	SLSO04	O1		SSC0 Slave Select Output Line 4
	SLSO14	O2		SSC1 Slave Select Output Line 14
	SLSO04 AND SLSO14	O3		SSC0 & SSC1 Slave Select Output Line 4 AND Slave Select Output Line 14

Pinning TC1793 Pin Configuration

Table 2 Pin Definitions and Functions (cont'd)

Pin	Symbol	Ctrl.	Type	Function
C1	P2.5	I/O	A1+/ PU	Port 2 General Purpose I/O Line 5
	SLSO05	O1		SSC0 Slave Select Output Line 5
	SLSO15	O2		SSC1 Slave Select Output Line 15
	SLSO05 AND SLSO15	O3		SSC0 & SSC1 Slave Select Output Line 5 AND Slave Select Output Line 15
B1	P2.6	I/O	A1+/ PU	Port 2 General Purpose I/O Line 6
	SLSO06	O1		SSC0 Slave Select Output Line 6
	SLSO16	O2		SSC1 Slave Select Output Line 16
	SLSO06 AND SLSO16	O3		SSC0 & SSC1 Slave Select Output Line 6 AND Slave Select Output Line 16
B2	P2.7	I/O	A1+/ PU	Port 2 General Purpose I/O Line 7
	SLSO07	O1		SSC0 Slave Select Output Line 7
	SLSO17	O2		SSC1 Slave Select Output Line 17
	SLSO07 AND SLSO17	O3		SSC0 & SSC1 Slave Select Output Line 7AND Slave Select Output Line 17

Pinning TC1793 Pin Configuration

Table 2 Pin Definitions and Functions (cont'd)

Pin	Symbol	Ctrl.	Type	Function
C2	P2.8	I/O	A1/ PU	Port 2 General Purpose I/O Line 8
	IN0	I		IN0 Line of GPTA0
	IN0	I		IN0 Line of GPTA1
	IN0	I		IN0 Line of LTCA2
	CCPOS0A	I		CCU62
	T12HRB	I		CCU63
	T3INB	I		GPT120
	T3INA	I		GPT121
	OUT0	O1		OUT0 Line of GPTA0
	OUT0	O2		OUT0 Line of GPTA1
	OUT0	O3		OUT0 Line of LTCA2
A2	P2.9	I/O	A1/ PU	Port 2 General Purpose I/O Line 9
	IN1	I		IN1 Line of GPTA0
	IN1	I		IN1 Line of GPTA1
	IN1	I		IN1 Line of LTCA2
	OUT1	O1		OUT1 Line of GPTA0
	OUT1	O2		OUT1 Line of GPTA1
	OUT1	O3		OUT1 Line of LTCA2

Pinning TC1793 Pin Configuration

Table 2 Pin Definitions and Functions (cont'd)

Pin	Symbol	Ctrl.	Type	Function
B3	P2.10	I/O	A1/ PU	Port 2 General Purpose I/O Line 10
	IN2	I		IN2 Line of GPTA0
	IN2	I		IN2 Line of GPTA1
	IN2	I		IN2 Line of LTCA2
	T12HRE	I		CCU60
	CC61INC	I		CCU60
	CTRAPA	I		CCU61
	CTRAPB	I		CCU63
	CC60INC	I		CCU61
	OUT2	O1		OUT2 Line of GPTA0
	OUT2	O2		OUT2 Line of GPTA1
	OUT2	O3		OUT2 Line of LTCA2
C3	P2.11	I/O	A1/ PU	Port 2 General Purpose I/O Line 11
	IN3	I		IN3 Line of GPTA0
	IN3	I		IN3 Line of GPTA1
	IN3	I		IN3 Line of LTCA2
	OUT3	O1		OUT3 Line of GPTA0
	OUT3	O2		OUT3 Line of GPTA1
	OUT3	O3		OUT3 Line of LTCA2

Pinning TC1793 Pin Configuration

Table 2 Pin Definitions and Functions (cont'd)

Pin	Symbol	Ctrl.	Type	Function
C4	P2.12	I/O	A1/ PU	Port 2 General Purpose I/O Line 12
	IN4	I		IN4 Line of GPTA0
	IN4	I		IN4 Line of GPTA1
	IN4	I		IN4 Line of LTCA2
	T12HRB	I		CCU62
	CCPOS0A	I		CCU63
	T2INB	I		GPT120
	T2INA	I		GPT121
	OUT4	O1		OUT4 Line of GPTA0
	OUT4	O2		OUT4 Line of GPTA1
	OUT4	O3		OUT4 Line of LTCA2
A3	P2.13	I/O	A1/ PU	Port 2 General Purpose I/O Line 13
	IN5	I		IN5 Line of GPTA0
	IN5	I		IN5 Line of GPTA1
	IN5	I		IN5 Line of LTCA2
	OUT5	O1		OUT5 Line of GPTA0
	OUT5	O2		OUT5 Line of GPTA1
	OUT5	O3		OUT5 Line of LTCA2

Pinning TC1793 Pin Configuration

Table 2 Pin Definitions and Functions (cont'd)

Pin	Symbol	Ctrl.	Type	Function
B4	P2.14	I/O	A1/ PU	Port 2 General Purpose I/O Line 14
	IN6	I		IN6 Line of GPTA0
	IN6	I		IN6 Line of GPTA1
	IN6	I		IN6 Line of LTCA2
	CCPOS0A	I		CCU60
	T12HRB	I		CCU61
	T3INA	I		GPT120
	T3INB	I		GPT121
	OUT6	O1		OUT6 Line of GPTA0
	OUT6	O2		OUT6 Line of GPTA1
	OUT6	O3		OUT6 Line of LTCA2
A4	P2.15	I/O	A1/ PU	Port 2 General Purpose I/O Line 15
	IN7	I		IN7 Line of GPTA0
	IN7	I		IN7 Line of GPTA1
	IN7	I		IN7 Line of LTCA2
	OUT7	O1		OUT7 Line of GPTA0
	OUT7	O2		OUT7 Line of GPTA1
	OUT7	O3		OUT7 Line of LTCA2
Port 3				

Pinning TC1793 Pin Configuration

Table 2 Pin Definitions and Functions (cont'd)

Pin	Symbol	Ctrl.	Type	Function
B12	P3.0	I/O	A1/ PU	Port 3 General Purpose I/O Line 0
	IN8	I		IN8 Line of GPTA0
	IN8	I		IN8 Line of GPTA1
	IN8	I		IN8 Line of LTCA2
	CTRAPA	I		CCU62
	CTRAPB	I		CCU61
	CC60INC	I		CCU62
	T12HRE	I		CCU63
	CC61INC	I		CCU63
	T5INA	I		GPT120
	T5INB	I		GPT121
	OUT8	O1		OUT8 Line of GPTA0
	OUT8	O2		OUT8 Line of GPTA1
OUT8	O3	OUT8 Line of LTCA2		
A12	P3.1	I/O	A1/ PU	Port 3 General Purpose I/O Line 1
	IN9	I		IN9 Line of GPTA0
	IN9	I		IN9 Line of GPTA1
	IN9	I		IN9 Line of LTCA2
	OUT9	O1		OUT9 Line of GPTA0
	OUT9	O2		OUT9 Line of GPTA1
	OUT9	O3		OUT9 Line of LTCA2

Pinning TC1793 Pin Configuration

Table 2 Pin Definitions and Functions (cont'd)

Pin	Symbol	Ctrl.	Type	Function
C13	P3.2	I/O	A1/ PU	Port 3 General Purpose I/O Line 2
	IN10	I		IN10 Line of GPTA0
	IN10	I		IN10 Line of GPTA1
	IN10	I		IN10 Line of LTCA2
	T13HRE	I		CCU63
	OUT10	O1		OUT10 Line of GPTA0
	OUT10	O2		OUT10 Line of GPTA1
	OUT10	O3		OUT10 Line of LTCA2
B11	P3.3	I/O	A1/ PU	Port 3 General Purpose I/O Line 3
	IN11	I		IN11 Line of GPTA0
	IN11	I		IN11 Line of GPTA1
	IN11	I		IN11 Line of LTCA2
	OUT11	O1		OUT11 Line of GPTA0
	OUT11	O2		OUT11 Line of GPTA1
	OUT11	O3		OUT11 Line of LTCA2

Pinning TC1793 Pin Configuration

Table 2 Pin Definitions and Functions (cont'd)

Pin	Symbol	Ctrl.	Type	Function
C12	P3.4	I/O	A1/ PU	Port 3 General Purpose I/O Line 4
	IN12	I		IN12 Line of GPTA0
	IN12	I		IN12 Line of GPTA1
	IN12	I		IN12 Line of LTCA2
	T12HRE	I		CCU62
	CC61INC	I		CCU62
	CTRAPA	I		CCU63
	CTRAPB	I		CCU60
	CC60INC	I		CCU63
	OUT12	O1		OUT12 Line of GPTA0
	OUT12	O2		OUT12 Line of GPTA1
	OUT12	O3		OUT12 Line of LTCA2
A11	P3.5	I/O	A1/ PU	Port 3 General Purpose I/O Line 5
	IN13	I		IN13 Line of GPTA0
	IN13	I		IN13 Line of GPTA1
	IN13	I		IN13 Line of LTCA2
	OUT13	O1		OUT13 Line of GPTA0
	OUT13	O2		OUT13 Line of GPTA1
	OUT13	O3		OUT13 Line of LTCA2

Pinning TC1793 Pin Configuration

Table 2 Pin Definitions and Functions (cont'd)

Pin	Symbol	Ctrl.	Type	Function
B10	P3.6	I/O	A1/ PU	Port 3 General Purpose I/O Line 6
	IN14	I		IN14 Line of GPTA0
	IN14	I		IN14 Line of GPTA1
	IN14	I		IN14 Line of LTCA2
	T13HRE	I		CCU62
	T6EUDB	I		GPT120
	T6EUDA	I		GPT121
	OUT14	O1		OUT14 Line of GPTA0
	OUT14	O2		OUT14 Line of GPTA1
	OUT14	O3		OUT14 Line of LTCA2
C9	P3.7	I/O	A1/ PU	Port 3 General Purpose I/O Line 7
	IN15	I		IN15 Line of GPTA0
	IN15	I		IN15 Line of GPTA1
	IN15	I		IN15 Line of LTCA2
	OUT15	O1		OUT15 Line of GPTA0
	OUT15	O2		OUT15 Line of GPTA1
	OUT15	O3		OUT15 Line of LTCA2
D10	P3.8	I/O	A1/ PU	Port 3 General Purpose I/O Line 8
	IN16	I		IN16 Line of GPTA0
	IN16	I		IN16 Line of GPTA1
	IN16	I		IN16 Line of LTCA2
	T13HRE	I		CCU61
	OUT16	O1		OUT16 Line of GPTA0
	OUT16	O2		OUT16 Line of GPTA1
	OUT16	O3		OUT16 Line of LTCA2

Pinning TC1793 Pin Configuration

Table 2 Pin Definitions and Functions (cont'd)

Pin	Symbol	Ctrl.	Type	Function
C11	P3.9	I/O	A1/ PU	Port 3 General Purpose I/O Line 9
	IN17	I		IN17 Line of GPTA0
	IN17	I		IN17 Line of GPTA1
	IN17	I		IN17 Line of LTCA2
	OUT17	O1		OUT17 Line of GPTA0
	OUT17	O2		OUT17 Line of GPTA1
	OUT17	O3		OUT17 Line of LTCA2
C10	P3.10	I/O	A1+/ PU	Port 3 General Purpose I/O Line 10
	IN18	I		IN18 Line of GPTA0
	IN18	I		IN18 Line of GPTA1
	IN18	I		IN18 Line of LTCA2
	CCPOS1A	I		CCU62
	T13HRB	I		CCU63
	T3EADB	I		GPT120
	T3EUDA	I		GPT121
	OUT18	O1		OUT18 Line of GPTA0
	OUT18	O2		OUT18 Line of GPTA1
	OUT18	O3		OUT18 Line of LTCA2
D13	P3.11	I/O	A1/ PU	Port 3 General Purpose I/O Line 11
	IN19	I		IN19 Line of GPTA0
	IN19	I		IN19 Line of GPTA1
	IN19	I		IN19 Line of LTCA2
	OUT19	O1		OUT19 Line of GPTA0
	OUT19	O2		OUT19 Line of GPTA1
	OUT19	O3		OUT19 Line of LTCA2

Pinning TC1793 Pin Configuration

Table 2 Pin Definitions and Functions (cont'd)

Pin	Symbol	Ctrl.	Type	Function
D11	P3.12	I/O	A1/ PU	Port 3 General Purpose I/O Line 12
	IN20	I		IN20 Line of GPTA0
	IN20	I		IN20 Line of GPTA1
	IN20	I		IN20 Line of LTCA2
	CCPOS2A	I		CCU62
	T12HRC	I		CCU63
	T13HRC	I		CCU63
	T4INB	I		GPT120
	T4INA	I		GPT121
	OUT20	O1		OUT20 Line of GPTA0
	OUT20	O2		OUT20 Line of GPTA1
	OUT20	O3		OUT20 Line of LTCA2
D12	P3.13	I/O	A1/ PU	Port 3 General Purpose I/O Line 13
	IN21	I		IN21 Line of GPTA0
	IN21	I		IN21 Line of GPTA1
	IN21	I		IN21 Line of LTCA2
	OUT21	O1		OUT21 Line of GPTA0
	OUT21	O2		OUT21 Line of GPTA1
	OUT21	O3		OUT21 Line of LTCA2

Pinning TC1793 Pin Configuration

Table 2 Pin Definitions and Functions (cont'd)

Pin	Symbol	Ctrl.	Type	Function
A10	P3.14	I/O	A1/ PU	Port 3 General Purpose I/O Line 14
	IN22	I		IN22 Line of GPTA0
	IN22	I		IN22 Line of GPTA1
	IN22	I		IN22 Line of LTCA2
	T13HRE	I		CCU63
	OUT22	O1		OUT22 Line of GPTA0
	OUT22	O2		OUT22 Line of GPTA1
	OUT22	O3		OUT22 Line of LTCA2
B9	P3.15	I/O	A1/ PU	Port 3 General Purpose I/O Line 15
	IN23	I		IN23 Line of GPTA0
	IN23	I		IN23 Line of GPTA1
	IN23	I		IN23 Line of LTCA2
	OUT23	O1		OUT23 Line of GPTA0
	OUT23	O2		OUT23 Line of GPTA1
	OUT23	O3		OUT23 Line of LTCA2
Port 4				
AD10	P4.0	I/O	A1+/ PU	Port 4 General Purpose I/O Line 0
	IN24	I		IN24 Line of GPTA0
	IN24	I		IN24 Line of GPTA1
	IN24	I		IN24 Line of LTCA2
	MRST2A	I		SSC2 Master Receive Input A (Master Mode)
	OUT24	O1		OUT24 Line of GPTA0
	OUT24	O2		OUT24 Line of GPTA1
	MRST2	O3		SSC2 Slave Transmit Output (Slave Mode)

Pinning TC1793 Pin Configuration

Table 2 Pin Definitions and Functions (cont'd)

Pin	Symbol	Ctrl.	Type	Function
AE10	P4.1	I/O	A1+/ PU	Port 4 General Purpose I/O Line 1
	IN25	I		IN25 Line of GPTA0
	IN25	I		IN25 Line of GPTA1
	IN25	I		IN25 Line of LTCA2
	MTSR2A	I		SSC2 Slave Receive Input A (Slave Mode)
	MRSTG2A	I		SSC Guardian 2 Master Receive Input A (Master Mode)
	OUT25	O1		OUT25 Line of GPTA0
	OUT25	O2		OUT25 Line of GPTA1
	MTSR2	O3		SSC2 Master Transmit Output (Master Mode) ³⁾
AD11	P4.2	I/O	A1+/ PU	Port 4 General Purpose I/O Line 2
	IN26	I		IN26 Line of GPTA0
	IN26	I		IN26 Line of GPTA1
	IN26	I		IN26 Line of LTCA2
	SCLK2	I		SSC2 Input
	OUT26	O1		OUT26 Line of GPTA0
	OUT26	O2		OUT26 Line of GPTA1
	SCLK2	O3		SSC2 Output
AE11	P4.3	I/O	A1+/ PU	Port 4 General Purpose I/O Line 3
	IN27	I		IN27 Line of GPTA0
	IN27	I		IN27 Line of GPTA1
	IN27	I		IN27 Line of LTCA2
	OUT27	O1		OUT27 Line of GPTA0
	OUT27	O2		OUT27 Line of GPTA1
	SLSO20	O3		SSC2 Output

Pinning TC1793 Pin Configuration

Table 2 Pin Definitions and Functions (cont'd)

Pin	Symbol	Ctrl.	Type	Function
AC12	P4.4	I/O	A1+/ PU	Port 4 General Purpose I/O Line 4
	IN28	I		IN28 Line of GPTA0
	IN28	I		IN28 Line of GPTA1
	IN28	I		IN28 Line of LTCA2
	OUT28	O1		OUT28 Line of GPTA0
	OUT28	O2		OUT28 Line of GPTA1
	SLSO21	O3		SSC2 Output
AD12	P4.5	I/O	A1+/ PU	Port 4 General Purpose I/O Line 5
	IN29	I		IN29 Line of GPTA0
	IN29	I		IN29 Line of GPTA1
	IN29	I		IN29 Line of LTCA2
	OUT29	O1		OUT29 Line of GPTA0
	OUT29	O2		OUT29 Line of GPTA1
	SLSO22	O3		SSC2 Output
AF10	P4.6	I/O	A1+/ PU	Port 4 General Purpose I/O Line 6
	IN30	I		IN30 Line of GPTA0
	IN30	I		IN30 Line of GPTA1
	IN30	I		IN30 Line of LTCA2
	OUT30	O1		OUT30 Line of GPTA0
	OUT30	O2		OUT30 Line of GPTA1
	SLSO23	O3		SSC2 Output

Pinning TC1793 Pin Configuration

Table 2 Pin Definitions and Functions (cont'd)

Pin	Symbol	Ctrl.	Type	Function
AE12	P4.7	I/O	A1+/ PU	Port 4 General Purpose I/O Line 7
	IN31	I		IN31 Line of GPTA0
	IN31	I		IN31 Line of GPTA1
	IN31	I		IN31 Line of LTCA2
	T6INB	I		GPT120
	T6INA	I		GPT121
	OUT31	O1		OUT31 Line of GPTA0
	OUT31	O2		OUT31 Line of GPTA1
	SLSO24	O3		SSC2 Output
AC13	P4.8	I/O	A1/ PU	Port 4 General Purpose I/O Line 8
	IN32	I		IN32 Line of GPTA0
	IN32	I		IN32 Line of GPTA1
	CCPOS1A	I		CCU60
	T13HRB	I		CCU61
	T3EUDA	I		GPT120
	T3EUDB	I		GPT121
	OUT32	O1		OUT32 Line of GPTA0
	OUT32	O2		OUT32 Line of GPTA1
	OUT0	O3		OUT0 Line of LTCA2

Pinning TC1793 Pin Configuration

Table 2 Pin Definitions and Functions (cont'd)

Pin	Symbol	Ctrl.	Type	Function
AB19	P4.9	I/O	A1/ PU	Port 4 General Purpose I/O Line 9
	IN33	I		IN33 Line of GPTA0
	IN33	I		IN33 Line of GPTA1
	CCPOS2A	I		CCU60
	T12HRC	I		CCU61
	T13HRC	I		CCU61
	T4INA	I		GPT120
	T4INB	I		GPT121
	$\overline{\text{SLSI2}}$	I		SSC2
	OUT33	O1		OUT33 Line of GPTA0
	OUT33	O2		OUT33 Line of GPTA1
	OUT1	O3		OUT1 Line of LTCA2
AF12	P4.10	I/O	A1/ PU	Port 4 General Purpose I/O Line 10
	IN34	I		IN34 Line of GPTA0
	IN34	I		IN34 Line of GPTA1
	T12HRB	I		CCU60
	CCPOS0A	I		CCU61
	T2INA	I		GPT120
	T2INB	I		GPT121
	OUT34	O1		OUT34 Line of GPTA0
	OUT34	O2		OUT34 Line of GPTA1
	OUT2	O3		OUT2 Line of LTCA2

Pinning TC1793 Pin Configuration

Table 2 Pin Definitions and Functions (cont'd)

Pin	Symbol	Ctrl.	Type	Function
AD13	P4.11	I/O	A1/ PU	Port 4 General Purpose I/O Line 11
	IN35	I		IN35 Line of GPTA0
	IN35	I		IN35 Line of GPTA1
	OUT35	O1		OUT35 Line of GPTA0
	OUT35	O2		OUT35 Line of GPTA1
	OUT3	O3		OUT3 Line of LTCA2
AC14	P4.12	I/O	A1/ PU	Port 4 General Purpose I/O Line 12
	IN36	I		IN36 Line of GPTA0
	IN36	I		IN36 Line of GPTA1
	T13HRB	I		CCU60
	CCPOS1A	I		CCU61
	T2EUDA	I		GPT120
	T2EADB	I		GPT121
	OUT36	O1		OUT36 Line of GPTA0
	OUT36	O2		OUT36 Line of GPTA1
	OUT4	O3		OUT4 Line of LTCA2
AE13	P4.13	I/O	A1/ PU	Port 4 General Purpose I/O Line 13
	IN37	I		IN37 Line of GPTA0
	IN37	I		IN37 Line of GPTA1
	OUT37	O1		OUT37 Line of GPTA0
	OUT37	O2		OUT37 Line of GPTA1
	OUT5	O3		OUT5 Line of LTCA2

Pinning TC1793 Pin Configuration

Table 2 Pin Definitions and Functions (cont'd)

Pin	Symbol	Ctrl.	Type	Function
AF13	P4.14	I/O	A1/ PU	Port 4 General Purpose I/O Line 14
	IN38	I		IN38 Line of GPTA0
	IN38	I		IN38 Line of GPTA1
	T12HRC	I		CCU60
	T13HRC	I		CCU60
	CCPOS2A	I		CCU61
	T4EUDA	I		GPT120
	T4EUDB	I		GPT121
	OUT38	O1		OUT38 Line of GPTA0
	OUT38	O2		OUT38 Line of GPTA1
OUT6	O3	OUT6 Line of LTCA2		
AD14	P4.15	I/O	A1/ PU	Port 4 General Purpose I/O Line 15
	IN39	I		IN39 Line of GPTA0
	IN39	I		IN39 Line of GPTA1
	OUT39	O1		OUT39 Line of GPTA0
	OUT39	O2		OUT39 Line of GPTA1
	OUT7	O3		OUT7 Line of LTCA2
Port 5				
B13	P5.0	I/O	A1+/ PU	Port 5 General Purpose I/O Line 0
	RXD0A	I		ASC0 Receiver Input/Output A
	T6EUDA	I		GPT120
	T6EUDB	I		GPT121
	RXD0A	O1		ASC0 Receiver Input/Output A
	OUT72	O2		OUT72 Line of GPTA0
	OUT72	O3		OUT72 Line of GPTA1

Pinning TC1793 Pin Configuration
Table 2 Pin Definitions and Functions (cont'd)

Pin	Symbol	Ctrl.	Type	Function
A13	P5.1	I/O	A1+/ PU	Port 5 General Purpose I/O Line 1
	TXD0	O1		ASC0 Transmitter Output A
	OUT73	O2		OUT73 Line of GPTA0
	OUT73	O3		OUT73 Line of GPTA1
A14	P5.2	I/O	A2/ PU	Port 5 General Purpose I/O Line 2
	RXD1A	I		ASC1 Receiver Input/Output A
	RXD1A	O1		ASC1 Receiver Input/Output A
	OUT74	O2		OUT74 Line of GPTA0
	OUT74	O3		OUT74 Line of GPTA1
B14	P5.3	I/O	A1+/ PU	Port 5 General Purpose I/O Line 3
	TXD1	O1		ASC1 Transmitter Output A
	OUT75	O2		OUT75 Line of GPTA0
	OUT75	O3		OUT75 Line of GPTA1
C15	P5.4	I/O	A2/ PU	Port 5 General Purpose I/O Line 4
	T13HRB	I		CCU62
	CCPOS1A	I		CCU63
	T2EADB	I		GPT120
	T2EUDA	I		GPT121
	EN00	O1		MSC0 Device Select Output 0
	RREADY0B	O2		MLI0 Receive Channel ready Output B
	OUT76	O3		OUT76 Line of GPTA0

Pinning TC1793 Pin Configuration
Table 2 Pin Definitions and Functions (cont'd)

Pin	Symbol	Ctrl.	Type	Function
C14	P5.5	I/O	A1+/ PU	Port 5 General Purpose I/O Line 5
	SDI0	I		MSC0 Serial Data Input
	T12HRC	I		CCU62
	T13HRC	I		CCU62
	CCPOS2A	I		CCU63
	T4EUDB	I		GPT120
	T4EUDA	I		GPT121
	OUT77	O1		OUT77 Line of GPTA0
	OUT77	O2		OUT77 Line of GPTA1
OUT101	O3	OUT101 Line of LTCA2		
B15	P5.6	I/O	A2/ PU	Port 5 General Purpose I/O Line 6
	CC60INA	I		CCU62
	CC60INB	I		CCU63
	EN10	O1		MSC1 Device Select Output 0
	TVALID0B	O2		MLI0 transmit Channel valid Output B
	CC60	O3		CCU62
A15	P5.7	I/O	A1+/ PU	Port 5 General Purpose I/O Line 7
	SDI1	I		MSC1 Serial Data Input
	CC61INA	I		CCU62
	CC61INB	I		CCU63
	OUT79	O1		OUT79 Line of GPTA0
	OUT79	O2		OUT79 Line of GPTA1
	CC61	O3		CCU62

Pinning TC1793 Pin Configuration

Table 2 Pin Definitions and Functions (cont'd)

Pin	Symbol	Ctrl.	Type	Function
D17	P5.8	I/O	F/ PU	Port 5 General Purpose I/O Line 8
	CC62INA	I		CCU62
	CC62INB	I		CCU63
	SON0	O1		MSC0 Differential Driver Serial Data Output Negative
	OUT80	O2		OUT80 Line of GPTA0
	CC62	O3		CCU62
C16	P5.9	I/O	F/ PU	Port 5 General Purpose I/O Line 9
	SOP0A	O1		MSC0 Differential Driver Serial Data Output Positive A
	OUT81	O2		OUT81 Line of GPTA0
	COU60	O3		CCU62
C17	P5.10	I/O	F/ PU	Port 5 General Purpose I/O Line 10
	FCLN0	O1		MSC0 Differential Driver Clock Output Negative
	OUT82	O2		OUT82 Line of GPTA0
	COU61	O3		CCU62
C18	P5.11	I/O	F/ PU	Port 5 General Purpose I/O Line 11
	FCLP0A	O1		MSC0 Differential Driver Clock Output Positive A
	OUT83	O2		OUT83 Line of GPTA0
	COU62	O3		CCU62
A16	P5.12	I/O	F/ PU	Port 5 General Purpose I/O Line 12
	SON1	O1		MSC1 Differential Driver Serial Data Output Negative
	OUT84	O2		OUT84 Line of GPTA0
	OUT84	O3		OUT84 Line of GPTA1

Pinning TC1793 Pin Configuration

Table 2 Pin Definitions and Functions (cont'd)

Pin	Symbol	Ctrl.	Type	Function
B16	P5.13	I/O	F/ PU	Port 5 General Purpose I/O Line 13
	SOP1A	O1		MSC1 Differential Driver Serial Data Output Positive A
	OUT85	O2		OUT85 Line of GPTA0
	OUT85	O3		OUT85 Line of GPTA1
B17	P5.14	I/O	F/ PU	Port 5 General Purpose I/O Line 14
	FCLN1	O1		MSC1 Differential Driver Clock Output Negative
	OUT86	O2		OUT86 Line of GPTA0
	OUT86	O3		OUT86 Line of GPTA1
A17	P5.15	I/O	F/ PU	Port 5 General Purpose I/O Line 15
	FCLNP1A	O1		MSC1 Differential Driver Clock Output Positive A
	OUT87	O2		OUT87 Line of GPTA0
	OUT87	O3		OUT87 Line of GPTA1
Port 6				
F3	P6.4	I/O	A1+/ PU	Port 6 General Purpose I/O Line 4
	MTSR1	I		SSC1 Slave Receive Input (Slave Mode)
	MRSTG1	I		SSC Guardian 1 Master Receive Input (Master Mode)
	MTSR1	O1		SSC1 Master Transmit Output (Master Mode)³⁾
	Reserved	O2		-
	Reserved	O3		-

Pinning TC1793 Pin Configuration

Table 2 Pin Definitions and Functions (cont'd)

Pin	Symbol	Ctrl.	Type	Function
G4	P6.5	I/O	A1+/ PU	Port 6 General Purpose I/O Line 5
	MRST1	I		SSC1 Master Receive Input (Master Mode)
	MRST1	O1		SSC1 Slave Transmit Output (Slave Mode)
	Reserved	O2		-
	Reserved	O3		-
E3	P6.6	I/O	A1+/ PU	Port 6 General Purpose I/O Line 6
	SCLK1	I		SSC1 Clock Input/Output
	SCLK1	O1		SSC1 Clock Input/Output
	Reserved	O2		-
	Reserved	O3		-
G3	P6.7	I/O	A1+/ PU	Port 6 General Purpose I/O Line 7
	SLS11	I		SSC1 slave Select Input
	T6OFL	O1		GPT120
	Reserved	O2		-
	Reserved	O3		-
F4	P6.8	I/O	A2/ PU	Port 6 General Purpose I/O Line 8
	RXDCAN0	I		CAN Node 0 Receiver Input 0 CAN Node 3 Receiver Input 1
	RXD0B	I		ASC0 Receiver Input/Output B
	CAPINB	I		GPT120
	CAPINA	I		GPT121
	Reserved	O1		-
	RXD0B	O2		ASC0 Receiver Input/Output B
	Reserved	O3		-

Pinning TC1793 Pin Configuration

Table 2 Pin Definitions and Functions (cont'd)

Pin	Symbol	Ctrl.	Type	Function
E4	P6.9	I/O	A2/ PU	Port 6 General Purpose I/O Line 9
	TXDCAN0	O1		CAN Node 0 Transmitter Output
	TXD0	O2		ASC0 Transmitter Output B
	T60FL	O3		GPT120
F2	P6.10	I/O	A2/ PU	Port 6 General Purpose I/O Line 10
	RXDCAN1	I		CAN Node 1 Receiver Input 0 CAN Node 0 Receiver Input 1
	RXD1B	I		ASC1 Receiver Input/Output B
	Reserved	O1		-
	RXD1B	O2		ASC1 Receiver Input/Output B
	TXENA	O3		E-Ray Channel A transmit Data Output enable ²⁾
E2	P6.11	I/O	A2/ PU	Port 6 General Purpose I/O Line 11
	TXDCAN1	O1		CAN Node 1 Transmitter Output
	TXD1	O2		ASC1 Transmitter Output B
	TXENB	O3		E-Ray Channel B transmit Data Output enable ²⁾
E1	P6.12	I/O	A1/ PU	Port 6 General Purpose I/O Line 12
	RXDCAN2	I		CAN Node 2 Receiver Input 0 CAN Node 1 Receiver Input 1
	RXDA1	I		E-Ray Channel A Receive Data Input 1 ²⁾
	Reserved	O1		-
	Reserved	O2		-
	COUT61	O3		CCU60

Pinning TC1793 Pin Configuration

Table 2 Pin Definitions and Functions (cont'd)

Pin	Symbol	Ctrl.	Type	Function
G2	P6.13	I/O	A2/ PU	Port 6 General Purpose I/O Line 13
	TXDCAN2	O1		CAN Node 2 Transmitter Output
	TXDA	O2		E-Ray Channel A transmit Data Output ²⁾
	COU62	O3		CCU60
F1	P6.14	I/O	A1/ PU	Port 6 General Purpose I/O Line 14
	RXDCAN3	I		CAN Node 3 Receiver Input 0 CAN Node 2 Receiver Input 1
	RXDB1	I		E-Ray Channel B Receive Data Input 1 ²⁾
	Reserved	O1		-
	Reserved	O2		-
	COU63	O3		CCU60
G1	P6.15	I/O	A2/ PU	Port 6 General Purpose I/O Line 15
	CC60INB	I		CCU60
	CC60INA	I		CCU61
	TXDCAN3	O1		CAN Node 3 Transmitter Output
	TXDB	O2		E-Ray Channel B transmit Data Output ²⁾
	CC60	O3		CCU61
Port 7				
R3	P7.0	I/O	A1+/ PU	Port 7 General Purpose I/O Line 0
	MRST3	I		SSC3 Master Receive Input (Slave Mode)
	REQ4	I		External trigger Input 4
	AD2EMUX2	O1		ADC2 external multiplexer Control Output 2
	MRST3	O2		SSC3 Slave Transmit Output (Maste Mode)
	Reserved	O3		-

Pinning TC1793 Pin Configuration

Table 2 Pin Definitions and Functions (cont'd)

Pin	Symbol	Ctrl.	Type	Function
R2	P7.1	I/O	A1+/ PU	Port 7 General Purpose I/O Line 1
	REQ5	I		External trigger Input 5
	MTSR3	I		SSC3 Slave Receive Input (Slave Mode)
	MRSTG3B	I		SSC Guardian 3 Master Receive Input B (Master Mode)
	AD0EMUX2	O1		ADC0 external multiplexer Control Output 2
	MTSR3	O2		SSC3 Master Transmit Output (Master Mode) ³⁾
	Reserved	O3		-
U4	P7.2	I/O	A1+/ PU	Port 7 General Purpose I/O Line 2
	SCLK3	I		SSC3 Input
	AD0EMUX0	O1		ADC0 external multiplexer Control Output 0
	SCLK3	O2		SSC3 Output
	Reserved	O3		-
U3	P7.3	I/O	A1+/ PU	Port 7 General Purpose I/O Line 3
	AD0EMUX1	O1		ADC0 external multiplexer Control Output 1
	SLSO30	O2		SSC3 Output
	Reserved	O3		-
T3	P7.4	I/O	A1+/ PU	Port 7 General Purpose I/O Line 4
	REQ6	I		External trigger Input 6
	AD2EMUX0	O1		ADC2 external multiplexer Control Output 0
	SLSO31	O2		SSC3 Output
	Reserved	O3		-

Pinning TC1793 Pin Configuration
Table 2 Pin Definitions and Functions (cont'd)

Pin	Symbol	Ctrl.	Type	Function
T2	P7.5	I/O	A1+/ PU	Port 7 General Purpose I/O Line 5
	REQ7	I		External trigger Input 7
	AD2EMUX1	O1		ADC2 external multiplexer Control Output 1
	SLSO32	O2		SSC3 Output
	Reserved	O3		-
T1	P7.6	I/O	A1+/ PU	Port 7 General Purpose I/O Line 6
	AD1EMUX0	O1		ADC1 external multiplexer Control Output 0
	SLSO33	O2		SSC3 Output
	Reserved	O3		-
U2	P7.7	I/O	A1+/ PU	Port 7 General Purpose I/O Line 7
	AD1EMUX1	O1		ADC1 external multiplexer Control Output 1
	SLSO34	O2		SSC3 Output
	Reserved	O3		-
Port 8				
H2	P8.0	I/O	A2/ PU	Port 8 General Purpose I/O Line 0
	IN40	I		IN40 Line of GPTA0
	IN40	I		IN40 Line of GPTA1
	SENT0	I		SENT Digital Input
	OUT40	O1		OUT40 Line of GPTA0
	COUT62	O2		CCU61
	TCLK1	O3		MLI1 transmit Channel Clock Output

Pinning TC1793 Pin Configuration

Table 2 Pin Definitions and Functions (cont'd)

Pin	Symbol	Ctrl.	Type	Function
H1	P8.1	I/O	A1/ PU	Port 8 General Purpose I/O Line 1
	IN41	I		IN41 Line of GPTA0
	IN41	I		IN41 Line of GPTA1
	TREADY1A	I		MLI1 transmit Channel ready Input A
	SENT1	I		SENT Digital Input
	CC61INA	I		CCU60
	CC61INB	I		CCU61
	OUT41	O1		OUT41 Line of GPTA0
	CC61	O2		CCU60
	SENT1	O3		SENT Digital Output
J3	P8.2	I/O	A2/ PU	Port 8 General Purpose I/O Line 2
	IN42	I		IN42 Line of GPTA0
	IN42	I		IN42 Line of GPTA1
	SENT2	I		SENT Digital Input
	CAPINA	I		GPT120
	CAPINB	I		GPT121
	COOUT63	O1		CCU61
	OUT42	O2		OUT42 Line of GPTA1
	TVALID1A	O3		MLI1 transmit Channel valid Output A

Pinning TC1793 Pin Configuration

Table 2 Pin Definitions and Functions (cont'd)

Pin	Symbol	Ctrl.	Type	Function
J2	P8.3	I/O	A2/ PU	Port 8 General Purpose I/O Line 3
	IN43	I		IN43 Line of GPTA0
	IN43	I		IN43 Line of GPTA1
	SENT3	I		SENT Digital Input
	CC62INA	I		CCU60
	CC62INB	I		CCU61
	OUT43	O1		OUT43 Line of GPTA0
	CC62	O2		CCU60
	TDATA1	O3		MLI1 transmit Channel Data Output A
J1	P8.4	I/O	A1/ PU	Port 8 General Purpose I/O Line 4
	IN44	I		IN44 Line of GPTA0
	IN44	I		IN44 Line of GPTA1
	RCLK1A	I		MLI1 Receive Channel Clock Input A
	SENT4	I		SENT Digital Input
	CC62INB	I		CCU60
	CC62INA	I		CCU61
	OUT44	O1		OUT44 Line of GPTA0
	CC62	O2		CCU61
	T3OUT	O3		GPT121

PinningTC1793 Pin Configuration

Table 2 Pin Definitions and Functions (cont'd)

Pin	Symbol	Ctrl.	Type	Function
K2	P8.5	I/O	A2/ PU	Port 8 General Purpose I/O Line 5
	IN45	I		IN45 Line of GPTA0
	IN45	I		IN45 Line of GPTA1
	SENT5	I		SENT Digital Input
	CTRAPA	I		CCU60
	CTRAPB	I		CCU62
	CC60INC	I		CCU60
	T12HRE	I		CCU61
	CC61INC	I		CCU61
	OUT45	O1		OUT45 Line of GPTA0
	OUT45	O2		OUT45 Line of GPTA1
	RREADY1A	O3		MLI1 Receive Channel ready Output A
K3	P8.6	I/O	A1/ PU	Port 8 General Purpose I/O Line 6
	IN46	I		IN46 Line of GPTA0
	IN46	I		IN46 Line of GPTA1
	RVALID1A	I		MLI1 Receive Channel valid Input A
	SENT6	I		SENT Digital Input
	OUT46	O1		OUT46 Line of GPTA0
	COOUT60	O2		CCU61
	T6OUT	O3		GPT120

Pinning TC1793 Pin Configuration

Table 2 Pin Definitions and Functions (cont'd)

Pin	Symbol	Ctrl.	Type	Function
K1	P8.7	I/O	A1/ PU	Port 8 General Purpose I/O Line 7
	IN47	I		IN47 Line of GPTA0
	IN47	I		IN47 Line of GPTA1
	RDATA1A	I		MLI1 Receive Channel Data Input A
	SENT7	I		SENT Digital Input
	OUT47	O1		OUT47 Line of GPTA0
	COU61	O2		CCU61
	T6OUT	O3		GPT121
Port 9				
A19	P9.0	I/O	A2/ PU	Port 9 General Purpose I/O Line 0
	IN48	I		IN48 Line of GPTA0
	IN48	I		IN48 Line of GPTA1
	COU63	O1		CCU62
	OUT48	O2		OUT48 Line of GPTA1
	EN12	O3		MSC1 Device Select Output 2
B19	P9.1	I/O	A2/ PU	Port 9 General Purpose I/O Line 1
	IN49	I		IN49 Line of GPTA0
	IN49	I		IN49 Line of GPTA1
	CC60INB	I		CCU62
	CC60INA	I		CCU63
	CC60	O1		CCU63
	OUT49	O2		OUT49 Line of GPTA1
	EN11	O3		MSC1 Device Select Output 1

Pinning TC1793 Pin Configuration

Table 2 Pin Definitions and Functions (cont'd)

Pin	Symbol	Ctrl.	Type	Function
B20	P9.2	I/O	A2/ PU	Port 9 General Purpose I/O Line 2
	IN50	I		IN50 Line of GPTA0
	IN50	I		IN50 Line of GPTA1
	CC61INB	I		CCU62
	CC61INA	I		CCU63
	CC61	O1		CCU63
	OUT50	O2		OUT50 Line of GPTA1
	SOP1B	O3		MSC1 serial Data Output
A20	P9.3	I/O	A2/ PU	Port 9 General Purpose I/O Line 3
	IN51	I		IN51 Line of GPTA0
	IN51	I		IN51 Line of GPTA1
	CC62INB	I		CCU62
	CC62INA	I		CCU63
	CC62	O1		CCU63
	OUT51	O2		OUT51 Line of GPTA1
	FCLP1B	O3		MSC1 Clock Output
D18	P9.4	I/O	A2/ PU	Port 9 General Purpose I/O Line 4
	IN52	I		IN52 Line of GPTA0
	IN52	I		IN52 Line of GPTA1
	COUT60	O1		CCU63
	OUT52	O2		OUT52 Line of GPTA1
	EN03	O3		MSC0 Device Select Output 3

Pinning TC1793 Pin Configuration

Table 2 Pin Definitions and Functions (cont'd)

Pin	Symbol	Ctrl.	Type	Function
D19	P9.5	I/O	A2/ PU	Port 9 General Purpose I/O Line 5
	IN53	I		IN53 Line of GPTA0
	IN53	I		IN53 Line of GPTA1
	SENT1	I		SENT Digital Input
	COU61	O1		CCU63
	OUT53	O2		OUT53 Line of GPTA1
	EN02	O3		MSC0 Device Select Output 2
C19	P9.6	I/O	A2/ PU	Port 9 General Purpose I/O Line 6
	IN54	I		IN54 Line of GPTA0
	IN54	I		IN54 Line of GPTA1
	SENT3	I		SENT Digital Input
	OUT54	O1		OUT54 Line of GPTA0
	SENT3	O2		SENT Digital Output
	EN01	O3		MSC0 Device Select Output 1
D20	P9.7	I/O	A2/ PU	Port 9 General Purpose I/O Line 7
	IN55	I		IN55 Line of GPTA0
	IN55	I		IN55 Line of GPTA1
	SENT4	I		SENT Digital Input
	OUT55	O1		OUT55 Line of GPTA0
	SENT4	O2		SENT Digital Output
	SOP0B	O3		MSC0 serial Data Output
C20	P9.8	I/O	A2/ PU	Port 9 General Purpose I/O Line 8
	SENT6	I		SENT Digital Input
	COU62	O1		CCU63
	SENT6	O2		SENT Digital Output
	FCLP0B	O3		MSC0 Clock Output

Pinning TC1793 Pin Configuration

Table 2 Pin Definitions and Functions (cont'd)

Pin	Symbol	Ctrl.	Type	Function
A21	P9.9	I/O	A1/ PU	Port 9 General Purpose I/O Line 9
	SENT0	I		SENT Digital Input
	Reserved	O1		-
	SENT0	O2		SENT Digital Output
	Reserved	O3		-
B21	P9.10	I/O	A1/ PU	Port 9 General Purpose I/O Line 10
	EMGSTOP	I		Emergency Stop
	SENT7	I		SENT Digital Input
	COU63	O1		CCU63
	SENT7	O2		SENT Digital Output
	Reserved	O3		-
C21	P9.11	I/O	A1/ PU	Port 9 General Purpose I/O Line 11
	SENT2	I		SENT Digital Input
	Reserved	O1		-
	SENT2	O2		SENT Digital Output
	Reserved	O3		-
D21	P9.12	I/O	A1/ PU	Port 9 General Purpose I/O Line 12
	SENT5	I		SENT Digital Input
	Reserved	O1		-
	SENT5	O2		SENT Digital Output
	Reserved	O3		-

Pinning TC1793 Pin Configuration

Table 2 Pin Definitions and Functions (cont'd)

Pin	Symbol	Ctrl.	Type	Function
C26	P9.13	I/O	A2/ PU	Port 9 General Purpose I/O Line 13
	$\overline{\text{BRKIN}}$	I		OCDS Break Input
	ECTT1	I		TTCAN Input
	Reserved	O1		-
	Reserved	O2		-
	Reserved	O3		-
	$\overline{\text{BRKOUT}}$	O		OCDS Break Output
D26	P9.14	I/O	A2/ PU	Port 9 General Purpose I/O Line 14
	$\overline{\text{BRKIN}}$	I		OCDS Break Input
	ECTT2	I		TTCAN Input
	REQ15	I		External trigger Input 15
	Reserved	O1		-
	Reserved	O2		-
	Reserved	O3		-
	$\overline{\text{BRKOUT}}$	O		OCDS Break Output
Port 10				
AE15	P10.0	I/O	A2/ PU	Port 10 General Purpose I/O Line 0
	MRST0	I		SSC0 Master Receive Input (Master Mode)
	MRST0	O1		SSC0 Slave Transmit Output (Slave Mode)
	Reserved	O2		-
	Reserved	O3		-

Pinning TC1793 Pin Configuration

Table 2 Pin Definitions and Functions (cont'd)

Pin	Symbol	Ctrl.	Type	Function
AF15	P10.1	I/O	A2/ PU	Port 10 General Purpose I/O Line 1
	MTSR0	I		SSC0 Slave Receive Input (Slave Mode)
	MRSTG0	I		SSC Guardian 0 Master Receive Input (Master Mode)
	MTSR0	O1		SSC0 Master Transmit Output (Master Mode)
	Reserved	O2		-
	Reserved	O3		-
AD15	P10.2	I/O	A1/ PU	Port 10 General Purpose I/O Line 2
	SLSI0	I		SSC0 Slave Select Input
	Reserved	O1		-
	Reserved	O2		-
	Reserved	O3		-
AF14	P10.3	I/O	A2/ PU	Port 10 General Purpose I/O Line 3
	SCLK0	I		SSC0 Clock Input/Output
	SCLK0	O1		SSC0 Clock Input/Output
	Reserved	O2		-
	Reserved	O3		-
AE14	P10.4	I/O	A1+/ PU	Port 10 General Purpose I/O Line 4
	SLSO0	O1		SSC0 Slave Select Output Line 0
	Reserved	O2		-
	Reserved	O3		-
AC15	P10.5	I/O	A1+/ PU	Port 10 General Purpose I/O Line 5
	SLSO1	O1		SSC0 Slave Select Output Line 1
	Reserved	O2		-
	Reserved	O3		-

Pinning TC1793 Pin Configuration

Table 2 Pin Definitions and Functions (cont'd)

Pin	Symbol	Ctrl.	Type	Function
Port 11				
J26	P11.0	I/O	B/ PU	Port 11 General Purpose I/O Line 0
	Reserved	O1		-
	Reserved	O2		-
	Reserved	O3		-
	A0	O		EBU Address Bus Line 0
K25	P11.1	I/O	B/ PU	Port 11 General Purpose I/O Line 1
	Reserved	O1		-
	Reserved	O2		-
	Reserved	O3		-
	A1	O		EBU Address Bus Line 1
K26	P11.2	I/O	B/ PU	Port 11 General Purpose I/O Line 2
	Reserved	O1		-
	Reserved	O2		-
	Reserved	O3		-
	A2	O		EBU Address Bus Line 2
J23	P11.3	I/O	B/ PU	Port 11 General Purpose I/O Line 3
	Reserved	O1		-
	Reserved	O2		-
	Reserved	O3		-
	A3	O		EBU Address Bus Line 3
K24	P11.4	I/O	B/ PU	Port 11 General Purpose I/O Line 4
	Reserved	O1		-
	Reserved	O2		-
	Reserved	O3		-
	A4	O		EBU Address Bus Line 4

Pinning TC1793 Pin Configuration

Table 2 Pin Definitions and Functions (cont'd)

Pin	Symbol	Ctrl.	Type	Function
L25	P11.5	I/O	B/ PU	Port 11 General Purpose I/O Line 5
	Reserved	O1		-
	Reserved	O2		-
	Reserved	O3		-
	A5	O		EBU Address Bus Line 5
L26	P11.6	I/O	B/ PU	Port 11 General Purpose I/O Line 6
	Reserved	O1		-
	Reserved	O2		-
	Reserved	O3		-
	A6	O		EBU Address Bus Line 6
K23	P11.7	I/O	B/ PU	Port 11 General Purpose I/O Line 7
	Reserved	O1		-
	Reserved	O2		-
	Reserved	O3		-
	A7	O		EBU Address Bus Line 7
M26	P11.8	I/O	B/ PU	Port 11 General Purpose I/O Line 8
	Reserved	O1		-
	Reserved	O2		-
	Reserved	O3		-
	A8	O		EBU Address Bus Line 8
M25	P11.9	I/O	B/ PU	Port 11 General Purpose I/O Line 9
	Reserved	O1		-
	Reserved	O2		-
	Reserved	O3		-
	A9	O		EBU Address Bus Line 9

Pinning TC1793 Pin Configuration

Table 2 Pin Definitions and Functions (cont'd)

Pin	Symbol	Ctrl.	Type	Function
M24	P11.10	I/O	B/ PU	Port 11 General Purpose I/O Line 10
	Reserved	O1		-
	Reserved	O2		-
	Reserved	O3		-
	A10	O		EBU Address Bus Line 10
L24	P11.11	I/O	B/ PU	Port 11 General Purpose I/O Line 11
	Reserved	O1		-
	Reserved	O2		-
	Reserved	O3		-
	A11	O		EBU Address Bus Line 11
N26	P11.12	I/O	B/ PU	Port 11 General Purpose I/O Line 12
	Reserved	O1		-
	Reserved	O2		-
	Reserved	O3		-
	A12	O		EBU Address Bus Line 12
N23	P11.13	I/O	B/ PU	Port 11 General Purpose I/O Line 13
	Reserved	O1		-
	Reserved	O2		-
	Reserved	O3		-
	A13	O		EBU Address Bus Line 13
N24	P11.14	I/O	B/ PU	Port 11 General Purpose I/O Line 14
	Reserved	O1		-
	Reserved	O2		-
	Reserved	O3		-
	A14	O		EBU Address Bus Line 14

Pinning TC1793 Pin Configuration

Table 2 Pin Definitions and Functions (cont'd)

Pin	Symbol	Ctrl.	Type	Function
N25	P11.15	I/O	B/ PU	Port 11 General Purpose I/O Line 15
	Reserved	O1		-
	Reserved	O2		-
	Reserved	O3		-
	A15	O		EBU Address Bus Line 15
Port 12				
P26	P12.0	I/O	B/ PU	Port 12 General Purpose I/O Line 0
	Reserved	O1		-
	Reserved	O2		-
	Reserved	O3		-
	A16	O		EBU Address Bus Line 16
P24	P12.1	I/O	B/ PU	Port 12 General Purpose I/O Line 1
	Reserved	O1		-
	Reserved	O2		-
	Reserved	O3		-
	A17	O		EBU Address Bus Line 17
P25	P12.2	I/O	B/ PU	Port 12 General Purpose I/O Line 2
	Reserved	O1		-
	Reserved	O2		-
	Reserved	O3		-
	A18	O		EBU Address Bus Line 18
R24	P12.3	I/O	B/ PU	Port 12 General Purpose I/O Line 3
	Reserved	O1		-
	Reserved	O2		-
	Reserved	O3		-
	A19	O		EBU Address Bus Line 19

Pinning TC1793 Pin Configuration

Table 2 Pin Definitions and Functions (cont'd)

Pin	Symbol	Ctrl.	Type	Function
R26	P12.4	I/O	B/ PU	Port 12 General Purpose I/O Line 4
	Reserved	O1		-
	Reserved	O2		-
	Reserved	O3		-
	A20	O		EBU Address Bus Line 20
R25	P12.5	I/O	B/ PU	Port 12 General Purpose I/O Line 5
	Reserved	O1		-
	Reserved	O2		-
	Reserved	O3		-
	A21	O		EBU Address Bus Line 21
J24	P12.6	I/O	B/ PU	Port 12 General Purpose I/O Line 6
	Reserved	O1		-
	Reserved	O2		-
	Reserved	O3		-
	A22	O		EBU Address Bus Line 22
J25	P12.7	I/O	B/ PU	Port 12 General Purpose I/O Line 7
	Reserved	O1		-
	Reserved	O2		-
	Reserved	O3		-
	A23	O		EBU Address Bus Line 23
Port 13				

Pinning TC1793 Pin Configuration

Table 2 Pin Definitions and Functions (cont'd)

Pin	Symbol	Ctrl.	Type	Function
T26	P13.0	I/O	B/ PU	Port 13 General Purpose I/O Line 0
	AD0	I		EBU Address/Data Bus Line 0
	OUT88	O1		OUT88 Line of GPTA0
	OUT88	O2		OUT88 Line of GPTA1
	OUT80	O3		OUT80 Line of LTCA2
	AD0	O		EBU Address/Data Bus Line 0
T24	P13.1	I/O	B/ PU	Port 13 General Purpose I/O Line 1
	AD1	I		EBU Address/Data Bus Line 1
	OUT89	O1		OUT89 Line of GPTA0
	OUT89	O2		OUT89 Line of GPTA1
	OUT81	O3		OUT81 Line of LTCA2
	AD1	O		EBU Address/Data Bus Line 1
U26	P13.2	I/O	B/ PU	Port 13 General Purpose I/O Line 2
	AD2	I		EBU Address/Data Bus Line 2
	OUT90	O1		OUT90 Line of GPTA0
	OUT90	O2		OUT90 Line of GPTA1
	OUT82	O3		OUT82 Line of LTCA2
	AD2	O		EBU Address/Data Bus Line 2
T25	P13.3	I/O	B/ PU	Port 13 General Purpose I/O Line 3
	AD3	I		EBU Address/Data Bus Line 3
	OUT91	O1		OUT91 Line of GPTA0
	OUT91	O2		OUT91 Line of GPTA1
	OUT83	O3		OUT83 Line of LTCA2
	AD3	O		EBU Address/Data Bus Line 3

Pinning TC1793 Pin Configuration

Table 2 Pin Definitions and Functions (cont'd)

Pin	Symbol	Ctrl.	Type	Function
V26	P13.4	I/O	B/ PU	Port 13 General Purpose I/O Line 4
	AD4	I		EBU Address/Data Bus Line 4
	OUT92	O1		OUT92 Line of GPTA0
	OUT92	O2		OUT92 Line of GPTA1
	OUT84	O3		OUT84 Line of LTCA2
	AD4	O		EBU Address/Data Bus Line 4
U25	P13.5	I/O	B/ PU	Port 13 General Purpose I/O Line 5
	AD5	I		EBU Address/Data Bus Line 5
	OUT93	O1		OUT93 Line of GPTA0
	OUT93	O2		OUT93 Line of GPTA1
	OUT85	O3		OUT85 Line of LTCA2
	AD5	O		EBU Address/Data Bus Line 5
U23	P13.6	I/O	B/ PU	Port 13 General Purpose I/O Line 6
	AD6	I		EBU Address/Data Bus Line 6
	OUT94	O1		OUT94 Line of GPTA0
	OUT94	O2		OUT94 Line of GPTA1
	OUT86	O3		OUT86 Line of LTCA2
	AD6	O		EBU Address/Data Bus Line 6
W26	P13.7	I/O	B/ PU	Port 13 General Purpose I/O Line 7
	AD7	I		EBU Address/Data Bus Line 7
	OUT95	O1		OUT95 Line of GPTA0
	OUT95	O2		OUT95 Line of GPTA1
	OUT87	O3		OUT87 Line of LTCA2
	AD7	O		EBU Address/Data Bus Line 7

Pinning TC1793 Pin Configuration

Table 2 Pin Definitions and Functions (cont'd)

Pin	Symbol	Ctrl.	Type	Function
V25	P13.8	I/O	B/ PU	Port 13 General Purpose I/O Line 8
	AD8	I		EBU Address/Data Bus Line 8
	OUT96	O1		OUT96 Line of GPTA0
	OUT96	O2		OUT96 Line of GPTA1
	OUT88	O3		OUT88 Line of LTCA2
	AD8	O		EBU Address/Data Bus Line 8
U24	P13.9	I/O	B/ PU	Port 13 General Purpose I/O Line 9
	AD9	I		EBU Address/Data Bus Line 9
	OUT97	O1		OUT97 Line of GPTA0
	OUT97	O2		OUT97 Line of GPTA1
	OUT89	O3		OUT89 Line of LTCA2
	AD9	O		EBU Address/Data Bus Line 9
Y26	P13.10	I/O	B/ PU	Port 13 General Purpose I/O Line 10
	AD10	I		EBU Address/Data Bus Line 10
	OUT98	O1		OUT98 Line of GPTA0
	OUT98	O2		OUT98 Line of GPTA1
	OUT90	O3		OUT90 Line of LTCA2
	AD10	O		EBU Address/Data Bus Line 10
AA26	P13.11	I/O	B/ PU	Port 13 General Purpose I/O Line 11
	AD11	I		EBU Address/Data Bus Line 11
	OUT99	O1		OUT99 Line of GPTA0
	OUT99	O2		OUT99 Line of GPTA1
	OUT91	O3		OUT91 Line of LTCA2
	AD11	O		EBU Address/Data Bus Line 11

Pinning TC1793 Pin Configuration

Table 2 Pin Definitions and Functions (cont'd)

Pin	Symbol	Ctrl.	Type	Function
W25	P13.12	I/O	B/ PU	Port 13 General Purpose I/O Line 12
	AD12	I		EBU Address/Data Bus Line 12
	OUT100	O1		OUT100 Line of GPTA0
	OUT100	O2		OUT100 Line of GPTA1
	OUT92	O3		OUT92 Line of LTCA2
	AD12	O		EBU Address/Data Bus Line 12
V24	P13.13	I/O	B/ PU	Port 13 General Purpose I/O Line 13
	AD13	I		EBU Address/Data Bus Line 13
	OUT101	O1		OUT101 Line of GPTA0
	OUT101	O2		OUT101 Line of GPTA1
	OUT93	O3		OUT93 Line of LTCA2
	AD13	O		EBU Address/Data Bus Line 13
Y25	P13.14	I/O	B/ PU	Port 13 General Purpose I/O Line 14
	AD14	I		EBU Address/Data Bus Line 14
	OUT102	O1		OUT102 Line of GPTA0
	OUT102	O2		OUT102 Line of GPTA1
	OUT94	O3		OUT94 Line of LTCA2
	AD14	O		EBU Address/Data Bus Line 14
AB26	P13.15	I/O	B/ PU	Port 13 General Purpose I/O Line 15
	AD15	I		EBU Address/Data Bus Line 15
	OUT103	O1		OUT103 Line of GPTA0
	OUT103	O2		OUT103 Line of GPTA1
	OUT95	O3		OUT95 Line of LTCA2
	AD15	O		EBU Address/Data Bus Line 15
Port 14				

Table 2 Pin Definitions and Functions (cont'd)

Pin	Symbol	Ctrl.	Type	Function
W24	P14.0	I/O	B/ PU	Port 14 General Purpose I/O Line 0
	AD16	I		EBU Address/Data Bus Line 16
	CC60	O1		CCU60
	OUT96	O2		OUT96 Line of GPTA1
	OUT96	O3		OUT96 Line of LTCA2
	AD16	O		EBU Address/Data Bus Line 16
AA25	P14.1	I/O	B/ PU	Port 14 General Purpose I/O Line 1
	AD17	I		EBU Address/Data Bus Line 17
	CC61	O1		CCU60
	OUT97	O2		OUT97 Line of GPTA1
	OUT97	O3		OUT97 Line of LTCA2
	AD17	O		EBU Address/Data Bus Line 17
Y24	P14.2	I/O	B/ PU	Port 14 General Purpose I/O Line 2
	AD18	I		EBU Address/Data Bus Line 18
	CC62	O1		CCU60
	OUT98	O2		OUT98 Line of GPTA1
	OUT98	O3		OUT98 Line of LTCA2
	AD18	O		EBU Address/Data Bus Line 18
AA23	P14.3	I/O	B/ PU	Port 14 General Purpose I/O Line 3
	AD19	I		EBU Address/Data Bus Line 19
	COU60	O1		CCU60
	OUT99	O2		OUT99 Line of GPTA1
	OUT99	O3		OUT99 Line of LTCA2
	AD19	O		EBU Address/Data Bus Line 19

Pinning TC1793 Pin Configuration

Table 2 Pin Definitions and Functions (cont'd)

Pin	Symbol	Ctrl.	Type	Function
AB25	P14.4	I/O	B/ PU	Port 14 General Purpose I/O Line 4
	AD20	I		EBU Address/Data Bus Line 20
	COU61	O1		CCU60
	OUT100	O2		OUT100 Line of GPTA1
	OUT100	O3		OUT100 Line of LTCA2
	AD20	O		EBU Address/Data Bus Line 20
AB24	P14.5	I/O	B/ PU	Port 14 General Purpose I/O Line 5
	AD21	I		EBU Address/Data Bus Line 21
	COU62	O1		CCU60
	OUT101	O2		OUT101 Line of GPTA1
	OUT101	O3		OUT101 Line of LTCA2
	AD21	O		EBU Address/Data Bus Line 21
AA24	P14.6	I/O	B/ PU	Port 14 General Purpose I/O Line 6
	AD22	I		EBU Address/Data Bus Line 22
	COU63	O1		CCU60
	OUT102	O2		OUT102 Line of GPTA1
	OUT102	O3		OUT102 Line of LTCA2
	AD22	O		EBU Address/Data Bus Line 22
AC26	P14.7	I/O	B/ PU	Port 14 General Purpose I/O Line 7
	AD23	I		EBU Address/Data Bus Line 23
	CC60	O1		CCU61
	OUT103	O2		OUT103 Line of GPTA1
	OUT103	O3		OUT103 Line of LTCA2
	AD23	O		EBU Address/Data Bus Line 23

Pinning TC1793 Pin Configuration

Table 2 Pin Definitions and Functions (cont'd)

Pin	Symbol	Ctrl.	Type	Function
AD26	P14.8	I/O	B/ PU	Port 14 General Purpose I/O Line 8
	AD24	I		EBU Address/Data Bus Line 24
	CC61	O1		CCU61
	T3OUT	O2		GPT120
	OUT104	O3		OUT104 Line of LTCA2
	AD24	O		EBU Address/Data Bus Line 24
AC25	P14.9	I/O	B/ PU	Port 14 General Purpose I/O Line 9
	AD25	I		EBU Address/Data Bus Line 25
	CC62	O1		CCU61
	T3OUT	O2		GPT121
	OUT105	O3		OUT105 Line of LTCA2
	AD25	O		EBU Address/Data Bus Line 25
AE26	P14.10	I/O	B/ PU	Port 14 General Purpose I/O Line 10
	AD26	I		EBU Address/Data Bus Line 26
	COOUT60	O1		CCU61
	T6OUT	O1		GPT120
	OUT106	O3		OUT106 Line of LTCA2
	AD26	O		EBU Address/Data Bus Line 26
AD25	P14.11	I/O	B/ PU	Port 14 General Purpose I/O Line 11
	AD27	I		EBU Address/Data Bus Line 27
	COOUT61	O1		CCU61
	T6OUT	O1		GPT121
	OUT107	O3		OUT107 Line of LTCA2
	AD27	O		EBU Address/Data Bus Line 27

Pinning TC1793 Pin Configuration

Table 2 Pin Definitions and Functions (cont'd)

Pin	Symbol	Ctrl.	Type	Function
AC24	P14.12	I/O	B/ PU	Port 14 General Purpose I/O Line 12
	AD28	I		EBU Address/Data Bus Line 28
	COU62	O1		CCU61
	OUT108	O2		OUT108 Line of GPTA1
	OUT108	O3		OUT108 Line of LTCA2
	AD28	O		EBU Address/Data Bus Line 28
AE25	P14.13	I/O	B/ PU	Port 14 General Purpose I/O Line 13
	AD29	I		EBU Address/Data Bus Line 29
	COU63	O1		CCU61
	OUT109	O2		OUT109 Line of GPTA1
	OUT109	O3		OUT109 Line of LTCA2
	AD29	O		EBU Address/Data Bus Line 29
AE24	P14.14	I/O	B/ PU	Port 14 General Purpose I/O Line 14
	AD30	I		EBU Address/Data Bus Line 30
	T3INC	I		GPT120
	T3IND	I		GPT121
	OUT110	O1		OUT110 Line of GPTA0
	OUT110	O2		OUT110 Line of GPTA1
	OUT110	O3		OUT110 Line of LTCA2
	AD30	O		EBU Address/Data Bus Line 30

Pinning TC1793 Pin Configuration

Table 2 Pin Definitions and Functions (cont'd)

Pin	Symbol	Ctrl.	Type	Function
AD24	P14.15	I/O	B/ PU	Port 14 General Purpose I/O Line 15
	AD31	I		EBU Address/Data Bus Line 31
	T3EUDC	I		GPT120
	T3EUDD	I		GPT121
	OUT111	O1		OUT111 Line of GPTA0
	OUT111	O2		OUT111 Line of GPTA1
	OUT111	O3		OUT111 Line of LTCA2
	AD31	O		EBU Address/Data Bus Line 31
Port 15				
AE21	P15.0	I/O	B/ PU	Port 15 General Purpose I/O Line 0
	T4INC	I		GPT120
	T4IND	I		GPT121
	CCPOS2B	I		CCU60
	Reserved	O1		-
	Reserved	O2		-
	Reserved	O3		-
	CS0	O		Chip Select Output Line 0
AD21	P15.1	I/O	B/ PU	Port 15 General Purpose I/O Line 1
	T4EUDC	I		GPT120
	T4EUDD	I		GPT121
	CCPOS2B	I		CCU61
	Reserved	O1		-
	Reserved	O2		-
	Reserved	O3		-
	CS1	O		Chip Select Output Line 1

Pinning TC1793 Pin Configuration

Table 2 Pin Definitions and Functions (cont'd)

Pin	Symbol	Ctrl.	Type	Function
AD20	P15.2	I/O	B/ PU	Port 15 General Purpose I/O Line 2
	Reserved	O1		-
	Reserved	O2		-
	Reserved	O3		-
	CS2	O		Chip Select Output Line 2
AD19	P15.3	I/O	B/ PU	Port 15 General Purpose I/O Line 3
	Reserved	O1		-
	Reserved	O2		-
	Reserved	O3		-
	CS3	O		Chip Select Output Line 3
AE17	P15.4	I/O	B/ PU	Port 15 General Purpose I/O Line 4
	Reserved	O1		-
	Reserved	O2		-
	Reserved	O3		-
	BC0	O		Byte Control Line 0
AD17	P15.5	I/O	B/ PU	Port 15 General Purpose I/O Line 5
	Reserved	O1		-
	Reserved	O2		-
	Reserved	O3		-
	BC1	O		Byte Control Line 1
AF18	P15.6	I/O	B/ PU	Port 15 General Purpose I/O Line 6
	Reserved	O1		-
	Reserved	O2		-
	Reserved	O3		-
	BC2	O		Byte Control Line 2

Pinning TC1793 Pin Configuration

Table 2 Pin Definitions and Functions (cont'd)

Pin	Symbol	Ctrl.	Type	Function
AE18	P15.7	I/O	B/ PU	Port 15 General Purpose I/O Line 7
	Reserved	O1		-
	Reserved	O2		-
	Reserved	O3		-
	BC3	O		Byte Control Line 3
AF20	P15.8	I/O	B/ PU	Port 15 General Purpose I/O Line 8
	Reserved	O1		-
	Reserved	O2		-
	Reserved	O3		-
	RD	O		Read Control Line
AF21	P15.9	I/O	B/ PU	Port 15 General Purpose I/O Line 9
	Reserved	O1		-
	Reserved	O2		-
	Reserved	O3		-
	RD/WR	O		Write Control Line
AF22	P15.10	I/O	B/ PU	Port 15 General Purpose I/O Line 10
	Reserved	O1		-
	Reserved	O2		-
	Reserved	O3		-
	ADV	O		Address Valid Output
AE20	P15.11	I/O	B/ PU	Port 15 General Purpose I/O Line 11
	WAIT	I		Wait Input for inserting Wait-States
	Reserved	O1		-
	Reserved	O2		-
	Reserved	O3		-

Pinning TC1793 Pin Configuration

Table 2 Pin Definitions and Functions (cont'd)

Pin	Symbol	Ctrl.	Type	Function
AF19	P15.12	I/O	B/ PU	Port 15 General Purpose I/O Line 12
	Reserved	O1		-
	Reserved	O2		-
	Reserved	O3		-
	MR/W	O		Motorola-style Read/Write Control Signal
AF23	P15.13	I/O	B/ PU	Port 15 General Purpose I/O Line 13
	Reserved	O1		-
	Reserved	O2		-
	Reserved	O3		-
	BAA	O		Burst Address Advance Output
AF24	P15.14	I/O	B/ PU	Port 15 General Purpose I/O Line 14
	BFCLKI	I		Burst FLASH Clock Input (Clock Feedback).
	Reserved	O1		-
	Reserved	O2		-
	Reserved	O3		-
AF25	P15.15	I/O	B/ PU	Port 15 General Purpose I/O Line 15
	Reserved	O1		-
	Reserved	O2		-
	Reserved	O3		-
	BFCLKO	O		Burst Mode Flash Clock Output (Non-Differential)
Port 16				

Pinning TC1793 Pin Configuration

Table 2 Pin Definitions and Functions (cont'd)

Pin	Symbol	Ctrl.	Type	Function
AF17	P16.0	I/O	B/ PU	Port 16 General Purpose I/O Line 0
	HOLD	I		Hold Request Input
	Reserved	O1		-
	Reserved	O2		-
	Reserved	O3		-
AD18	P16.1	I/O	B/ PU	Port 16 General Purpose I/O Line 1
	HLDA	I		Hold Acknowledge Output
	Reserved	O1		-
	Reserved	O2		-
	Reserved	O3		-
	HLDA	O		Hold Acknowledge Output
AD22	P16.2	I/O	B/ PU	Port 16 General Purpose I/O Line 2
	Reserved	O1		-
	Reserved	O2		-
	Reserved	O3		-
	BREQ	O		Bus Request Output
AE19	P16.3	I/O	B/ PU	Port 16 General Purpose I/O Line 3
	Reserved	O1		-
	Reserved	O2		-
	Reserved	O3		-
	CSCOMB	O		Combined Chip Select Output
Port 17				
AC1	P17.0	I	D / S	Port 17 General Purpose I Line 0⁴⁾
	SENT0	I		SENT Digital Input 0
	AN8	I		Analog Input : ADC0.CH8⁵⁾

Pinning TC1793 Pin Configuration
Table 2 Pin Definitions and Functions (cont'd)

Pin	Symbol	Ctrl.	Type	Function
AB2	P17.1	I	D / S	Port 17 General Purpose I Line 1⁴⁾
	SENT1	I		SENT Digital Input 1
	AN9	I		Analog Input : ADC0.CH9⁵⁾
Y3	P17.2	I	D / S	Port 17 General Purpose I Line 2⁴⁾
	SENT2	I		SENT Digital Input 2
	AN10	I		Analog Input : ADC0.CH10⁵⁾
AA2	P17.3	I	D / S	Port 17 General Purpose I Line 3⁴⁾
	SENT3	I		SENT Digital Input 3
	AN11	I		Analog Input : ADC0.CH11⁵⁾
AB1	P17.4	I	D / S	Port 17 General Purpose I Line 4⁴⁾
	SENT4	I		SENT Digital Input 4
	AN12	I		Analog Input : ADC0.CH12⁵⁾
W3	P17.5	I	D / S	Port 17 General Purpose I Line 5⁴⁾
	SENT5	I		SENT Digital Input 5
	AN13	I		Analog Input : ADC0.CH13⁵⁾
Y2	P17.6	I	D / S	Port 17 General Purpose I Line 6⁴⁾
	SENT6	I		SENT Digital Input 6
	AN14	I		Analog Input : ADC0.CH14⁵⁾
AA1	P17.7	I	D / S	Port 17 General Purpose I Line 7⁴⁾
	SENT7	I		SENT Digital Input 7
	AN15	I		Analog Input : ADC0.CH15⁵⁾
AE3	P17.8	I	D / S	Port 17 General Purpose I Line 8⁴⁾
	SENT0	I		SENT Digital Input 0
	AN36	I		Analog Input : ADC2.CH4⁵⁾

Pinning TC1793 Pin Configuration

Table 2 Pin Definitions and Functions (cont'd)

Pin	Symbol	Ctrl.	Type	Function
AF2	P17.9	I	D / S	Port 17 General Purpose I Line 9 ⁴⁾
	SENT1	I		SENT Digital Input 1
	AN37	I		Analog Input : ADC2.CH5 ⁵⁾
AC4	P17.10	I	D / S	Port 17 General Purpose I Line 10 ⁴⁾
	SENT2	I		SENT Digital Input 2
	AN38	I		Analog Input : ADC2.CH6 ⁵⁾
AF3	P17.11	I	D / S	Port 17 General Purpose I Line 11 ⁴⁾
	SENT3	I		SENT Digital Input 3
	AN39	I		Analog Input : ADC2.CH7 ⁵⁾
AD4	P17.12	I	D / S	Port 17 General Purpose I Line 12 ⁴⁾
	SENT4	I		SENT Digital Input 4
	AN40	I		Analog Input : ADC2.CH8 ⁵⁾
AE4	P17.13	I	D / S	Port 17 General Purpose I Line 13 ⁴⁾
	SENT5	I		SENT Digital Input 5
	AN41	I		Analog Input : ADC2.CH9 ⁵⁾
AC5	P17.14	I	D / S	Port 17 General Purpose I Line 14 ⁴⁾
	SENT6	I		SENT Digital Input 6
	AN42	I		Analog Input : ADC2.CH10 ⁵⁾
AF4	P17.15	I	D / S	Port 17 General Purpose I Line 15 ⁴⁾
	SENT7	I		SENT Digital Input 7
	AN43	I		Analog Input : ADC2.CH11 ⁵⁾
Analog Input Port				
AE1	AN0	I	D	Analog Input 0: ADC0.CH0 ⁵⁾
AD2	AN1	I	D	Analog Input 1: ADC0.CH1 ⁵⁾
AA4	AN2	I	D	Analog Input 2: ADC0.CH2 ⁵⁾
AB3	AN3	I	D	Analog Input 3: ADC0.CH3 ⁵⁾

Pinning TC1793 Pin Configuration
Table 2 Pin Definitions and Functions (cont'd)

Pin	Symbol	Ctrl.	Type	Function
AC2	AN4	I	D	Analog Input 4: ADC0.CH4, ADC2.CH12 ⁵⁾
AA3	AN5	I	D	Analog Input 5: ADC0.CH5, ADC2.CH13 ⁵⁾
AD1	AN6	I	D	Analog Input 6: ADC0.CH6, ADC2.CH14 ⁵⁾
AB4	AN7	I	D	Analog Input 7: ADC0.CH7, ADC2.CH15 ⁵⁾
AC1	AN8	I	D / S	Analog Input 8: ADC0.CH8, SENT0 ⁵⁾
AB2	AN9	I	D / S	Analog Input 9: ADC0.CH9, SENT1 ⁵⁾
Y3	AN10	I	D / S	Analog Input 10: ADC0.CH10, SENT2 ⁵⁾
AA2	AN11	I	D / S	Analog Input 11: ADC0.CH11, SENT3 ⁵⁾
AB1	AN12	I	D / S	Analog Input 12: ADC0.CH12, SENT4 ⁵⁾
W3	AN13	I	D / S	Analog Input 13: ADC0.CH13, SENT5 ⁵⁾
Y2	AN14	I	D / S	Analog Input 14: ADC0.CH14, SENT6 ⁵⁾
AA1	AN15	I	D / S	Analog Input 15: ADC0.CH15, SENT7 ⁵⁾
V4	AN16	I	D	Analog Input 16: ADC1.CH0 ⁵⁾
W2	AN17	I	D	Analog Input 17: ADC1.CH1 ⁵⁾
Y1	AN18	I	D	Analog Input 18: ADC1.CH2 ⁵⁾
V3	AN19	I	D	Analog Input 19: ADC1.CH3 ⁵⁾
W1	AN20	I	D	Analog Input 20: ADC1.CH4 ⁵⁾
V2	AN21	I	D	Analog Input 21: ADC1.CH5 ⁵⁾
V1	AN22	I	D	Analog Input 22: ADC1.CH6 ⁵⁾
U1	AN23	I	D	Analog Input 23: ADC1.CH7 ⁵⁾
AC8	AN24	I	D	Analog Input 24: ADC1.CH8, FADC_FADIN0P ⁶⁾
AD8	AN25	I	D	Analog Input 25: ADC1.CH9, FADC_FADIN0N ⁶⁾
AC7	AN26	I	D	Analog Input 26: ADC1.CH10, FADC_FADIN1P ⁶⁾

Pinning TC1793 Pin Configuration

Table 2 Pin Definitions and Functions (cont'd)

Pin	Symbol	Ctrl.	Type	Function
AD7	AN27	I	D	Analog Input 27: ADC1.CH11, FADC_FADIN1N ⁶⁾
AE6	AN28	I	D	Analog Input 28: ADC1.CH12, FADC_FADIN2P ⁶⁾
AF6	AN29	I	D	Analog Input 29: ADC1.CH13, FADC_FADIN2N ⁶⁾
AE7	AN30	I	D	Analog Input 30: ADC1.CH14, FADC_FADIN3P ⁶⁾
AF7	AN31	I	D	Analog Input 31: ADC1.CH15, FADC_FADIN3N ⁶⁾
AC3	AN32	I	D	Analog Input 32: ADC2.CH0 ⁵⁾
AE2	AN33	I	D	Analog Input 33: ADC2.CH1 ⁵⁾
AD3	AN34	I	D	Analog Input 34: ADC2.CH2 ⁵⁾
AD5	AN35	I	D	Analog Input 35: ADC2.CH3 ⁵⁾
AE3	AN36	I	D / S	Analog Input 36: ADC2.CH4, SENT0 ⁵⁾
AF2	AN37	I	D / S	Analog Input 37: ADC2.CH5, SENT1 ⁵⁾
AC4	AN38	I	D / S	Analog Input 38: ADC2.CH6, SENT2 ⁵⁾
AF3	AN39	I	D / S	Analog Input 39: ADC2.CH7, SENT3 ⁵⁾
AD4	AN40	I	D / S	Analog Input 40: ADC2.CH8, SENT4 ⁵⁾
AE4	AN41	I	D / S	Analog Input 41: ADC2.CH9, SENT5 ⁵⁾
AC5	AN42	I	D / S	Analog Input 42: ADC2.CH10, SENT6 ⁵⁾
AF4	AN43	I	D / S	Analog Input 43: ADC2.CH11, SENT7 ⁵⁾
System I/O				
B22	$\overline{\text{PORST}}$	I	PD	Power-on Reset Input
A23	$\overline{\text{ESR0}}$	I/O	A2	External System Request Reset Input 0 Default configuration during and after reset is open-drain driver. The driver drives low during power-on reset.

Pinning TC1793 Pin Configuration

Table 2 Pin Definitions and Functions (cont'd)

Pin	Symbol	Ctrl.	Type	Function
A22	$\overline{\text{ESR1}}$	I/O	A2/ PD	External System Request Reset Input 1
E24	TCK	I	PD	JTAG Module Clock Input
	DAP0	I		Device Access Port Line 0
E25	TDI	I	A2/ PU	JTAG Module Serial Data Input
	$\overline{\text{BRKIN}}$	I		OCDS Break Input (Alternate Output)
	$\overline{\text{BRKOUT}}$	O		OCDS Break Output (Alternate Input)
B23	$\overline{\text{TESTMODE}}$	I	PU	Test Mode Select Input
F24	TMS	I	A2/ PD	JTAG Module State Machine Control Input
	DAP1	I/O		Device Access Port Line 1
F23	$\overline{\text{TRST}}$	I	PD	JTAG Module Reset/Enable Input
G26	XTAL1	I		Main Oscillator/PLL/Clock Generator Input
G25	XTAL2	O		Main Oscillator/PLL/Clock Generator Output
D25	TDO	O	A2/ PU	JTAG Module Serial Data Output
	$\overline{\text{BRKIN}}$	I		OCDS Break Input (Alternate Input)
	$\overline{\text{BRKOUT}}$	O		OCDS Break Output (Alternate Output)
	DAP2	O		Device Access Port Line 2
Power Supply				
W4	V_{DDM}	-	-	ADC Analog Part Power Supply (3.3V - 5V)
Y4	V_{SSM}	-	-	ADC Analog Part Ground
AE5	V_{AREF0}	-	-	ADC0 Reference Voltage
AF5	V_{AGND0}	-	-	ADC0 Reference Ground
	V_{AGND2}	-	-	ADC2 Reference Ground
AD6	V_{AREF1}	-	-	ADC1 Reference Voltage
AC6	V_{AGND1}	-	-	ADC1 Reference Ground
AD9	V_{AREF2}	-	-	ADC2 Reference Voltage

Pinning TC1793 Pin Configuration

Table 2 Pin Definitions and Functions (cont'd)

Pin	Symbol	Ctrl.	Type	Function
AF8	V_{FAREF}	-	-	FADC Reference Voltage
AE8	V_{FAGND}	-	-	FADC Reference Ground
AE9	V_{DDMF}	-	-	FADC Analog Part Power Supply (3.3V)
AC9	V_{DDAF}	-	-	FADC Analog Part Logic Power Supply (1.3V)
AF9	V_{SSMF}	-	-	FADC Analog Part Ground
	V_{SSAF}	-	-	FADC Analog Part Logic Ground
A18, B18, H3	V_{DDFL3}	-	-	Flash Power Supply (3.3V)
F25	V_{SSOSC}	-	-	Main Oscillator Ground
	V_{SS}	-	-	Digital Ground
F26	V_{DDOSC}	-	-	Main Oscillator Power Supply (1.3V)
E26	V_{DDOSC3}	-	-	Main Oscillator Power Supply (3.3V)
G23	V_{DDPF}	-	-	E-Ray PLL Power Supply (1.3V)
G24	V_{DDPF3}	-	-	E-Ray PLL Power Supply (3.3V)
AC11, AC20, AB23, V23, P23, E23, D24, C25, B26, D16, D9, H4, R4	V_{DD}	-	-	Digital Core Power Supply (1.3V)

Pinning TC1793 Pin Configuration

Table 2 Pin Definitions and Functions (cont'd)

Pin	Symbol	Ctrl.	Type	Function
AC16, AD16, AE16, AF16, D22, C23, B24, A25, D14, D7, K4	V_{DDP}	-	-	Port Power Supply (3.3V)
H23, H24, H25, H26, M23, T23, Y23, AC18, AC22	V_{DDEBU}	-	-	EBU Port Power Supply (1.8V - 2.5V - 3.3V)
R1	V_{DDSB}	-	-	Emulation Stand-by SRAM Power Supply (1.3V) (Emulation device only) <i>Note: This pin is N.C. in a productive device.</i>
AC10, AC17, AC19, AC23, W23, R23, L23, D23, C24, B25, A26, D15, D8, J4, T4	V_{SS}	-	-	Digital Ground (outer balls)

Pinning TC1793 Pin Configuration

Table 2 Pin Definitions and Functions (cont'd)

Pin	Symbol	Ctrl.	Type	Function
K10, K11, K12, K13, K14, K15, K16, K17	V_{SS}	-	-	Digital Ground (center balls)
L10, L11, L12, L13, L14, L15, L16, L17	V_{SS}	-	-	Digital Ground (center balls cont'd)
M10, M11, M12, M13, M14, M15, M16, M17	V_{SS}	-	-	Digital Ground (center balls cont'd)
N10, N11, N12, N13, N14, N15, N16, N17	V_{SS}	-	-	Digital Ground (center balls cont'd)

Pinning TC1793 Pin Configuration

Table 2 Pin Definitions and Functions (cont'd)

Pin	Symbol	Ctrl.	Type	Function
P10, P11, P12, P13, P14, P15, P16, P17	V_{SS}	-	-	Digital Ground (center balls cont'd)
R10, R11, R12, R13, R14, R15, R16, R17	V_{SS}	-	-	Digital Ground (center balls cont'd)
T10, T11, T12, T13, T14, T15, T16, T17	V_{SS}	-	-	Digital Ground (center balls cont'd)
U10, U11, U12, U13, U14, U15, U16, U17	V_{SS}	-	-	Digital Ground (center balls cont'd)

Pinning TC1793 Pin Configuration

Table 2 Pin Definitions and Functions (cont'd)

Pin	Symbol	Ctrl.	Type	Function
A1, AF1, AF26, A24, C22, AC21, AD23, AE22, AE23	N.C.	-	-	Not connected. These pins are reserved for future extension and shall not be connected externally.

- 1) Only applicable in TC1793ED. Reserved in TC1793PD.
- 2) Only available for SAK-TC1793F-512F270EF, SAK-TC1793F-512F270EB, SAK-TC1793F-512F200EF, and SAK-TC1793F-512F200EB.
- 3) The MTSR output of SSCx is overlaid with the MRSTG input of the related SSCGx
- 4) Analog Input overlaid with a SENT Digital Input. The related port logic is used configure the input as either analog input (default after reset) or digital input. The related port logic supports only the port input features as the connected pads are input pads only.
- 5) IOZ1 valid for this pin is the parameter with overlaid = No in the ADC parameter table.
- 6) IOZ1 valid for this pin is the parameter with overlaid = Yes in the ADC parameter table.

Legend for Table 2

Column "Ctrl.":

 I = Input (for GPIO port lines with IOCR bit field selection PCx = 0XXX_B)

O = Output

 O0 = Output with IOCR bit field selection PCx = 1X00_B

 O1 = Output with IOCR bit field selection PCx = 1X01_B (ALT1)

 O2 = Output with IOCR bit field selection PCx = 1X10_B (ALT2)

O3 = Output with IOCR bit field selection PCx = 1X11 (ALT3)

Column "Type":

A1 = Pad class A1 (LVTTTL)

A1+ = Pad class A1+ (LVTTTL)

A2 = Pad class A2 (LVTTTL)

B = Pad class B (LVTTTL)

F = Pad class F (LVDS/CMOS)

D = Pad class D (ADC)

S = Pad class S (SENT)

 PU = with pull-up device connected during reset ($\overline{\text{PORST}} = 0$)

 PD = with pull-down device connected during reset ($\overline{\text{PORST}} = 0$)

 TR = tri-state during reset ($\overline{\text{PORST}} = 0$)

4 Identification Registers

The Identification Registers uniquely identify the whole device.

Table 3 SAK-TC1793F-512F270EF Identification Registers

Short Name	Value	Address	Stepping
CBS_JDPID	0000 6350 _H	F000 0408 _H	AB
CBS_JTAGID	1018 E083 _H	F000 0464 _H	AB
SCU_CHIPID	8700 9702 _H	F000 0640 _H	AB
SCU_MANID	0000 1820 _H	F000 0644 _H	AB
SCU_RTID	0000 0000 _H	F000 0648 _H	AB

Table 4 SAK-TC1793F-512F270EB Identification Registers

Short Name	Value	Address	Stepping
CBS_JDPID	0000 6350 _H	F000 0408 _H	AB
CBS_JTAGID	1018 E083 _H	F000 0464 _H	AB
SCU_CHIPID	0700 9702 _H	F000 0640 _H	AB
SCU_MANID	0000 1820 _H	F000 0644 _H	AB
SCU_RTID	0000 0000 _H	F000 0648 _H	AB

Table 5 SAK-TC1793F-512F200EF Identification Registers

Short Name	Value	Address	Stepping
CBS_JDPID	0000 6350 _H	F000 0408 _H	AB
CBS_JTAGID	1018 E083 _H	F000 0464 _H	AB
SCU_CHIPID	9700 9702 _H	F000 0640 _H	AB
SCU_MANID	0000 1820 _H	F000 0644 _H	AB
SCU_RTID	0000 0000 _H	F000 0648 _H	AB

Table 6 SAK-TC1793F-512F200EB Identification Registers

Short Name	Value	Address	Stepping
CBS_JDPID	0000 6350 _H	F000 0408 _H	AB
CBS_JTAGID	1018 E083 _H	F000 0464 _H	AB
SCU_CHIPID	1700 9702 _H	F000 0640 _H	AB

Identification Registers

Table 6 SAK-TC1793F-512F200EB Identification Registers (cont'd)

Short Name	Value	Address	Stepping
SCU_MANID	0000 1820 _H	F000 0644 _H	AB
SCU_RTID	0000 0000 _H	F000 0648 _H	AB

Table 7 SAK-TC1793N-512F270EF Identification Registers

Short Name	Value	Address	Stepping
CBS_JDPID	0000 6350 _H	F000 0408 _H	AB
CBS_JTAGID	1018 E083 _H	F000 0464 _H	AB
SCU_CHIPID	8700 B102 _H	F000 0640 _H	AB
SCU_MANID	0000 1820 _H	F000 0644 _H	AB
SCU_RTID	0000 0000 _H	F000 0648 _H	AB

Table 8 SAK-TC1793S-512F270EF Identification Registers

Short Name	Value	Address	Stepping
CBS_JDPID	0000 6350 _H	F000 0408 _H	AB
CBS_JTAGID	1018 E083 _H	F000 0464 _H	AB
SCU_CHIPID	8700 AB02 _H	F000 0640 _H	AB
SCU_MANID	0000 1820 _H	F000 0644 _H	AB
SCU_RTID	0000 0000 _H	F000 0648 _H	AB

5 Electrical Parameters

This specification provides all electrical parameters of the TC1793.

5.1 General Parameters

5.1.1 Parameter Interpretation

The parameters listed in this section partly represent the characteristics of the TC1793 and partly its requirements on the system. To aid interpreting the parameters easily when evaluating them for a design, they are marked with an two-letter abbreviation in column "Symbol":

- **CC**
Such parameters indicate **C**ontroller **C**haracteristics which are a distinctive feature of the TC1793 and must be regarded for a system design.
- **SR**
Such parameters indicate **S**ystem **R**equirements which must provided by the microcontroller system in which the TC1793 designed in.

5.1.2 Pad Driver and Pad Classes Summary

This section gives an overview on the different pad driver classes and its basic characteristics. More details (mainly DC parameters) are defined in the [Section 5.2.1](#).

Table 9 Pad Driver and Pad Classes Overview

Class	Power Supply	Type	Sub Class	Speed Grade	Load	Leakage 150°C	Termination
A	3.3 V	LVTTTL I/O, LVTTTL outputs	A1 (e.g. GPIO)	6 MHz	100 pF	500 nA	No
			A1+ (e.g. serial I/Os)	25 MHz	50 pF	1 μ A	Series termination recommended
			A2 (e.g. serial I/Os)	40 MHz	50 pF	3 μ A	Series termination recommended
B	3.3 V ¹⁾	LVTTTL I/O		75 MHz	35 pF	6 μ A	Series termination recommended
	2.5 V ¹⁾			75 MHz	35 pF		
F	3.3 V	LVDS	–	50 MHz	–	–	Parallel termination, 100 $\Omega \pm 10\%$ ²⁾
		CMOS	–	6 MHz	50 pF	–	
D_E	5 V	ADC	–	–	–	–	
I	3.3 V	LVTTTL (input only)	–	–	–	–	

1) Supplied via V_{DDEBU}.

2) In applications where the LVDS pins are not used (disabled), these pins must be either left unconnected, or properly terminated with the differential parallel termination of 100 $\Omega \pm 10\%$.

Electrical Parameters General Parameters

5.1.3 Absolute Maximum Ratings

Stresses above the values listed under “Absolute Maximum Ratings” may cause permanent damage to the device. This is a stress rating only and functional operation of the device at these or any other conditions above those indicated in the operational sections of this specification is not implied. Exposure to absolute maximum rating conditions may affect device reliability.

Table 10 Absolute Maximum Rating Parameters

Parameter	Symbol	Values			Unit	Note / Test Condition
		Min.	Typ.	Max.		
Storage temperature	T_{ST} SR	-65	–	150	°C	–
Voltage at 1.3 V power supply pins with respect to V_{SS}	V_{DD} SR	–	–	2.0	V	–
Voltage at 3.3 V power supply pins with respect to V_{SS}	V_{DDP} SR	–	–	4.33	V	–
Voltage at 5 V power supply pins with respect to V_{SS}	V_{DDM} SR	–	–	7.0	V	–
Voltage on any Class A input pin and dedicated input pins with respect to V_{SS}	V_{IN} SR	-0.7	–	$V_{DDP} + 0.7$ or max. 4.33	V	Whatever is lower
Voltage on any Class D analog input pin with respect to V_{AGND}	V_{AIN} V_{AREF_x} SR	-0.6	–	7.0	V	–
Voltage on any shared Class D analog input pin with respect to V_{SSAF} , if the FADC is switched through to the pin.	V_{AINF} V_{FAREF} SR	-0.6	–	7.0	V	–
Input current on any pin during overload condition	I_{IN}	-10	–	+10	mA	
Absolute maximum sum of all input circuit currents for one port group during overload condition ¹⁾	I_{IN}	-25	–	+25	mA	
Absolute maximum sum of all input circuit currents during overload condition	ΣI_{IN}	-200	–	200	mA	

- 1) The port groups are defined in [Table 15](#).

5.1.4 Pin Reliability in Overload

When receiving signals from higher voltage devices, low-voltage devices experience overload currents and voltages that go beyond their own IO power supplies specification.

Table 11 defines overload conditions that will not cause any negative reliability impact if all the following conditions are met:

- full operation life-time (24000 h) is not exceeded
- **Operating Conditions** are met for
 - pad supply levels (V_{DDP} , V_{DDM} , or, V_{DDEBU})
 - temperature

If a pin current is out of the **Operating Conditions** but within the overload parameters, then the parameters functionality of this pin as stated in the Operating Conditions can no longer be guaranteed. Operation is still possible in most cases but with relaxed parameters.

Note: An overload condition on one or more pins does not require a reset.

Table 11 Overload Parameters

Parameter	Symbol	Values			Unit	Note / Test Condition
		Min.	Typ.	Max.		
Input current on any digital pin during overload condition except LVDS pins	I_{IN}	-5	–	+5	mA	
Input current on LVDS pins	I_{INLVDS}	-3	–	+3	mA	
Absolute sum of all input circuit currents for one port group during overload condition ¹⁾	I_{ING}	-20	–	+20	mA	
Input current on analog pins	I_{INANA}	-3	–	+3	mA	
Absolute sum of all analog input currents for analog inputs during overload condition	I_{INSA}	-45	–	+45	mA	
Absolute sum of all input circuit currents during overload condition	ΣI_{INS}	-100	–	100	mA	

1) The port groups are defined in **Table 15**.

Note: FADC input pins count as analog pin as they are overlaid with an ADC pins.

Table 12 PN-Junction Characteristics for positive Overload

Pad Type	$I_{IN} = 3 \text{ mA}$	$I_{IN} = 5 \text{ mA}$
A1 / A1+ / F	$U_{IN} = V_{DDP} + 0.6 \text{ V}$	$U_{IN} = V_{DDP} + 0.7 \text{ V}$
A2	$U_{IN} = V_{DDP} + 0.5 \text{ V}$	$U_{IN} = V_{DDP} + 0.6 \text{ V}$
LVDS	$U_{IN} = V_{DDP} + 0.7 \text{ V}$	-
D	$U_{IN} = V_{DDM} + 0.6 \text{ V}$	-
S	$U_{IN} = V_{DDM} + 0.6 \text{ V}$	-

Table 13 PN-Junction Characteristics for negative Overload

Pad Type	$I_{IN} = -3 \text{ mA}$	$I_{IN} = -5 \text{ mA}$
A1 / A1+ / F	$U_{IN} = V_{SS} - 0.6 \text{ V}$	$U_{IN} = V_{SS} - 0.7 \text{ V}$
A2	$U_{IN} = V_{SS} - 0.5 \text{ V}$	$U_{IN} = V_{SS} - 0.6 \text{ V}$
LVDS	$U_{IN} = V_{SS} - 0.7 \text{ V}$	-
D	$U_{IN} = V_{SSM} - 0.6 \text{ V}$	-
S	$U_{IN} = V_{SSM} - 0.6 \text{ V}$	-

Note: A series resistor at the pin to limit the current to the maximum permitted overload current is sufficient to handle failure situations like short to battery without having any negative reliability impact on the operational life-time.

Electrical Parameters General Parameters

5.1.5 Operating Conditions

The following operating conditions must not be exceeded in order to ensure correct operation and reliability of the TC1793. All parameters specified in the following tables refer to these operating conditions, unless otherwise noticed.

Digital supply voltages applied to the TC1793 must be static regulated voltages which allow a typical voltage swing of $\pm 5\%$.

All parameters specified in the following tables ([Table 16](#) and following) refer to these operating conditions ([Table 14](#)), unless otherwise noticed in the Note / Test Condition column.

The [Extended Range Operating Conditions](#) did not increase area of validity of the parameters defined in table 10 and later.

Table 14 Operating Conditions Parameters

Parameter	Symbol	Values			Unit	Note / Test Condition
		Min.	Typ.	Max.		
Overload coupling factor for analog inputs, negative	K_{OVAN} CC	–	–	0.0001		$I_{OV} \leq 0$ mA; $I_{OV} \geq -1$ mA; analog pad= 5.0 V
Overload coupling factor for analog inputs, positive	K_{OVAP} CC	–	–	0.0000 1		$I_{OV} \leq 3$ mA; $I_{OV} \geq 0$ mA; analog pad= 5.0 V
CPU Frequency	f_{CPU} SR	–	–	270	MHz	SAK-TC1793F-512F 270EB; SAK-TC1793F-512F 270EF; SAK-TC1793N-512F 270EF; SAK-TC1793S-512F 270EF
		–	–	200	MHz	SAK-TC1793F-512F 200EF SAK-TC1793F-512F 200EB

Electrical Parameters General Parameters
Table 14 Operating Conditions Parameters (cont'd)

Parameter	Symbol	Values			Unit	Note / Test Condition
		Min.	Typ.	Max.		
Modulated f_{CPU}	$f_{CPU_modulated}$ SR	–	–	270	MHz	SAK-TC1793F-512F 270EB; SAK-TC1793F-512F 270EF; SAK-TC1793N-512F 270EF; SAK-TC1793S-512F 270EF
		–	–	200	MHz	SAK-TC1793F-512F 200EF SAK-TC1793F-512F 200EB
FPI bus frequency	f_{FPI} SR	–	–	100	MHz	
Modulated f_{FPI}	$f_{FPI_modulated}$ SR	–	–	100-2*MA ¹⁾	MHz	MA = modulation amplitude
FSI frequency	f_{FSI} SR	–	–	150	MHz	
Modulated f_{FSI}	$f_{FSI_modulated}$ SR	–	–	150-2*MA ¹⁾	MHz	MA = modulation amplitude
PCP Frequency	f_{PCP} SR	–	–	200	MHz	
Modulated f_{PCP}	$f_{PCP_modulated}$ SR	–	–	200-2*MA ¹⁾	MHz	MA = modulation amplitude
SRI Frequency	f_{SRI} SR	–	–	270	MHz	SAK-TC1793F-512F 270EB; SAK-TC1793F-512F 270EF; SAK-TC1793N-512F 270EF; SAK-TC1793S-512F 270EF
		–	–	200	MHz	SAK-TC1793F-512F 200EF SAK-TC1793F-512F 200EB

Electrical Parameters General Parameters

Table 14 Operating Conditions Parameters (cont'd)

Parameter	Symbol	Values			Unit	Note / Test Condition
		Min.	Typ.	Max.		
Modulated f_{SRI}	$f_{SRI_modulated}$ SR	–	–	270	MHz	SAK-TC1793F-512F 270EB; SAK-TC1793F-512F 270EF; SAK-TC1793N-512F 270EF; SAK-TC1793S-512F 270EF
		–	–	200	MHz	SAK-TC1793F-512F 200EF SAK-TC1793F-512F 200EB
Inactive device pin current	I_{ID} SR	-1	–	1	mA	All power supply voltages $V_{DDx} = 0$
Short circuit current of digital outputs ²⁾	I_{SC} SR	-5	–	5	mA	
Absolute sum of short circuit currents of the device	ΣI_{SC_DCC}	–	–	100	mA	
Absolute sum of short circuit currents per pin group	ΣI_{SC_PGCC}	–	–	20	mA	
Ambient Temperature	T_A SR	-40	–	125	°C	
Junction temperature	T_J SR	-40	–	150	°C	
Core Supply Voltage	V_{DD} SR	1.17	1.3	1.43 ³⁾	V	for duration limitation see Section 5.1.5.1
EBU supply voltage	V_{DDEBU} SR	3.135	3.3	3.47 ⁵⁾	V	
		2.375	2.5	2.625	V	
Flash supply voltage 3.3V	V_{DDFL3} SR	2.97	3.3	3.63 ⁵⁾	V	for duration limitation see Section 5.1.5.1

Electrical Parameters General Parameters

Table 14 Operating Conditions Parameters (cont'd)

Parameter	Symbol	Values			Unit	Note / Test Condition
		Min.	Typ.	Max.		
ADC analog supply voltage	V_{DDM} SR	2.97	5	5.5 ⁴⁾	V	
Oscillator core supply voltage	V_{DDOSC} SR	1.17	1.3	1.43 ³⁾	V	for duration limitation see Section 5.1.5.1
Oscillator 3.3V supply voltage	V_{DDOSC3} SR	2.97	3.3	3.63 ⁵⁾	V	for duration limitation see Section 5.1.5.1
Digital supply voltage for IO pads	V_{DDP} SR	2.97	3.3	3.63 ⁵⁾	V	for duration limitation see Section 5.1.5.1
E-Ray PLL core voltage supply	V_{DDPF} SR	1.17	1.3	1.43 ³⁾	V	for duration limitation see Section 5.1.5.1
E-Ray PLL 3.3V supply	V_{DDPF3} SR	2.97	3.3	3.63 ⁵⁾	V	for duration limitation see Section 5.1.5.1
VDDP voltage to ensure defined pad states ⁶⁾	V_{DDPPA} CC	0.65	–	–	V	
Digital ground voltage	V_{SS} SR	0	–	–	V	
Analog ground voltage for V_{DDM}	V_{SSM} SR	-0.1	0	0.1	V	
Analog core supply	V_{DDAF} SR	1.17	1.3	1.43 ³⁾	V	for duration limitation see Section 5.1.5.1
FADC / ADC analog supply voltage	V_{DDMF} SR	2.97	3.3	3.63 ⁵⁾	V	for duration limitation see Section 5.1.5.1
Analog ground voltage for V_{DDMF}	V_{SSAF} SR	-0.1	0	0.1	V	

1) MA equals the modulation amplitude in percentage times the configured PLL clock out frequency.

2) Applicable for digital outputs.

3) Voltage overshoot to 1.7V is permissible at Power-Up and $\overline{\text{PORST}}$ low, provided the pulse duration is less than 100 μs and the cumulated sum of the pulses does not exceed 1 h.

Electrical Parameters

- 4) Voltage overshoot to 6.5V is permissible at Power-Up and $\overline{\text{PORST}}$ low, provided the pulse duration is less than 100 μs and the cumulated sum of the pulses does not exceed 1 h.
- 5) Voltage overshoot to 4.0V is permissible at Power-Up and $\overline{\text{PORST}}$ low, provided the pulse duration is less than 100 μs and the cumulated sum of the pulses does not exceed 1 h.
- 6) This parameter is valid under the assumption the $\overline{\text{PORST}}$ signal is constantly at low level during the power-up/power-down of V_{DDP} .

5.1.5.1 Extended Range Operating Conditions

The following extended operating conditions are defined:

- $1.3\text{V} + 5\% < V_{\text{DD}} / V_{\text{DDOSC}} / V_{\text{DDPF}} / V_{\text{DDAF}} < 1.3\text{V} + 7.5\%$ (overvoltage condition):
– limited to 10000 hours duration cumulative in lifetime, due to the reliability reduction of the chip caused by the overvoltage stress.
- $1.3\text{V} + 7.5\% < V_{\text{DD}} / V_{\text{DDOSC}} / V_{\text{DDPF}} / V_{\text{DDAF}} < 1.3\text{V} + 10\%$ (overvoltage condition):
– limited to 1000 hours duration cumulative in lifetime, due to the reliability reduction of the chip caused by the overvoltage stress.
- $3.3\text{V} + 5\% < V_{\text{DDP}} / V_{\text{DDOSC3}} / V_{\text{DDPF3}} / V_{\text{DDFL3}} / V_{\text{DDMF}} / V_{\text{DDEBU}} < 3.3\text{V} + 10\%$ (overvoltage condition):
limited to 1000 hours duration cumulative in lifetime, due to the reliability reduction of the chip caused by the overvoltage stress.

Table 15 Pin Groups for Overload / Short-Circuit Current Sum Parameter

Group	Pins
1	P2.[4:2], P6.[6:9]
2	P6.[5:4], P6.[11:10]
3	P6.[15:12]
4	P8.[5:0]
5	P8.[7:6], P1.[15:13]
6	P1.5, P1.[11:8]
7	P1.[4:2], P1.6, P1.12
8	P1.[1:0], P7.[2:0]
9	P7.[7:3]
10	P4.[6:0]
11	P4.[10:7]
12	P4.[15:11]
13	P10.[5:0]
14	P15.[7:4], P16.[1:0]
15	P15.3, P15.[12:11], P16.[5:3]

Table 15 Pin Groups for Overload / Short-Circuit Current Sum Parameter

Group	Pins
16	P15.[2:0], P15.[9:8], P16.2, P16.8
17	P15.10, P15.[15:13], P16.[7:6]
18	P14.[15:12]
19	P14.[11:8], P16.12
20	P14.[7:3], P16.11
21	P13.15, P14.[2:0]
22	P13.[14:11]
23	P13.[10:8], P16.10
24	P13.[7:4], P16.9
25	P12.5, P13.[3:0]
26	P12.[4:0]
27	P11.[15:11]
28	P11.[10:6]
29	P11.[5:2]
30	P11.[1:0], P12.[7:6]
31	P9.10, P9.14
32	P9.7, P9.13
33	P9.[4:2], P9.6
34	P9.1, P9.5, P9.[9:8]
35	P9.0, P9.[12:11]
36	P5.[11:8]
37	P5.6, P5.[15:12]
38	P5.0, P5.[5:2], P5.7
39	P3.[5:0], P5.1
40	P3.[12:6]
41	P0.[3:0], P3.[15:13]
42	P0.[11:4]
43	P0.[14:12]
44	P0.15

Table 15 Pin Groups for Overload / Short-Circuit Current Sum Parameter

Group	Pins
45	P2.[15:11]
46	P2.[10:5]

5.2 DC Parameters

5.2.1 Input/Output Pins

Table 16 Standard_Pads Parameters

Parameter	Symbol	Values			Unit	Note / Test Condition
		Min.	Typ.	Max.		
Pin capacitance (digital inputs/outputs)	C_{IO} CC	–	–	10	pF	$T_A = 25\text{ °C}$; $f = 1\text{ MHz}$
Pull-down current	$ I_{PDL} $ CC	–	–	150	μA	$V_I \geq 0.6 \times V_{DDP}$ V
		10	–	–	μA	$V_I \geq 0.36 \times V_{DDP}$ V
Pull-Up current	$ I_{PUH} $ CC	10	–	–	μA	$V_I \leq 0.6 \times V_{DDP}$ V
		–	–	100	μA	$V_I \leq 0.36 \times V_{DDP}$ V
Spike filter always blocked pulse duration	t_{SF1} CC	–	–	10	ns	only PORST pin
Spike filter pass-through pulse duration	t_{SF2} CC	100	–	–	ns	only PORST pin

Table 17 Standard_Pads Class_A1

Parameter	Symbol	Values			Unit	Note / Test Condition
		Min.	Typ.	Max.		
Input Hysteresis for A1 pads ¹⁾	HYS_{A1} CC	$0.1 \times V_{DDP}$	–	–	V	
Input Leakage Current Class A1	I_{OZA1} CC	-500	–	500	nA	$V_I \geq 0\text{ V}$; $V_I \leq V_{DDP}$ V
Ratio V_{iL}/V_{iH} , A1 pads	V_{iLA1} / V_{iHA1} CC	0.6	–	–		
On-Resistance of the class A1 pad, weak driver	R_{DSONW} CC	–	450	600	Ohm	$I_{OH} > -0.5\text{ mA}$; P_MOS
		–	210	340	Ohm	$I_{OL} < 0.5\text{ mA}$; N_MOS

Electrical Parameters DC Parameters

Table 17 Standard_Pads Class_A1 (cont'd)

Parameter	Symbol	Values			Unit	Note / Test Condition
		Min.	Typ.	Max.		
On-Resistance of the class A1 pad, medium driver	R_{DSONM} CC	–	–	155	Ohm	$I_{OH} > -2$ mA; P_MOS
		–	–	110	Ohm	$I_{OL} < 2$ mA; N_MOS
Fall time, pad type A1	t_{FA1} CC	–	–	150	ns	$C_L = 20$ pF; pin out driver= weak
		–	–	50	ns	$C_L = 50$ pF; pin out driver= medium
		–	–	140	ns	$C_L = 150$ pF; pin out driver= medium
		–	–	550	ns	$C_L = 150$ pF; pin out driver= weak
		–	–	18000	ns	$C_L = 20000$ pF; pin out driver= medium
		–	–	65000	ns	$C_L = 20000$ pF; pin out driver= weak

Electrical Parameters DC Parameters

Table 17 Standard_Pads Class_A1 (cont'd)

Parameter	Symbol	Values			Unit	Note / Test Condition
		Min.	Typ.	Max.		
Rise time, pad type A1	t_{RA1} CC	–	–	150	ns	$C_L = 20$ pF; pin out driver= weak
		–	–	50	ns	$C_L = 50$ pF; pin out driver= medium
		–	–	140	ns	$C_L = 150$ pF; pin out driver= medium
		–	–	550	ns	$C_L = 150$ pF; pin out driver= weak
		–	–	18000	ns	$C_L = 20000$ pF; pin out driver= medium
		–	–	65000	ns	$C_L = 20000$ pF; pin out driver= weak
Input high voltage class A1 pads	V_{IHA1} SR	$0.6 \times V_{DDP}$	–	$\min(V_{DDP} + 0.3, 3.6)$	V	
Input low voltage class A1 pads	V_{ILA1} SR	-0.3	–	$0.36 \times V_{DDP}$	V	

Electrical Parameters DC Parameters

Table 17 Standard_Pads Class_A1 (cont'd)

Parameter	Symbol	Values			Unit	Note / Test Condition
		Min.	Typ.	Max.		
Output voltage high class A1 pads	V_{OHA1} CC	$V_{\text{DDP}} - 0.4$	–	–	V	$I_{\text{OH}} \geq -1.4$ mA; pin out driver= medium
		2.4	–	–	V	$I_{\text{OH}} \geq -2$ mA; pin out driver= medium
		$V_{\text{DDP}} - 0.4$	–	–	V	$I_{\text{OH}} \geq -400$ μ A; pin out driver= weak
		2.4	–	–	V	$I_{\text{OH}} \geq -500$ μ A; pin out driver= weak
Output voltage low class A1 pads	V_{OLA1} CC	–	–	0.4	V	$I_{\text{OL}} \leq 2$ mA; pin out driver= medium
		–	–	0.4	V	$I_{\text{OL}} \leq 500$ μ A; pin out driver= weak

1) Hysteresis is implemented to avoid metastable states and switching due to internal ground bounce. It can't be guaranteed that it suppresses switching due to external system noise.

Table 18 Standard_Pads Class_A1+

Parameter	Symbol	Values			Unit	Note / Test Condition
		Min.	Typ.	Max.		
Input Hysteresis for A1+ pads ¹⁾	H_{YSA1} + CC	$0.1 \times V_{\text{DDP}}$	–	–	V	
Input Leakage Current Class A1+	$I_{\text{OZA1+}}$ CC	-1000	–	1000	nA	
On-Resistance of the class A1+ pad, weak driver	R_{DSONW} CC	–	450	600	Ohm	$I_{\text{OH}} > -0.5$ mA; P_MOS
		–	210	340	Ohm	$I_{\text{OL}} < 0.5$ mA; N_MOS

Electrical Parameters DC Parameters

Table 18 Standard_Pads Class_A1+ (cont'd)

Parameter	Symbol	Values			Unit	Note / Test Condition
		Min.	Typ.	Max.		
On-Resistance of the class A1+ pad, medium driver	R_{DSONM} CC	–	–	155	Ohm	$I_{OH} > -2$ mA; P_MOS
		–	–	110	Ohm	$I_{OL} < 2$ mA; N_MOS
On-Resistance of the class A1+ pad, strong driver	R_{DSON1+} CC	–	–	100	Ohm	$I_{OH} > -2$ mA; P_MOS
		–	–	80	Ohm	$I_{OL} < 2$ mA; N_MOS
Fall time, pad type A1+	t_{FA1+} CC	–	–	150	ns	$C_L = 20$ pF; pin out driver= weak
		–	–	28	ns	$C_L = 50$ pF; edge= slow ; pin out driver= strong
		–	–	16	ns	$C_L = 50$ pF; edge= soft ; pin out driver= strong
		–	–	50	ns	$C_L = 50$ pF; pin out driver= medium
		–	–	140	ns	$C_L = 150$ pF; pin out driver= medium
		–	–	550	ns	$C_L = 150$ pF; pin out driver= weak
		–	–	18000	ns	$C_L = 20000$ pF; pin out driver= medium
		–	–	65000	ns	$C_L = 20000$ pF; pin out driver= weak

Electrical Parameters DC Parameters

Table 18 Standard_Pads Class_A1+ (cont'd)

Parameter	Symbol	Values			Unit	Note / Test Condition
		Min.	Typ.	Max.		
Rise time, pad type A1+	t_{RA1+} CC	–	–	150	ns	$C_L = 20$ pF; pin out driver= weak
		–	–	28	ns	$C_L = 50$ pF; edge= slow ; pin out driver= strong
		–	–	16	ns	$C_L = 50$ pF; edge= soft ; pin out driver= strong
		–	–	50	ns	$C_L = 50$ pF; pin out driver= medium
		–	–	140	ns	$C_L = 150$ pF; pin out driver= medium
		–	–	550	ns	$C_L = 150$ pF; pin out driver= weak
		–	–	18000	ns	$C_L = 20000$ pF; pin out driver= medium
		–	–	65000	ns	$C_L = 20000$ pF; pin out driver= weak
Input high voltage, Class A1+ pads	V_{IHA1+} SR	$0.6 \times V_{DDP}$	–	$\min(V_{DDP} + 0.3, 3.6)$	V	
Input low voltage Class A1+ pads	V_{ILA1+} SR	-0.3	–	$0.36 \times V_{DDP}$	V	
Ratio V_{il}/V_{ih} , A1+ pads	V_{ILA1+} / V_{IHA1+} CC	0.6	–	–		

Electrical Parameters DC Parameters

Table 18 Standard_Pads Class_A1+ (cont'd)

Parameter	Symbol	Values			Unit	Note / Test Condition
		Min.	Typ.	Max.		
Output voltage high class A1+ pads	$V_{\text{OHA1+CC}}$	$V_{\text{DDP}} - 0.4$	—	—	V	$I_{\text{OH}} \geq -1.4 \text{ mA}$; pin out driver= medium
		$V_{\text{DDP}} - 0.4$	—	—	V	$I_{\text{OH}} \geq -1.4 \text{ mA}$; pin out driver= strong
		2.4	—	—	V	$I_{\text{OH}} \geq -2 \text{ mA}$; pin out driver= medium
		2.4	—	—	V	$I_{\text{OH}} \geq -2 \text{ mA}$; pin out driver= strong
		$V_{\text{DDP}} - 0.4$	—	—	V	$I_{\text{OH}} \geq -400 \mu\text{A}$; pin out driver= weak
		2.4	—	—	V	$I_{\text{OH}} \geq -500 \mu\text{A}$; pin out driver= weak
Output voltage low class A1+ pads	$V_{\text{OLA1+CC}}$	—	—	0.4	V	$I_{\text{OL}} \leq 2 \text{ mA}$; pin out driver= medium
		—	—	0.4	V	$I_{\text{OL}} \leq 2 \text{ mA}$; pin out driver= strong
		—	—	0.4	V	$I_{\text{OL}} \leq 500 \mu\text{A}$; pin out driver= weak

1) Hysteresis is implemented to avoid metastable states and switching due to internal ground bounce. It can't be guaranteed that it suppresses switching due to external system noise.

Electrical Parameters DC Parameters

Table 19 Standard_Pads Class_A2

Parameter	Symbol	Values			Unit	Note / Test Condition
		Min.	Typ.	Max.		
Input Hysteresis for A2 pads ¹⁾	$H Y S A 2$ CC	$0.1 \times V_{DDP}$	–	–	V	
Input Leakage current Class A2	$I_{O Z A 2}$ CC	-6000	–	6000	nA	$V_i < V_{DDP} / 2 - 1 \text{ V}; V_i > V_{DDP} / 2 + 1 \text{ V}; V_i \geq 0 \text{ V}; V_i \leq V_{DDP} \text{ V}$
		-3000	–	3000	nA	$V_i > V_{DDP} / 2 - 1 \text{ V}; V_i < V_{DDP} / 2 + 1 \text{ V}$
Ratio V_{il}/V_{ih} , A2 pads	$V_{I L A 2} / V_{I H A 2}$ CC	0.6	–	–		
On-Resistance of the class A2 pad, weak driver	$R_{D S O N W}$ CC	–	450	600	Ohm	$I_{OH} > -0.5 \text{ mA}; P_MOS$
		–	210	340	Ohm	$I_{OL} < 0.5 \text{ mA}; N_MOS$
On-Resistance of the class A2 pad, medium driver	$R_{D S O N M}$ CC	–	–	155	Ohm	$I_{OH} > -2 \text{ mA}; P_MOS$
		–	–	110	Ohm	$I_{OL} < 2 \text{ mA}; N_MOS$
On-Resistance of the class A2 pad, strong driver	$R_{D S O N 2}$ CC	–	–	28	Ohm	$I_{OH} > -2 \text{ mA}; P_MOS$
		–	–	22	Ohm	$I_{OL} < 2 \text{ mA}; N_MOS$

Electrical Parameters DC Parameters

Table 19 Standard_Pads Class_A2 (cont'd)

Parameter	Symbol	Values			Unit	Note / Test Condition
		Min.	Typ.	Max.		
Fall time, pad type A2	$t_{FA2\ CC}$	–	–	150	ns	$C_L = 20\ \text{pF}$; pin out driver= weak
		–	–	7	ns	$C_L = 50\ \text{pF}$; edge= medium ; pin out driver= strong
		–	–	10	ns	$C_L = 50\ \text{pF}$; edge= medium-minus ; pin out driver= strong
		–	–	3.7	ns	$C_L = 50\ \text{pF}$; edge= sharp ; pin out driver= strong
		–	–	5	ns	$C_L = 50\ \text{pF}$; edge= sharp-minus ; pin out driver= strong
		–	–	16	ns	$C_L = 50\ \text{pF}$; edge= soft ; pin out driver= strong
		–	–	50	ns	$C_L = 50\ \text{pF}$; pin out driver= medium
		–	–	7.5	ns	$C_L = 100\ \text{pF}$; edge= sharp ; pin out driver= strong
		–	–	140	ns	$C_L = 150\ \text{pF}$; pin out driver= medium

Electrical Parameters DC Parameters

Table 19 Standard_Pads Class_A2 (cont'd)

Parameter	Symbol	Values			Unit	Note / Test Condition
		Min.	Typ.	Max.		
		–	–	550	ns	$C_L = 150 \text{ pF}$; pin out driver= weak
		–	–	18000	ns	$C_L = 20000 \text{ pF}$; pin out driver= medium
		–	–	65000	ns	$C_L = 20000 \text{ pF}$; pin out driver= weak

Electrical Parameters DC Parameters

Table 19 Standard_Pads Class_A2 (cont'd)

Parameter	Symbol	Values			Unit	Note / Test Condition
		Min.	Typ.	Max.		
Rise time, pad type A2	$t_{RA2\ CC}$	–	–	150	ns	$C_L = 20\ \text{pF}$; pin out driver= weak
		–	–	7.0	ns	$C_L = 50\ \text{pF}$; edge= medium ; pin out driver= strong
		–	–	10	ns	$C_L = 50\ \text{pF}$; edge= medium-minus ; pin out driver= strong
		–	–	3.7	ns	$C_L = 50\ \text{pF}$; edge= sharp ; pin out driver= strong
		–	–	5	ns	$C_L = 50\ \text{pF}$; edge= sharp-minus ; pin out driver= strong
		–	–	16	ns	$C_L = 50\ \text{pF}$; edge= soft ; pin out driver= strong
		–	–	50	ns	$C_L = 50\ \text{pF}$; pin out driver= medium
		–	–	7.5	ns	$C_L = 100\ \text{pF}$; edge= sharp ; pin out driver= strong
		–	–	140	ns	$C_L = 150\ \text{pF}$; pin out driver= medium

Electrical Parameters DC Parameters

Table 19 Standard_Pads Class_A2 (cont'd)

Parameter	Symbol	Values			Unit	Note / Test Condition
		Min.	Typ.	Max.		
		–	–	550	ns	$C_L = 150 \text{ pF}$; pin out driver= weak
		–	–	18000	ns	$C_L = 20000 \text{ pF}$; pin out driver= medium
		–	–	65000	ns	$C_L = 20000 \text{ pF}$; pin out driver= weak
Input high voltage, class A2 pads	V_{IHA2} SR	$0.6 \times V_{DDP}$	–	$\min(V_{DDP} + 0.3, 3.6)$	V	
Input low voltage Class A2 pads	V_{ILA2} SR	-0.3	–	$0.36 \times V_{DDP}$	V	
Output voltage high class A2 pads	V_{OHA2} CC	$V_{DDP} - 0.4$	–	–	V	$I_{OH} \geq -1.4 \text{ mA}$; pin out driver= medium
		$V_{DDP} - 0.4$	–	–	V	$I_{OH} \geq -1.4 \text{ mA}$; pin out driver= strong
		2.4	–	–	V	$I_{OH} \geq -2 \text{ mA}$; pin out driver= medium
		2.4	–	–	V	$I_{OH} \geq -2 \text{ mA}$; pin out driver= strong
		$V_{DDP} - 0.4$	–	–	V	$I_{OH} \geq -400 \text{ }\mu\text{A}$; pin out driver= weak
		2.4	–	–	V	$I_{OH} \geq -500 \text{ }\mu\text{A}$; pin out driver= weak

Electrical Parameters DC Parameters

Table 19 Standard_Pads Class_A2 (cont'd)

Parameter	Symbol	Values			Unit	Note / Test Condition
		Min.	Typ.	Max.		
Output voltage low class A2 pads	V_{OLA2} CC	–	–	0.4	V	$I_{OL} \leq 2$ mA; pin out driver= medium
		–	–	0.4	V	$I_{OL} \leq 2$ mA; pin out driver= strong
		–	–	0.4	V	$I_{OL} \leq 500$ μ A; pin out driver= weak

1) Hysteresis is implemented to avoid metastable states and switching due to internal ground bounce. It can't be guaranteed that it suppresses switching due to external system noise.

Table 20 Standard_Pads Class_B

Parameter	Symbol	Values			Unit	Note / Test Condition
		Min.	Typ.	Max.		
Input Hysteresis, B class pads ¹⁾	$HYSB$ CC	$0.08 \times V_{DDEBU}$	–	–	V	$V_{DDEBU} = 2.5$ V
		$0.1 \times V_{DDEBU}$	–	–	V	$V_{DDEBU} = 3.3$ V
Input Leakage Current, class B pads	I_{OZB} CC	-6000	–	6000	nA	else
		-3000	–	3000	nA	$(V_{DDEBU}/2 - 0.6$ V) < V_i < ($V_{DDEBU}/2 + 0.6$ V)
Ratio between low and high input threshold	V_{ILB} / V_{IHB} CC	0.6	–	–		
On-Resistance of the class B pad, weak driver	R_{DSONW} CC	–	450	600	Ohm	$I_{OH} > -0.5$ mA; P_MOS
		–	210	340	Ohm	$I_{OL} < 0.5$ mA; N_MOS
On-Resistance of the class B pad, medium driver	R_{DSONM} CC	–	–	155	Ohm	$I_{OH} > -2$ mA; P_MOS
		–	–	110	Ohm	$I_{OL} < 2$ mA; N_MOS

Electrical Parameters DC Parameters

Table 20 Standard_Pads Class_B (cont'd)

Parameter	Symbol	Values			Unit	Note / Test Condition
		Min.	Typ.	Max.		
On-Resistance of the class B pad, strong driver	R_{DSON2} CC	–	–	28	Ohm	$I_{\text{OH}} > -2 \text{ mA}$; P_MOS
		–	–	22	Ohm	$I_{\text{OL}} < 2 \text{ mA}$; N_MOS
Fall time, class B pads; edge= sharp ; pin out driver= strong ²⁾	t_{FB} CC	–	–	3.7	ns	$C_{\text{L}} = 35 \text{ pF}$; $V_{\text{DDEBU}} > 2.375$; $V_{\text{DDEBU}} \leq 2.625$
		–	–	3.0	ns	$C_{\text{L}} = 35 \text{ pF}$; $V_{\text{DDEBU}} > 3.13$; $V_{\text{DDEBU}} \leq 3.47$
		–	–	4.6	ns	$C_{\text{L}} = 50 \text{ pF}$; $V_{\text{DDEBU}} > 2.375$; $V_{\text{DDEBU}} \leq 2.625$
		–	–	3.7	ns	$C_{\text{L}} = 50 \text{ pF}$; $V_{\text{DDEBU}} > 3.13$; $V_{\text{DDEBU}} \leq 3.47$
		–	–	9.0	ns	$C_{\text{L}} = 100 \text{ pF}$; $V_{\text{DDEBU}} > 2.375$; $V_{\text{DDEBU}} \leq 2.625$
		–	–	7.5	ns	$C_{\text{L}} = 100 \text{ pF}$; $V_{\text{DDEBU}} > 3.13$; $V_{\text{DDEBU}} \leq 3.47$

Electrical Parameters DC Parameters

Table 20 Standard_Pads Class_B (cont'd)

Parameter	Symbol	Values			Unit	Note / Test Condition
		Min.	Typ.	Max.		
Rise time, class B pads; edge= sharp ; pin out driver= strong ²⁾	t_{RB} CC	–	–	3.7	ns	$C_L = 35$ pF; $V_{DDEBU} > 2.375$; $V_{DDEBU} \leq 2.625$
		–	–	3.0	ns	$C_L = 35$ pF; $V_{DDEBU} > 3.13$; $V_{DDEBU} \leq 3.47$
		–	–	4.6	ns	$C_L = 50$ pF; $V_{DDEBU} > 2.375$; $V_{DDEBU} \leq 2.625$
		–	–	3.7	ns	$C_L = 50$ pF; $V_{DDEBU} > 3.13$; $V_{DDEBU} \leq 3.47$
		–	–	9.0	ns	$C_L = 100$ pF; $V_{DDEBU} > 2.375$; $V_{DDEBU} \leq 2.625$
		–	–	7.5	ns	$C_L = 100$ pF; $V_{DDEBU} > 3.13$; $V_{DDEBU} \leq 3.47$
Input high voltage, class B pads	V_{IHB} CC	$0.6 \times V_{DDEBU}$	–	$max(V_{DDEBU} + 0.3, 3.6)$	V	
Input low voltage, Class B pads	V_{ILB} CC	-0.3	–	$0.36 \times V_{DDEBU}$	V	
Output voltage high, class B pads	V_{OHB} CC	$V_{DDEBU} - 0.4$	–	–	V	$I_{OH} = -2$ mA; $V_{DDEBU} > 2.375$ V; $V_{DDEBU} \leq 3.47$ V
Output voltage low, class B pads	V_{OLB} CC	–	–	0.4	V	$I_{OL} = 2$ mA

1) Hysteresis is implemented to avoid metastable states and switching due to internal ground bounce. It can't be guaranteed that it suppresses switching due to external system noise.

2) For non strong driver and sharp edge settings see the class A2 definitions.

Electrical Parameters DC Parameters

Table 21 Standard_Pads Class_F

Parameter	Symbol	Values			Unit	Note / Test Condition
		Min.	Typ.	Max.		
Input Hysteresis F ¹⁾	$HYSF$ CC	$0.05 \times V_{DDP}$	–	–	V	
Input Leakage Current Class F	I_{OZF} CC	–6000	–	6000	nA	$V_i < V_{DDP} / 2 - 1$ V; $V_i > V_{DDP} / 2 + 1$ V; $V_i \geq 0$ V; $V_i \leq V_{DDP}$ V
		–3000	–	3000	nA	$V_i > V_{DDP} / 2 - 1$ V; $V_i < V_{DDP} / 2 + 1$ V
Ratio V_{il}/V_{ih} , F pads	V_{ILF} / V_{IHF} CC	0.6	–	–		
On-Resistance of the class F pad, medium driver	R_{DSONM} CC	–	–	170	Ohm	$I_{OH} > -2$ mA; P_MOS
		–	–	145	Ohm	$I_{OL} < 2$ mA; N_MOS
Fall time, pad type F, CMOS mode	t_{FF} CC	–	–	60	ns	$C_L = 50$ pF
Rise time, pad type F, CMOS mode	t_{RF} CC	–	–	60	ns	$C_L = 50$ pF
Input high voltage, pad class F, CMOS mode	V_{IHF} SR	$0.6 \times V_{DDP}$	–	$\min(V_{DDP+}, 0.3, 3.6)$	V	
Input low voltage, Class F pads, CMOS mode	V_{ILF} SR	–0.3	–	$0.36 \times V_{DDP}$	V	
Output high voltage, class F pads, CMOS mode	V_{OHF} CC	V_{DDP-}	–	–	V	$I_{OH} \geq -1.4$ mA
		0.4 2.4	–	–	V	$I_{OH} \geq -2$ mA
Output low voltage, class F pads, CMOS mode	V_{OLF} CC	–	–	0.4	V	$I_{OL} \leq 2$ mA

1) Hysteresis is implemented to avoid metastable states and switching due to internal ground bounce. It can't be guaranteed that it suppresses switching due to external system noise.

Electrical Parameters DC Parameters

Table 22 Standard_Pads Class_I

Parameter	Symbol	Values			Unit	Note / Test Condition
		Min.	Typ.	Max.		
Input Hysteresis Class I ¹⁾	$HYSI$ CC	$0.1 \times V_{DDP}$	–	–	V	
Input Leakage Current	I_{OZI} CC	-1000	–	1000	nA	
Ratio between low and high input threshold	V_{ILI} / V_{IHI} CC	0.6	–	–		
Input high voltage, class I pins	V_{IHI} SR	$0.6 \times V_{DDP}$	–	$\min(V_{DDP} + 0.3, 3.6)$	V	
Input low voltage, Class I pads	V_{ILI} SR	-0.3	–	$0.36 \times V_{DDP}$	V	

1) Hysteresis is implemented to avoid metastable states and switching due to internal ground bounce. It can't be guaranteed that it suppresses switching due to external system noise.

Class S pad parameters are only valid for $V_{DDM} = 4.75 \text{ V}$ to 5.25 V .

Table 23 Standard_Pads Class_S

Parameter	Symbol	Values			Unit	Note / Test Condition
		Min.	Typ.	Max.		
Input Hysteresis for class S pads ¹⁾	$HYSS$ CC	0.3	–	–	V	
Input leakage current	I_{OZS} CC	-300	–	300	nA	
Input voltage high	V_{IHS} CC	–	–	3.6	V	
Input voltage low	V_{ILS} CC	2.1	–	–	V	
V_{ILS} Delta ²⁾	V_{ILSD} CC	-50	–	50	mV	Maximum input low state threshold variation over 1ms ($V_{DDP} = \text{constant}$)

1) Hysteresis is implemented to avoid metastable states and switching due to internal ground bounce. It can't be guaranteed that it suppresses switching due to external system noise.

Electrical Parameters DC Parameters

2) V_{ILSD} is implemented to ensure J2716 specification. It can't be guaranteed that it suppresses switching due to external noise.

Table 24 LVDS_Pads Parameters

Parameter	Symbol	Values			Unit	Note / Test Condition
		Min.	Typ.	Max.		
Output impedance, pad class F, LVDS mode	R_O CC	40	–	140	Ohm	
Fall time, pad type LVDS	t_{FL} CC	–	–	2	ns	termination 100 $\Omega \pm 1$ %
Rise time, pad type LVDS	t_{RL} CC	–	–	2	ns	termination 100 $\Omega \pm 1$ %
Pad set-up time	t_{SET_LVD} S CC	–	–	13	μ s	termination 100 $\Omega \pm 1$ %
Output Differential Voltage	V_{OD} CC	150	–	400	mV	termination 100 $\Omega \pm 1$ %
Output voltage high, pad class F, LVDS mode	V_{OH} CC	–	–	1525	mV	termination 100 $\Omega \pm 1$ %
Output voltage low, pad class F, LVDS mode	V_{OL} CC	875	–	–	mV	termination 100 $\Omega \pm 1$ %
Output Offset Voltage	V_{OS} CC	1075	–	1325	mV	termination 100 $\Omega \pm 1$ %

Electrical Parameters DC Parameters

5.2.2 Analog to Digital Converters (ADCx)

ADC parameter are valid for $V_{DD} / V_{DDAF} = 1.235 \text{ V to } 1.365 \text{ V}$; $V_{DDM} = 4.5 \text{ V to } 5.5 \text{ V}$.

Table 25 ADC Parameters

Parameter	Symbol	Values			Unit	Note / Test Condition
		Min.	Typ.	Max.		
Switched capacitance at the analog voltage inputs ¹⁾	C_{AINSW} CC	–	9	20	pF	
Total capacitance of an analog input	C_{AINTOT} CC	–	20	30	pF	
Switched capacitance at the positive reference voltage input ²⁾⁽³⁾	C_{AREFSW} CC	–	15	30	pF	
Total capacitance of the voltage reference inputs ²⁾	C_{AREFTO} T CC	–	20	40	pF	
Differential Non-Linearity Error ⁴⁾⁽⁵⁾⁽⁶⁾⁽⁷⁾	EA_{DNL} CC	-3	–	3	LSB	ADC resolution= 12-bit ^{8) 9)}
Gain Error ⁴⁾⁽⁵⁾⁽⁶⁾⁽⁷⁾	EA_{GAIN} CC	-3.5	–	3.5	LSB	ADC resolution= 12-bit ^{8) 9)}
Integral Non-Linearity ⁴⁾⁽⁵⁾⁽⁷⁾⁽⁷⁾	EA_{INL} CC	-3	–	3	LSB	ADC resolution= 12-bit ^{8) 9)}
Offset Error ⁴⁾⁽⁵⁾⁽⁶⁾⁽⁷⁾	EA_{OFF} CC	-4	–	4	LSB	ADC resolution= 12-bit ^{8) 9)}
Converter clock	f_{ADC} SR	4	–	100	MHz	$f_{ADC} = f_{FPI}$
Internal ADC clock	f_{ADCI} CC	1	–	18	MHz	ADC0
		1	–	18	MHz	ADC1
		1	–	20 ¹⁰⁾	MHz	ADC2
Charge consumption per conversion	Q_{CONV} CC	70	85 ¹¹⁾	100	pC	charge needs to be provided via V_{AREF0}

Electrical Parameters DC Parameters

Table 25 ADC Parameters (cont'd)

Parameter	Symbol	Values			Unit	Note / Test Condition
		Min.	Typ.	Max.		
Input leakage at analog inputs ¹²⁾	I_{OZ1} CC	-100	–	500	nA	$V_i \leq V_{DDM}$ V; $V_i \geq 0.97 \times V_{DDM}$ V; overlaid= No
		-100	–	600	nA	$V_i \geq 0.97 \times V_{DDM}$ V; $V_i \leq V_{DDM}$ V; overlaid= Yes
		-500	–	100	nA	$V_i \leq 0.03 \times V_{DDM}$ V; $V_i \geq 0$ V; overlaid= No
		-600	–	100	nA	$V_i \leq 0.03 \times V_{DDM}$ V; $V_i \geq 0$ V; overlaid= Yes
		-100	–	200	nA	$V_i > 0.03 \times V_{DDM}$ V; $V_i < 0.97 \times V_{DDM}$ V; overlaid= No
		-100	–	300	nA	$V_i < 0.97 \times V_{DDM}$ V; $V_i > 0.03 \times V_{DDM}$ V; overlaid= Yes
		Input leakage current at V_{AREF0} / V_{AREF2}	I_{OZ2} CC	-1	–	1
Input leakage current at V_{AREF1}	-2	–		2	μ A	$V_{AREFx} \geq 0$ V; $V_{AREFx} \leq V_{DDM}$ V
Input leakage current at V_{AGNDx}	I_{OZ3} CC	-2	–	2	μ A	$V_{AGNDx} \geq 0$ V; $V_{AGNDx} \leq V_{DDM}$ V
ON resistance of the transmission gates in the analog voltage path	R_{AIN} CC	–	900	1500	Ohm	

Electrical Parameters DC Parameters

Table 25 ADC Parameters (cont'd)

Parameter	Symbol	Values			Unit	Note / Test Condition
		Min.	Typ.	Max.		
ON resistance for the ADC test (pull down for AIN7)	R_{AIN7T} CC	180	550	900	Ohm	
Resistance of the reference voltage input path	R_{AREF} CC	–	500	1000	Ohm	
Sample time	t_S CC	2	–	257	T_{ADCI}	
Calibration time after bit ADC_GLOB_CFG.SUCAL is set	t_{CAL} CC	–	–	4352	cycle s	
Total Unadjusted Error ⁶⁾⁵⁾¹³⁾	TUE CC	-4	–	4 ¹⁴⁾	LSB	ADC resolution= 12-bit
Analog reference ground ²⁾	V_{AGND0} SR	$V_{SSM} - 0.05$	–	$V_{AREF_x} - 1$	V	
Analog input voltage	V_{AIN} SR	V_{AGND_x}	–	V_{AREF_x}	V	
Analog reference voltage ²⁾	V_{AREF_x} SR	$V_{AGND_x} + 1$	–	$V_{DDM} + 0.05$ ¹⁵⁾ ¹⁶⁾	V	
Analog reference voltage range ⁶⁾⁵⁾²⁾	$V_{AREF_x} - V_{AGND_x}$ SR	$V_{DDM}/2$	–	$V_{DDM} + 0.05$	V	

- 1) The sampling capacity of the conversion C-network is pre-charged to $V_{AREF}/2$ before the sampling moment. Because of the parasitic elements the voltage measured at AINx can deviate from $V_{AREF}/2$.
- 2) Applies to AINx, when used as auxiliary reference input.
- 3) This represents an equivalent switched capacitance. This capacitance is not switched to the reference voltage at once. Instead smaller capacitances are successively switched to the reference voltage.
- 4) The sum of DNL/INL/GAIN/OFF errors does not exceed the related TUE total unadjusted error.
- 5) If a reduced analog reference voltage between 1V and $V_{DDM}/2$ is used, then there are additional decrease in the ADC speed and accuracy.
- 6) If the analog reference voltage range is below V_{DDM} but still in the defined range of $V_{DDM}/2$ and V_{DDM} is used, then the ADC converter errors increase. If the reference voltage is reduced by the factor k ($k < 1$), TUE, DNL, INL, Gain, and Offset errors increase also by the factor 1/k.
- 7) If the analog reference voltage is $> V_{DDM}$, then the ADC converter errors increase.
- 8) For 10-bit conversions the error value must be multiplied with a factor 0.25.
- 9) For 8-bit conversions the error value must be multiplied with a factor 0.0625.
- 10) For f_{ADCI} between 18MHz and 20MHz the TUE and Gain Error can increase beyond the given limits. For $STC < 2$ INL, DNL, and Offset errors can also increase.

Electrical Parameters DC Parameters

- 11) For a conversion time of 1 μ s a rms value of 85 μ A result for I_{AREF0} .
- 12) The leakage current definition is a continuous function, as shown in figure ADCx Analoge Input Leakage. The numerical values defined determine the characteristic points of the given continuous linear approximation - they do not define step function.
- 13) Measured without noise.
- 14) For 10-bit conversion the TUE is ± 2 LSB; for 8-bit conversion the TUE is ± 1 LSB
- 15) A running conversion may become inexact in case of violating the normal conditions (voltage overshoot).
- 16) If the reference voltage V_{AREF} increase or the V_{DDM} decrease, so that $V_{AREF} = (V_{DDM} + 0.05V \text{ to } V_{DDM} + 0.07V)$, then the accuracy of the ADC decrease by 4LSB12.

Table 26 Conversion Time (Operating Conditions apply)

Parameter	Symbol	Values	Unit	Note
Conversion time with post-calibration	t_C CC	$2 \times T_{ADC} + (4 + STC + n) \times T_{ADCI}$	μ s	$n = 8, 10, 12$ for n - bit conversion $T_{ADC} = 1 / f_{FPI}$ $T_{ADCI} = 1 / f_{ADCI}$
Conversion time without post-calibration		$2 \times T_{ADC} + (2 + STC + n) \times T_{ADCI}$		

The power-up calibration of the ADC requires a maximum number of 4352 f_{ADCI} cycles.

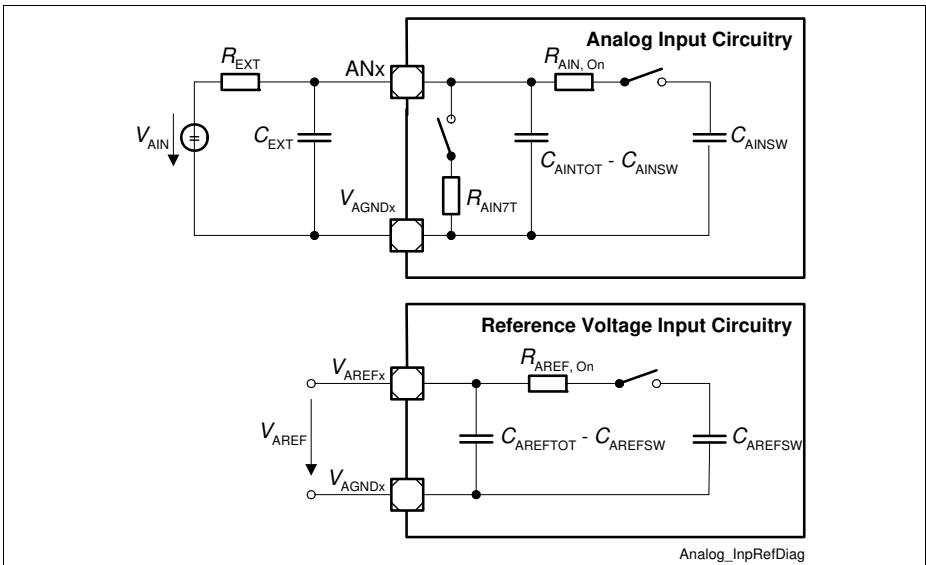

Figure 5 ADCx Input Circuits

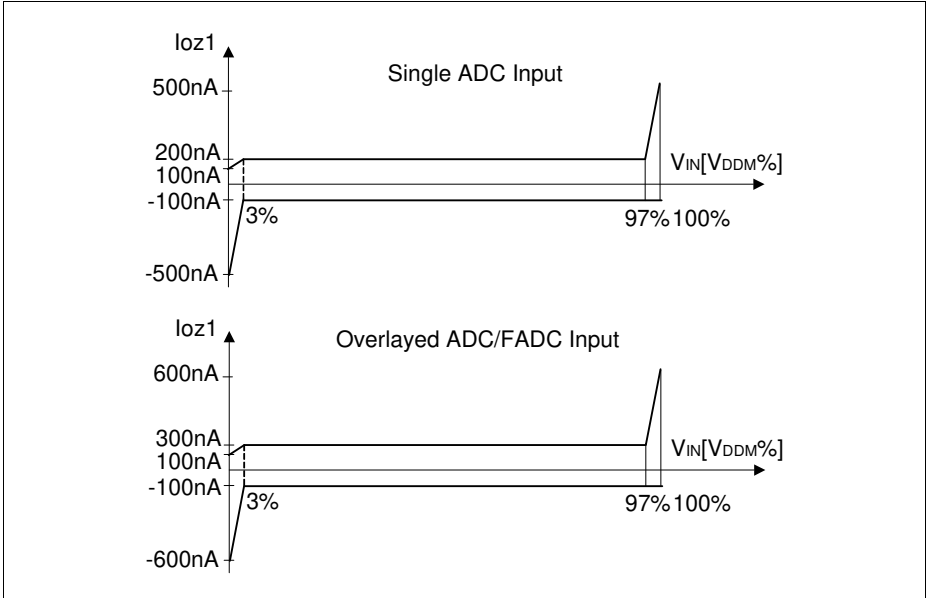

Figure 6 ADCx Analog Inputs Leakage

Electrical Parameters DC Parameters

5.2.3 Fast Analog to Digital Converter (FADC)

FADC parameter are valid for $V_{DD/DDAF} = 1.235\text{ V to }1.365\text{ V}$; $V_{DDMF} = 2.97\text{ V to }3.6\text{ V}$.

Table 27 FADC Parameters

Parameter	Symbol	Values			Unit	Note / Test Condition
		Min.	Typ.	Max.		
Input current at VFAREF	I_{FAREF} CC	–	–	120	μA	
Input leakage current at VFAREF ¹⁾	I_{FOZ2} CC	-500	–	500	nA	$V_{FAREF} \leq V_{DDMF}$ V ; $V_{FAREF} \geq 0\text{ V}$
Input leakage current at VFAGND	I_{FOZ3} CC	-500	–	500	nA	
DNL error	EF_{DNL} CC	-1	–	1	LSB	V_{IN} mode= differential; Gain = 1 or 2
		-2	–	2	LSB	V_{IN} mode= differential; Gain = 4 or 8 ²⁾
		-1	–	1	LSB	V_{IN} mode= single ended; Gain = 1 or 2
		-2	–	2	LSB	V_{IN} mode= single ended; Gain = 4 or 8 ²⁾
GRADient error	EF_{GRAD} CC	-5	–	5	%	V_{IN} mode= differential ; Gain ≤ 4
		-5	–	5	%	V_{IN} mode= single ended ; Gain ≤ 4
		-6	–	6	%	V_{IN} mode= differential ; Gain= 8
		-6	–	6	%	V_{IN} mode= single ended ; Gain= 8

Electrical Parameters DC Parameters

Table 27 FADC Parameters (cont'd)

Parameter	Symbol	Values			Unit	Note / Test Condition
		Min.	Typ.	Max.		
INL error	EF_{INL} CC	-4	–	4	LSB	V_{IN} mode= differential
		-4	–	4	LSB	V_{IN} mode= single ended
Offset error	EF_{OFF} CC	-90	–	90	mV	V_{IN} mode= differential ; Calibration= No
		-90	–	90	mV	V_{IN} mode= single ended ; Calibration= No
		-20	–	20	mV	V_{IN} mode= differential ; Calibration= Yes ³⁾⁴⁾
		-20	–	20	mV	V_{IN} mode= single ended ; Calibration= Yes ³⁾⁴⁾
Error of common mode voltage $V_{\text{FAREF}}/2$	EF_{REF} CC	-60	–	60	mV	
Channel amplifier cutoff frequency	f_{COFF} CC	2	–	–	MHz	
Converter clock	f_{FADC} SR	1	–	100	MHz	$f_{\text{FADC}} = f_{\text{FPI}}$
Conversion time	t_{C} CC	–	–	21	1 / f_{FADC}	For 10-bit conversion
Input resistance of the analog voltage path (Rn, Rp)	R_{FAIN} CC	100	–	200	kOhm	
Settling time of a channel amplifier after changing ENN or ENP	t_{SET} CC	–	–	5	μs	
Analog input voltage range	V_{AINF} SR	V_{FAGND}	–	V_{DDMF}	V	

Electrical Parameters DC Parameters

Table 27 FADC Parameters (cont'd)

Parameter	Symbol	Values			Unit	Note / Test Condition
		Min.	Typ.	Max.		
Analog reference ground	V_{FAGND} SR	$V_{SSAF} - 0.05$	–	$V_{SSAF} + 0.05$	V	
Analog reference voltage	V_{FAREF} SR	3.0	–	$3.63^{5)}$ $6)$	V	

- 1) This value applies in power-down mode.
- 2) No missing codes.
- 3) Calibration should be performed at each power-up. In case of a continuous operation, it should be performed minimum once per week.
- 4) The offset error voltage drifts over the whole temperature range maximum ± 3 LSB.
- 5) Voltage overshoot to 4V is permissible, provided the pulse duration is less than 100 μ s and the cumulated sum of the pulses does not exceed 1 h.
- 6) A running conversion may become inexact in case of violating the normal operating conditions (voltage overshoots).

The calibration procedure should run after each power-up, when all power supply voltages and the reference voltage have stabilized.

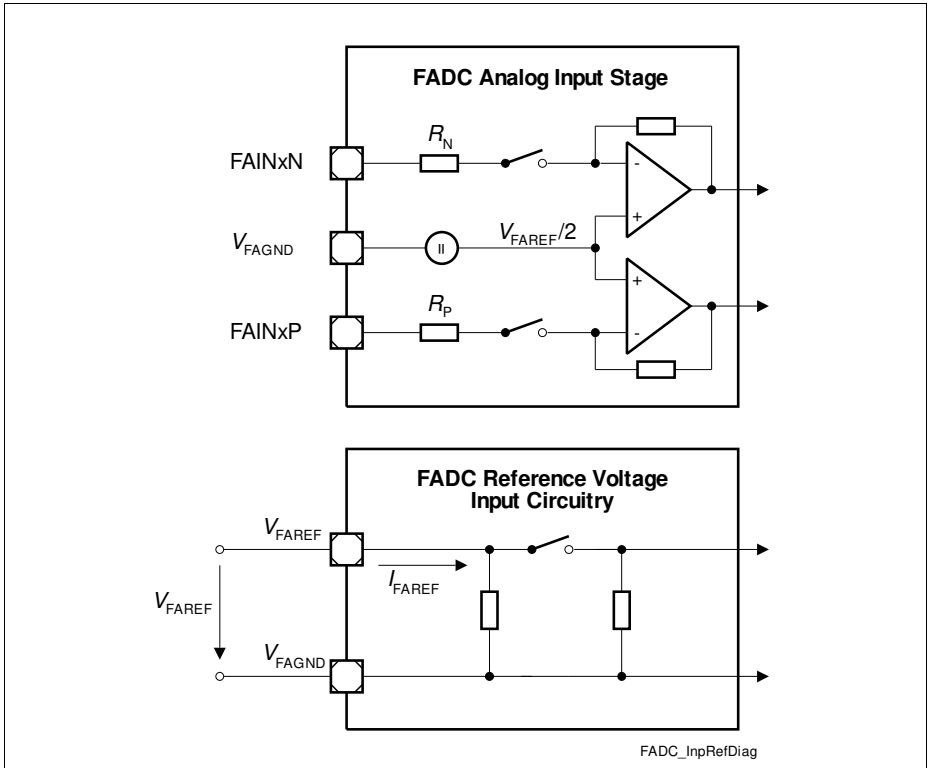

Figure 7 FADC Input Circuits

5.2.4 Oscillator Pins

Table 28 OSC_XTAL Parameters

Parameter	Symbol	Values			Unit	Note / Test Condition
		Min.	Typ.	Max.		
Input current at XTAL1	I_{IX1} CC	-25	–	25	μA	$V_{IN} < V_{DDOSC3}$; $V_{IN} > 0 \text{ V}$
Input frequency	f_{OSC} SR	4	–	40	MHz	Direct Input Mode selected
		8	–	25	MHz	External Crystal Mode selected
Oscillator start-up time ¹⁾	t_{OSCS} CC	–	–	10	ms	
Input high voltage at XTAL1 ²⁾	V_{IHx} SR	$0.7 \times V_{DDOS C3}$	–	$V_{DDOS C3} + 0.5$	V	
Input low voltage at XTAL1	V_{ILx} SR	-0.5	–	$0.3 \times V_{DDOS C3}$	V	
Input Hysteresis for XTAL1 pad ³⁾	$HYSAX$ CC	–	–	200	mV	

1) t_{OSCS} is defined from the moment when $V_{DDOSC3} = 3.13\text{V}$ until the oscillations reach an amplitude at XTAL1 of $0.3 \times V_{DDOSC3}$. The external oscillator circuitry must be optimized by the customer and checked for negative resistance as recommended and specified by crystal suppliers.

2) If the XTAL1 pin is driven by a crystal, reaching a minimum amplitude (peak-to-peak) of $0.4 \times V_{DDOSC3}$ is necessary.

3) Hysteresis is implemented to avoid metastable states and switching due to internal ground bounce. It can't be guaranteed that it suppresses switching due to external system noise.

Note: It is strongly recommended to measure the oscillation allowance (negative resistance) in the final target system (layout) to determine the optimal parameters for the oscillator operation. Please refer to the limits specified by the crystal or ceramic resonator supplier.

5.2.5 Temperature Sensor

Table 29 DTS Parameters

Parameter	Symbol	Values			Unit	Note / Test Condition
		Min.	Typ.	Max.		
Measurement time	t_M CC	–	–	100	μs	
Temperature sensor range	T_{SR} SR	-40	–	150	°C	
Sensor Accuracy (calibrated)	T_{TSA} CC	-6	–	6	°C	
Start-up time after resets inactive	t_{TSST} SR	–	–	20	μs	

The following formula calculates the temperature measured by the DTS in [°C] from the RESULT bit field of the DTSSTAT register.

(1)

$$T_j = \frac{DTSSTAT_{RESULT} - 596}{2,03}$$

5.2.6 Power Supply Current

The total power supply current defined below consists of leakage and switching component.

Application relevant values are typically lower than those given in the following two tables and depend on the customer's system operating conditions (e.g. thermal connection or used application configurations).

The operating conditions for the parameters in the following table are:

$V_{DD} / V_{DDOSC} / V_{DDAF} / V_{DDPF} = 1.365 \text{ V}$, $V_{DDP} / V_{DDOSC} / V_{DDMF} / V_{DDFL3} / V_{DDPF} = 3.47 \text{ V}$,
 $V_{DDM} = 5.25 \text{ V}$ $f_{SRI} / CPU = 270 / 200 \text{ MHz}$, $f_{PCP} = 180 / 200 \text{ MHz}$, $f_{SRI} = 90 / 100 \text{ MHz}$,
 $T_J = 150 \text{ }^\circ\text{C}$

The realistic power pattern defines the following conditions:

- $T_J = 150 \text{ }^\circ\text{C}$
- $f_{SRI} = f_{CPU} = 270 / 200 \text{ MHz}$
- $f_{PCP} = 180 / 200 \text{ MHz}$
- $f_{FPI} = 90 / 100 \text{ MHz}$
- $V_{DD} = V_{DDOSC} = V_{DDAF} = V_{DDPF} = 1.326 \text{ V}$
- $V_{DDP} = V_{DDOSC3} = V_{DDFL3} \quad V_{DDPF3} = V_{DDMF} = 3.366 \text{ V}$
- $V_{DDM} = 5.1 \text{ V}$

The max power pattern defines the following conditions:

- $T_J = 150 \text{ }^\circ\text{C}$
- $f_{SRI} = f_{CPU} = 270 / 200 \text{ MHz}$
- $f_{PCP} = 180 / 200 \text{ MHz}$
- $f_{FPI} = 90 / 100 \text{ MHz}$
- $V_{DD} = V_{DDOSC} = V_{DDAF} = V_{DDPF} = 1.43 \text{ V}$
- $V_{DDP} = V_{DDOSC3} = V_{DDFL3} \quad V_{DDPF3} = V_{DDMF} = 3.63 \text{ V}$
- $V_{DDM} = 5.5 \text{ V}$

Electrical Parameters DC Parameters

Table 30 Power Supply Parameters

Parameter	Symbol	Values			Unit	Note / Test Condition
		Min.	Typ.	Max.		
Core active mode supply current ¹⁾²⁾	$I_{DD\ CC}$	–	–	840 ³⁾	mA	power pattern= max; $f_{CPU}=270\text{ MHz}$
		–	–	621	mA	power pattern= realistic; $f_{CPU}=270\text{ MHz}$
		–	–	735 ⁴⁾	mA	power pattern= max; $f_{CPU}=200\text{ MHz}$
		–	–	555	mA	power pattern= realistic; $f_{CPU}=200\text{ MHz}$
I_{DD} current at PORST Low	$I_{DD_PORS\ T\ CC}$	–	–	298	mA	$T_J=150\text{ °C}$
		–	–	249	mA	$T_J=140\text{ °C}$
E-Ray PLL core supply current	$I_{DDPF\ CC}$	–	–	4	mA	
Oscillator core supply current	$I_{DDOSC\ CC}$	–	–	3	mA	
Analog core supply current	$I_{DDAF\ CC}$	–	–	26	mA	
Sum of all 1.3 V supply currents	$I_{DDSUM\ CC}$	–	–	654	mA	power pattern= realistic; $f_{CPU}=270\text{ MHz}$
		–	–	588	mA	power pattern= realistic; $f_{CPU}=200\text{ MHz}$
E-Ray PLL 3.3V supply	$I_{DDPF3\ CC}$	–	–	4	mA	
Oscillator power supply current, 3.3V	$I_{DDOSC3\ CC}$	–	–	11	mA	

Electrical Parameters DC Parameters

Table 30 Power Supply Parameters (cont'd)

Parameter	Symbol	Values			Unit	Note / Test Condition
		Min.	Typ.	Max.		
FADC analog supply current, 3.3V	I_{DDMF} CC	–	–	15	mA	
I_{DDP} current at PORST Low	I_{DDP_PORST} CC	–	–	7	mA	
I_{DDP} current no pad activity, LVDS off ⁵⁾	I_{DDP} CC	–	–	$I_{DDP_PORST} + 25$	mA	including flash read current
		–	–	$I_{DDP_PORST} + 55$	mA	including flash programming current ⁶⁾
		–	–	$I_{DDP_PORST} + 40$ ⁷⁾	mA	including flash erase verify current ⁶⁾
Flash memory current ⁵⁾	I_{DDFL3} CC	–	–	98	mA	flash read current
		–	–	29	mA	flash programming current ⁶⁾
		–	–	98	mA	flash erase current ⁶⁾
Current Consumption of LVDS Pad Pairs	I_{LVDS} CC	–	–	24	mA	in total for all LVDS pairs
Sum of all 3.3 V supply currents, no pad activity, LVDS off	I_{DD3SUM} CC	–	–	160 ⁸⁾	mA	including flash read current
ADC 5V power supply current	I_{DDM} CC	–	–	6	mA	

Electrical Parameters DC Parameters

Table 30 Power Supply Parameters (cont'd)

Parameter	Symbol	Values			Unit	Note / Test Condition
		Min.	Typ.	Max.		
Maximum power dissipation	PD CC	–	–	1633	mW	power pattern= max; $f_{CPU}=270$ MHz
		–	–	1488	mW	power pattern= realisti c; $f_{CPU}=270$ MHz
		–	–	1523	mW	power pattern= max; $f_{CPU}=200$ MHz
		–	–	1403	mW	power pattern= realisti c; $f_{CPU}=200$ MHz

- 1) Infineon Power Loop: CPU and PCP running, all peripherals active. The power consumption of each customer application will most probably be lower than this value, but must be evaluated separately.
- 2) This current includes the E-Ray module power consumption, including the PCP operation component.
- 3) The I_{DD} decreases typically by 97 mA if the f_{CPU} decreases by 50MHz, at constant T_J
- 4) The I_{DD} decreases typically by 105 mA if the f_{CPU} decreases by 50MHz, at constant T_J
- 5) D-Flash read, write, or erase operation in parallel to P-Flash operations name in Test Condition is covered already in the give current limits.
- 6) Relevant for the power supply dimensioning, not for thermal considerations.
- 7) In case of erase of Program Flash PFx, internal flash array loading effects may generate transient current spikes of up to 15 mA for maximum 5 ms per flash module.
- 8) For power supply dimensioning of V_{DDP} 30 mA have to added for flash programming case.

Note: In general current consumption for operations with data flash are always lower than the defined values for program flash read operation.

5.2.6.1 Calculating the 1.3 V Current Consumption

The current consumption of the 1.3 V rail compose out of two parts:

- Static current consumption
- Dynamic current consumption

The static current consumption is related to the device temperature T_J and the dynamic current consumption depends of the configured clocking frequencies and the software

Electrical Parameters DC Parameters

application executed. These two parts needs to be added in order to get the rail current consumption.

(2)

$$I_0 = 3,75 \left[\frac{\text{mA}}{\text{C}} \right] \times e^{0,02041 \times T_J[\text{C}]}$$

(3)

$$I_0 = 18,77 \left[\frac{\text{mA}}{\text{C}} \right] \times e^{0,01825 \times T_J[\text{C}]}$$

Function 2 defines the typical static current consumption and Function 3 defines the maximum static current consumption. Both functions are valid for $V_{DD} = 1.326 \text{ V}$.

For the dynamic current consumption using the real pattern and $f_{SRI} = 3 / 2 * f_{PCP} = 3 * f_{FPI}$ the function 4 applies:

(4)

$$I_{Dym} = 1,22 \left[\frac{\text{mA}}{\text{MHz}} \right] \times f_{CPU}[\text{MHz}]$$

For the dynamic current consumption using the real pattern and $f_{SRI} = f_{PCP} = 2 * f_{FPI}$ the function 5 applies:

(5)

$$I_{Dym} = 1,305 \left[\frac{\text{mA}}{\text{MHz}} \right] \times f_{CPU}[\text{MHz}]$$

and this finally results in

(6)

$$I_{DD} = I_0 + I_{DYM}$$

5.3 AC Parameters

All AC parameters are defined with maximum driver strength unless otherwise noted.

5.3.1 Testing Waveforms

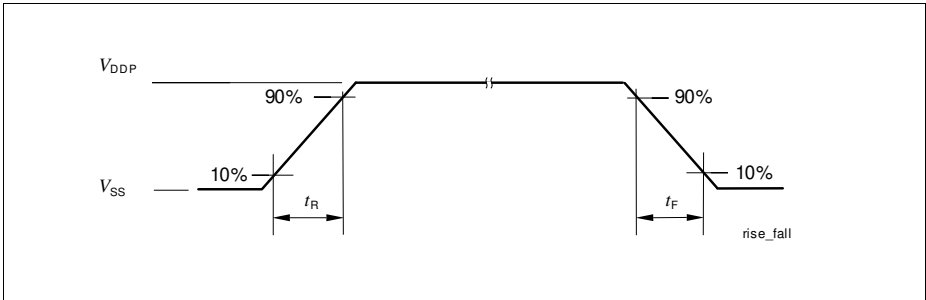

Figure 8 Rise/Fall Time Parameters

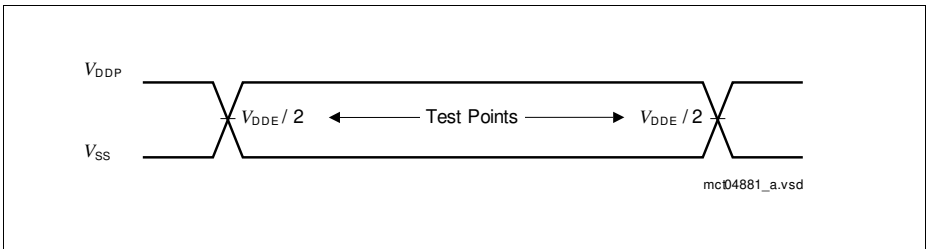

Figure 9 Testing Waveform, Output Delay

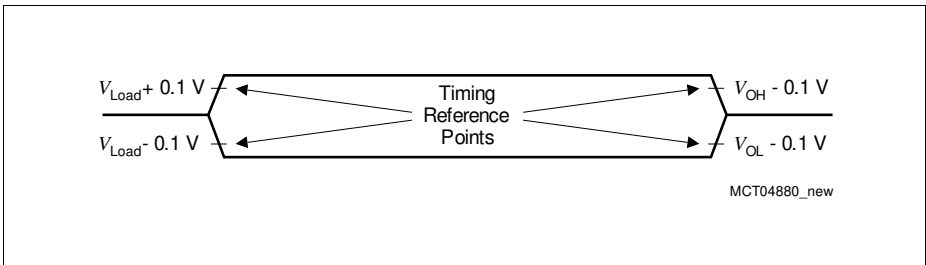

Figure 10 Testing Waveform, Output High Impedance

5.3.2 Power Sequencing

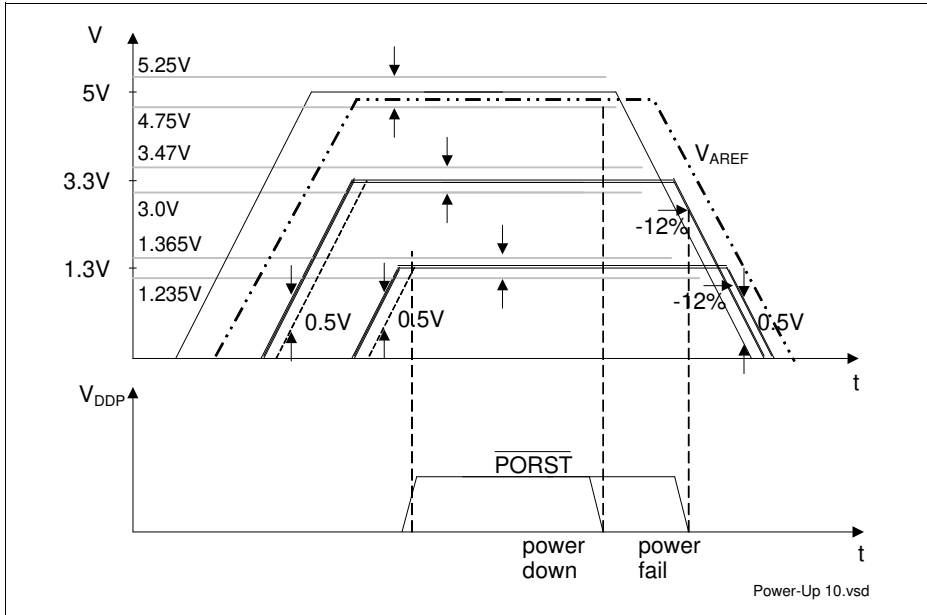

Figure 11 5 V / 3.3 V / 1.3 V Power-Up/Down Sequence

The following list of rules applies to the power-up/down sequence:

- All ground pins V_{SS} must be externally connected to one single star point in the system. Regarding the DC current component, all ground pins are internally directly connected.
- At any moment in time to avoid increased latch-up risk, each power supply must be higher than any lower_power_supply - 0.5 V, or: $V_{DD5} > V_{DD3.3} - 0.5\text{ V}$; $V_{DD5} > V_{DD1.3} - 0.5\text{ V}$; $V_{DD3.3} > V_{DD1.3} - 0.5\text{ V}$, see [Figure 11](#).
 - The latch-up risk is minimized if the I/O currents are limited to:
 - 20 mA for one pin group
 - AND 100 mA for the completed device I/Os
 - AND additionally before power-up / after power-down:
 - 1 mA for one pin in inactive mode (0 V on all power supplies)
- During power-up and power-down, the voltage difference between the power supply pins of the same voltage (3.3 V, 1.3 V, and 5 V) with different names (for example V_{DDP} , V_{DDFL3} ...), that are internally connected via diodes, must be lower than 100 mV. On the other hand, all power supply pins with the same name (for example all V_{DDP}),

Electrical Parameters AC Parameters

are internally directly connected. It is recommended that the power pins of the same voltage are driven by a single power supply.

1. The $\overline{\text{PORST}}$ signal may be deactivated after all $V_{\text{DD}5}$, $V_{\text{DD}3.3}$, $V_{\text{DD}1.3}$, and V_{AREF} power-supplies and the oscillator have reached stable operation, within the normal operating conditions.
2. At normal power down the $\overline{\text{PORST}}$ signal should be activated within the normal operating range, and then the power supplies may be switched off. Care must be taken that all Flash write or delete sequences have been completed.
3. At power fail the $\overline{\text{PORST}}$ signal must be activated at latest when any 3.3 V or 1.3 V power supply voltage falls 12% below the nominal level. If, under these conditions, the $\overline{\text{PORST}}$ is activated during a Flash write, only the memory row that was the target of the write at the moment of the power loss will contain unreliable content. In order to ensure clean power-down behavior, the $\overline{\text{PORST}}$ signal should be activated as close as possible to the normal operating voltage range.
4. In case of a power-loss at any power-supply, all power supplies must be powered-down, conforming at the same time to the rules number 2 and 4.
5. Although not necessary, it is additionally recommended that all power supplies are powered-up/down together in a controlled way, as tight to each other as possible.
6. Additionally, regarding the ADC reference voltage V_{AREF} :
 - V_{AREF} must power-up at the same time or later then V_{DDM} , and
 - V_{AREF} must power-down either earlier or at latest to satisfy the condition $V_{\text{AREF}} < V_{\text{DDM}} + 0.5 \text{ V}$. This is required in order to prevent discharge of V_{AREF} filter capacitance through the ESD diodes through the V_{DDM} power supply. In case of discharging the reference capacitance through the ESD diodes, the current must be lower than 5 mA.

5.3.3 Power, Pad and Reset Timing

Table 31 Reset Timings Parameters

Parameter	Symbol	Values			Unit	Note / Test Condition
		Min.	Typ.	Max.		
Application Reset Boot Time ¹⁾²⁾	t_B CC	–	–	960	μs	$f_{\text{CPU}} = 270 \text{ MHz}$
		–	–	1140	μs	$f_{\text{CPU}} = 200 \text{ MHz}$
Power on Reset Boot Time ³⁾⁴⁾	t_{BP} CC	–	–	2.5	ms	
HWCFG pins hold time from ESR0 rising edge	t_{HDH} SR	16 / f_{FPI}	–	–	ns	
HWCFG pins setup time to ESR0 rising edge	t_{HDS} SR	0	–	–	ns	
Ports inactive after ESR0 reset active	t_{PI} CC	–	–	$8/f_{\text{FPI}}$	ns	
Ports inactive after PORST reset active ⁵⁾	t_{PIP} CC	–	–	150	ns	
Minimum PORST active time after power supplies are stable at operating levels	t_{POA} SR	10	–	–	ms	
$\overline{\text{TESTMODE}} / \overline{\text{TRST}}$ hold time from PORST rising edge	t_{POH} SR	100	–	–	ns	
PORST rise time	t_{POR} SR	–	–	50	ms	
$\overline{\text{TESTMODE}} / \overline{\text{TRST}}$ setup time to PORST rising edge	t_{POS} SR	0	–	–	ns	
Application Reset inactive after PORST deassertion	t_{POR_APP} SR	–	–	40 ⁶⁾	μs	

1) The duration of the boot time is defined between the rising edge of the internal application reset and the clock cycle when the first user instruction has entered the CPU pipeline and its processing starts.

2) The given time includes the time of the internal reset extension for a configured value of SCU_RSTCNTCON.RELSA = 0x05BE.

3) The duration of the boot time is defined between the rising edge of the $\overline{\text{PORST}}$ and the clock cycle when the first user instruction has entered the CPU pipeline and its processing starts.

4) The given time includes the internal reset extension time for the System and Application Reset which is visible through ESR0.

5.3.4 Phase Locked Loop (PLL)

Table 32 PLL_SysClk Parameters

Parameter	Symbol	Values			Unit	Note / Test Condition
		Min.	Typ.	Max.		
Accumulated Jitter	D_P CC	-7	–	7	ns	
Modulation frequency	f_{MOD} SR	50	–	200	kHz	
PLL base frequency	$f_{PLLBASE}$ CC	50	200	320	MHz	
VCO input frequency	f_{REF} CC	8	–	16	MHz	
VCO frequency range	f_{VCO} CC	400	–	720	MHz	with inactive modulation
		400	–	600	MHz	with active modulation
Modulation jitter	J_{MOD} CC	–	–	2.5	ns	
Total long term jitter	J_{TOT} CC	–	–	9.5	ns	Sum of D_P and J_{MOD}
Modulation Amplitude	MA SR	0	–	2.5	%	% of f_{VCO}
PLL lock-in time	t_L CC	14	–	200	μ s	$N > 32$
		14	–	400	μ s	$N \leq 32$
System frequency deviation	f_{SYSD} CC	–	–	0.01	%	with active modulation

Phase Locked Loop Operation

When PLL operation is enabled and configured, the PLL clock f_{VCO} (and with it the SRI-Bus clock f_{SRI}) is constantly adjusted to the selected frequency. The PLL is constantly adjusting its output frequency to correspond to the input frequency (from crystal or clock source), resulting in an accumulated jitter that is limited. This means that the relative deviation for periods of more than one clock cycle is lower than for a single clock cycle.

This is especially important for bus cycles using wait states and for the operation of timers, serial interfaces, etc. For all slower operations and longer periods (e.g. pulse train generation or measurement, lower baudrates, etc.) the deviation caused by the PLL jitter is negligible.

Electrical Parameters AC Parameters

Two formulas are defined for the (absolute) approximate maximum value of jitter D_m in [ns] dependent on the K2 - factor, the SRI clock frequency f_{SRI} in [MHz], and the number m of consecutive f_{SRI} clock periods.

for $(K2 \leq 100)$ and $(m \leq (f_{SRI}[\text{MHz}])/2)$

$$|D_m[\text{ns}]| = \left(\frac{740}{K2 \times f_{SRI}[\text{MHz}]} + 5 \right) \times \left(\frac{(1 - 0,01 \times K2) \times (m - 1)}{0,5 \times f_{SRI}[\text{MHz}] - 1} + 0,01 \times K2 \right) \quad (7)$$

$$\text{else} \quad |D_m[\text{ns}]| = \frac{740}{K2 \times f_{SRI}[\text{MHz}]} + 5 \quad (8)$$

With rising number m of clock cycles the maximum jitter increases linearly up to a value of m that is defined by the K2-factor of the PLL. Beyond this value of m the maximum accumulated jitter remains at a constant value. Further, a lower SRI-Bus clock frequency f_{SRI} results in a higher absolute maximum jitter value.

Note: The specified PLL jitter values are valid if the capacitive load per pin does not exceed $C_L = 20$ pF with the maximum driver and sharp edge.

Note: The maximum peak-to-peak noise on the pad supply voltage, measured between V_{DDOSC3} and V_{SSOSC} , is limited to a peak-to-peak voltage of $V_{pp} = 100$ mV for noise frequencies below 300 KHz and $V_{pp} = 40$ mV for noise frequencies above 300 KHz.

The maximum peak-to-peak noise on the pad supply voltage, measured between V_{DDOSC} and V_{SSOSC} , is limited to a peak-to-peak voltage of $V_{pp} = 100$ mV for noise frequencies below 300 KHz and $V_{pp} = 40$ mV for noise frequencies above 300 KHz.

These conditions can be achieved by appropriate blocking of the supply voltage as near as possible to the supply pins and using PCB supply and ground planes.

Oscillator Watchdog (OSC_WDT)

The expected input frequency is selected via the bit field SCU_OSCCON.OSCVAL. The OSC_WDT checks for too low frequencies and for too high frequencies.

The frequency that is monitored is f_{OSCREF} which is derived for f_{OSC} .

(9)

$$f_{OSCREF} = \frac{f_{OSC}}{OSCVAL + 1}$$

The divider value SCU_OSCCON.OSCVAL has to be selected in a way that f_{OSCREF} is 2.5 MHz.

Electrical Parameters AC Parameters

Note: f_{OSCREF} has to be within the range of 2 MHz to 3 MHz and should be as close as possible to 2.5 MHz.

The monitored frequency is too low if it is below 1.25 MHz and too high if it is above 7.5 MHz. This leads to the following two conditions:

- Too low: $f_{OSC} < 1.25 \text{ MHz} \times (\text{SCU_OSCCON.OSCVAL}+1)$
- Too high: $f_{OSC} > 7.5 \text{ MHz} \times (\text{SCU_OSCCON.OSCVAL}+1)$

Note: The accuracy is 30% for these boundaries.

Frequency Modulation

Frequency modulation defines a slow and predictable variation of the clock speed. The modulation configuration itself is controlled via register SCU_PLLCON2 where the two bit fields define the modulation properties.

$$f_{\text{MOD}} = \frac{f_{\text{OSC}}}{P} \times \frac{\text{MODFREQ} \times 31, 32}{\text{MODAMP}} \quad (10)$$

$$\text{MA} = \frac{\text{MODAMP}}{N \times 161} \quad (11)$$

5.3.5 ERAY Phase Locked Loop (ERAY_PLL)

Table 33 PLL_ERAY Parameters

Parameter	Symbol	Values			Unit	Note / Test Condition
		Min.	Typ.	Max.		
Accumulated jitter at SYSCLK pin	$D_{PP} CC$	-0.8	–	0.8	ns	
Accumulated_Jitter	$D_p CC$	-0.5	–	0.5	ns	
PLL Base Frequency of the ERAY PLL	$f_{PLLBASE_ERAY} CC$	50	250	360	MHz	
VCO input frequency of the ERAY PLL	$f_{REF} CC$	20	–	40	MHz	
VCO frequency range of the ERAY PLL	$f_{VCO_ERA} CC$	450	–	500	MHz	
PLL lock-in time	$t_L CC$	5.6	–	200	μs	

Note: The specified PLL jitter values are valid if the capacitive load per pin does not exceed $C_L = 20$ pF with the maximum driver and sharp edge.

Note: The maximum peak-to-peak noise on the pad supply voltage, measured between V_{DDPF3} and V_{SSPF} , is limited to a peak-to-peak voltage of $V_{PP} = 100$ mV for noise frequencies below 300 KHz and $V_{PP} = 40$ mV for noise frequencies above 300 KHz.

These conditions can be achieved by appropriate blocking of the supply voltage as near as possible to the supply pins and using PCB supply and ground planes.

5.3.6 JTAG Interface Timing

The following parameters are applicable for communication through the JTAG debug interface. The JTAG module is fully compliant with IEEE1149.1-2000.

Note: These parameters are not subject to production test but verified by design and/or characterization.

**Table 34 JTAG Interface Timing Parameters
(Operating Conditions apply)**

Parameter	Symbol	Values			Unit	Note / Test Condition
		Min.	Typ.	Max.		
TCK clock period	t_1 SR	25	–	–	ns	–
TCK high time	t_2 SR	10	–	–	ns	–
TCK low time	t_3 SR	10	–	–	ns	–
TCK clock rise time	t_4 SR	–	–	4	ns	–
TCK clock fall time	t_5 SR	–	–	4	ns	–
TDI/TMS setup to TCK rising edge	t_6 SR	6	–	–	ns	–
TDI/TMS hold after TCK rising edge	t_7 SR	6	–	–	ns	–
TDO valid after TCK falling edge ¹⁾ (propagation delay)	t_8 CC	–	–	13	ns	$C_L = 50$ pF
	t_8 CC	3	–	–	ns	$C_L = 20$ pF
TDO hold after TCK falling edge ¹⁾	t_{18} CC	2	–	–	ns	
TDO high imped. to valid from TCK falling edge ¹⁾²⁾	t_9 CC	–	–	14	ns	$C_L = 50$ pF
TDO valid to high imped. from TCK falling edge ¹⁾	t_{10} CC	–	–	13.5	ns	$C_L = 50$ pF

1) The falling edge on TCK is used to generate the TDO timing.

2) The setup time for TDO is given implicitly by the TCK cycle time.

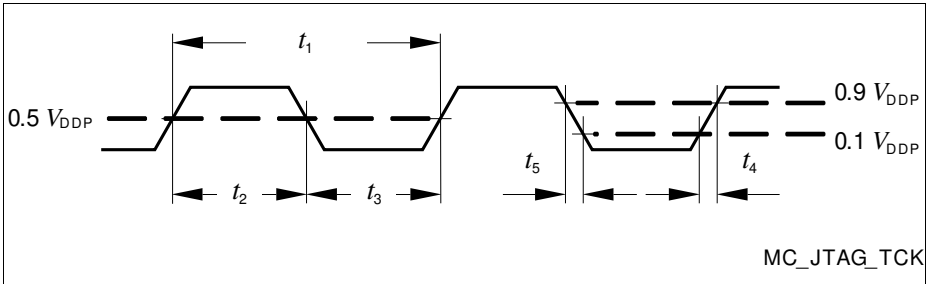

Figure 13 Test Clock Timing (TCK)

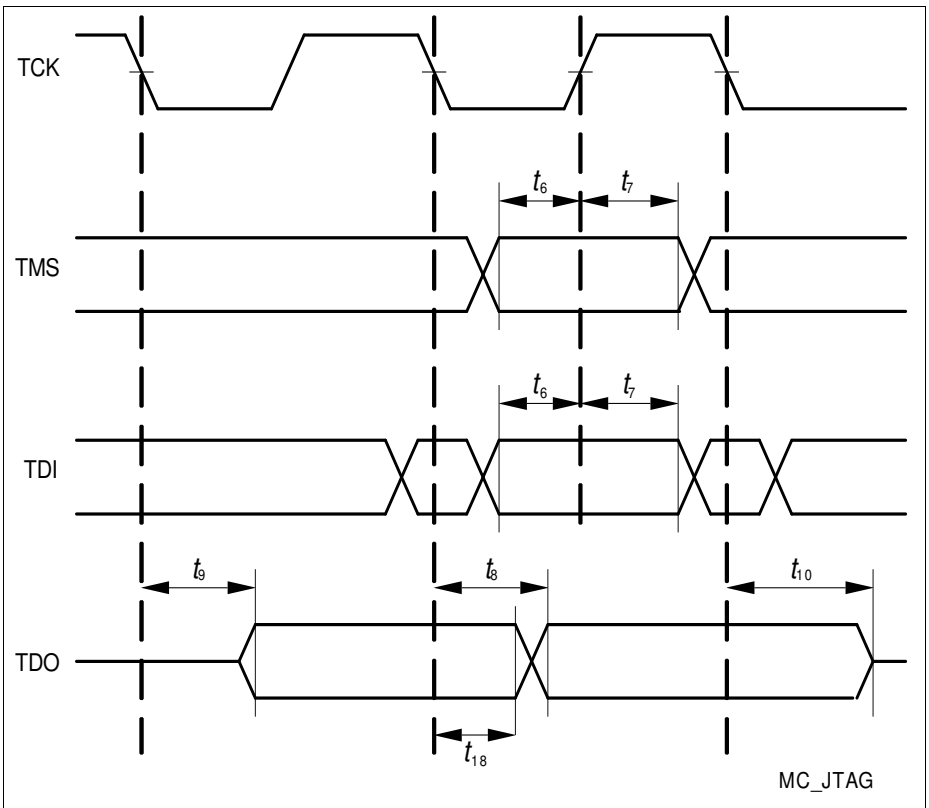

Figure 14 JTAG Timing

5.3.7 DAP Interface Timing

The following parameters are applicable for communication through the DAP debug interface.

Note: These parameters are not subject to production test but verified by design and/or characterization.

Table 35 DAP Parameters

Parameter	Symbol	Values			Unit	Note / Test Condition
		Min.	Typ.	Max.		
DAP0 clock period ¹⁾	t_{TCK} SR	12.5	–	–	ns	
DAP0 high time	t_{12} SR	4	–	–	ns	
DAP0 low time ¹⁾	t_{13} SR	4	–	–	ns	
DAP0 clock rise time	t_{14} SR	–	–	2	ns	
DAP0 clock fall time	t_{15} SR	–	–	2	ns	
DAP1 setup to DAP0 rising edge	t_{16} SR	6.0	–	–	ns	
DAP1 hold after DAP0 rising edge	t_{17} SR	6.0	–	–	ns	
DAP1 valid per DAP0 clock period ²⁾	t_{19} CC	8	–	–	ns	$C_L = 20$ pF; $f = 80$ MHz
		10	–	–	ns	$C_L = 50$ pF; $f = 40$ MHz

1) See the DAP chapter for clock rate restrictions in the Active:IDLE protocol state.

2) The Host has to find a suitable sampling point by analyzing the sync telegram response.

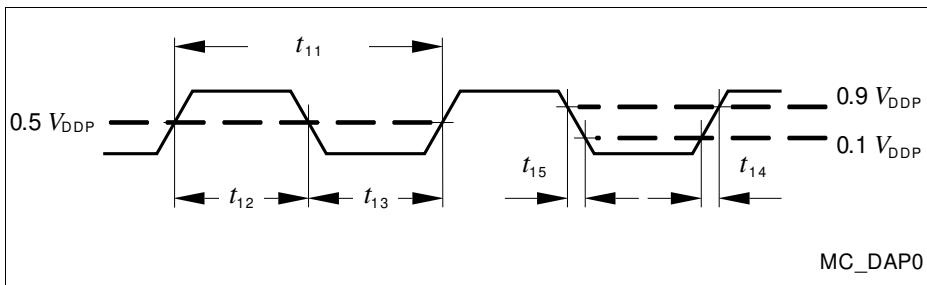

Figure 15 Test Clock Timing (DAP0)

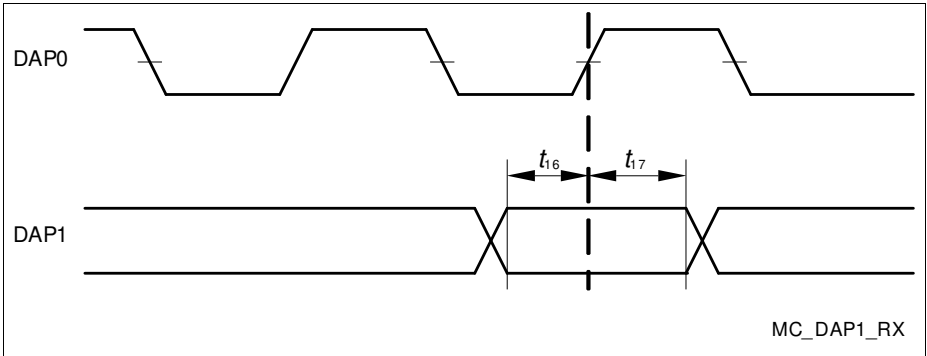

Figure 16 DAP Timing Host to Device

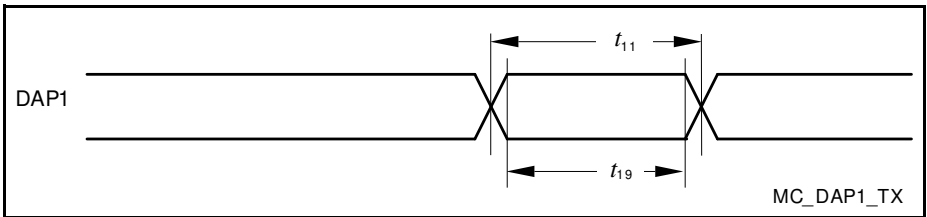

Figure 17 DAP Timing Device to Host

5.3.8 Micro Link Interface (MLI) Timing

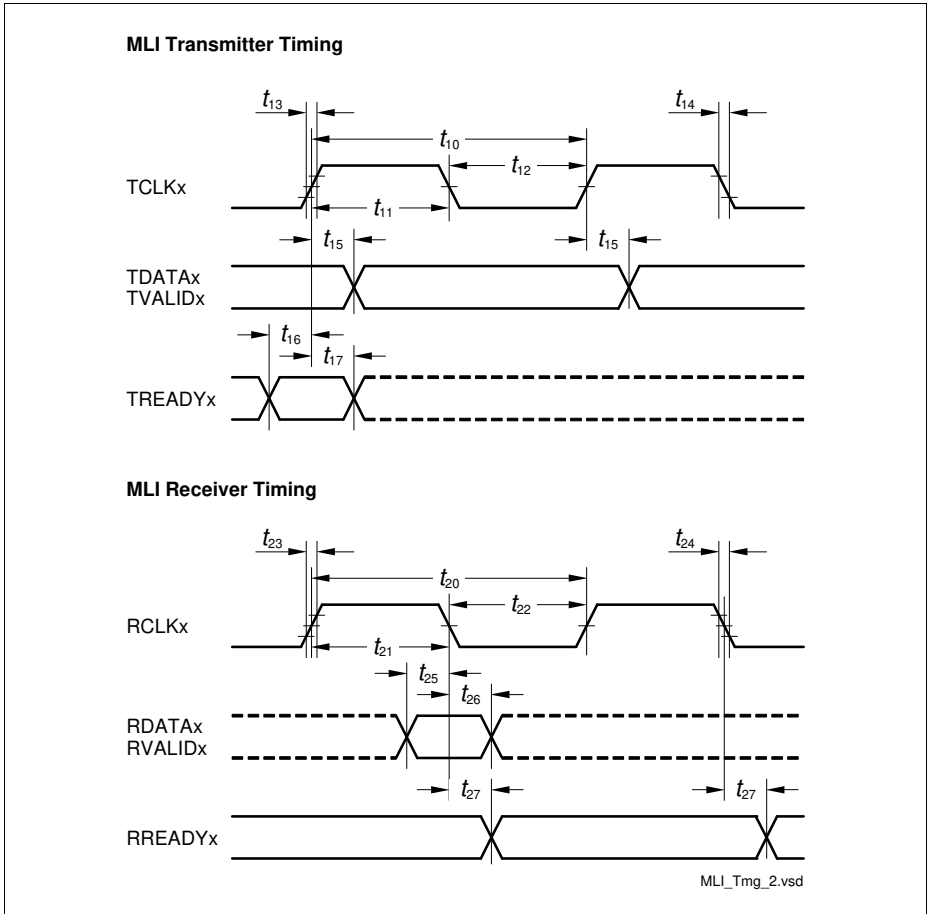

Figure 18 MLI Interface Timing

Note: The generation of $RREADYx$ is in the input clock domain of the receiver. The reception of $TREADYx$ is asynchronous to $TCLKx$.

The MLI parameters are valid for $C_L = 50$ pF and strong driver medium edge.

Electrical Parameters AC Parameters

Table 36 MLI Receiver

Parameter	Symbol	Values			Unit	Note / Test Condition
		Min.	Typ.	Max.		
RCLK clock period	t_{20} SR	$1 / f_{FPI}$	–	–	ns	
RCLK high time ¹⁾²⁾	t_{21} SR	–	$0.5 \times t_{20}$	–	ns	
RCLK low time ¹⁾²⁾	t_{22} SR	–	$0.5 \times t_{20}$	–	ns	
RCLK rise time ³⁾	t_{23} SR	–	–	4	ns	
RCLK fall time ³⁾	t_{24} SR	–	–	4	ns	
RDATA/RVALID setup time before RCLK falling edge	t_{25} SR	4.2	–	–	ns	
RDATA/RVALID hold time after RCLK falling edge	t_{26} SR	2.2	–	–	ns	
RREADY output delay time	t_{27} SR	0	–	16	ns	

1) The following formula is valid: $t_{21} + t_{22} = t_{20}$.

2) Min and Max values for this parameter can be derived from the typ. value by considering the other receiver timing parameters.

3) The RCLK max. input rise/fall times are best case parameters for $f_{SYS} = 90$ MHz. For reduction of EMI, slower input signal rise/fall times can be used for longer RCLK clock periods.

Table 37 MLI Transmitter

Parameter	Symbol	Values			Unit	Note / Test Condition
		Min.	Typ.	Max.		
TCLK clock period	t_{10} CC	$2 \times 1 / f_{FPI}$	–	–	ns	
TCLK high time ¹⁾²⁾	t_{11} CC	$0.45 \times t_{10}$	$0.5 \times t_{10}$	$0.55 \times t_{10}$	ns	
TCLK low time ¹⁾²⁾	t_{12} CC	$0.45 \times t_{10}$	$0.5 \times t_{10}$	$0.55 \times t_{10}$	ns	
TCLK rise time	t_{13} CC	–	–	$0.3 \times t_{10}$ ³⁾	ns	
TCLK fall time	t_{14} CC	–	–	$0.3 \times t_{10}$ ³⁾	ns	

Electrical Parameters AC Parameters

Table 37 MLI Transmitter (cont'd)

Parameter	Symbol	Values			Unit	Note / Test Condition
		Min.	Typ.	Max.		
TDATA/TVALID output delay time	t_{15} CC	-3	–	4.4	ns	
TREADY setup time before TCLK rising edge	t_{16} SR	18	–	–	ns	
TREADY hold time after TCLK rising edge	t_{17} SR	-2	–	–	ns	

1) The following formula is valid: $t_{11} + t_{12} = t_{10}$.

2) The min./max. TCLK low/high times t_{11}/t_{12} include the PLL jitter of fSYS. Fractional divider settings must be regarded additionally to t_{11} / t_{12} .

3) For high-speed MLI interface, strong driver sharp or medium edge selection (class A2 pad) is recommended for TCLK.

5.3.9 Micro Second Channel (MSC) Interface Timing

The MSC parameters are valid for $C_L = 50$ pF.

Table 38 MSC Parameters

Parameter	Symbol	Values			Unit	Note / Test Condition
		Min.	Typ.	Max.		
FCLP clock period ¹⁾²⁾	t_{40} CC	$2 \times T_{MSC}$ ³⁾	–	–	ns	
SOP ⁴⁾ /ENx outputs delay from FCLP ⁴⁾ rising edge	t_{45} CC	-2	–	5	ns	ENx with strong driver and sharp (minus) edge
		-2	–	10	ns	ENx with strong driver and medium (minus) edge
		0	–	21	ns	ENx with strong driver and soft edge
SDI bit time	t_{46} CC	$8 \times T_{MSC}$	–	–	ns	

Electrical Parameters AC Parameters

Table 38 MSC Parameters (cont'd)

Parameter	Symbol	Values			Unit	Note / Test Condition
		Min.	Typ.	Max.		
SDI rise time	t_{48} SR	–	–	100	ns	
SDI fall time	t_{49} SR	–	–	100	ns	

- 1) FCLP signal rise/fall times are only defined by the pad rise/fall times.
- 2) FCLP signal high and low can be minimum $1 \times T_{MSC}$
- 3) $T_{MSC} = T_{SYS} = 1 / f_{SYS}$.
- 4) SOP / FCLP either propagated by LVDS or by CMOS strong driver and non soft edge.

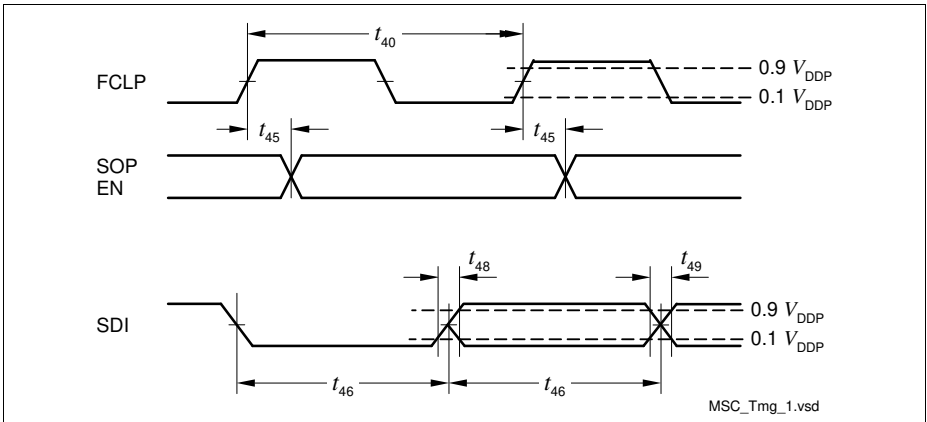

Figure 19 MSC Interface Timing

Note: The data at SOP should be sampled with the falling edge of FCLP in the target device.

5.3.10 SSC Master/Slave Mode Timing

The SSC parameters are valid for $C_L = 50$ pF and strong driver medium edge.

Table 39 SSC Parameters

Parameter	Symbol	Values			Unit	Note / Test Condition
		Min.	Typ.	Max.		
SCLK clock period ¹⁾²⁾³⁾	t_{50} CC	$2 \times 1 / f_{FPI}$	–	–	ns	
MTSR/SLSOx delay from SCLK rising edge	t_{51} CC	0	–	8	ns	
MRST setup to SCLK latching edge ³⁾	t_{52} SR	16.5	–	–	ns	
MRST hold from SCLK latching edge ³⁾	t_{53} SR	0	–	–	ns	
SCLK input clock period ¹⁾³⁾	t_{54} SR	$4 \times 1 / f_{FPI}$	–	–	ns	
SCLK input clock duty cycle	t_{55} – t_{54} SR	45	–	55	%	
MTSR setup to SCLK latching edge ³⁾⁴⁾	t_{56} SR	$1 / f_{FPI}$	–	–	ns	
MTSR hold from SCLK latching edge	t_{57} SR	$1 / f_{FPI} + 5$	–	–	ns	
SLSI setup to first SCLK latching edge	t_{58} SR	$1 / f_{FPI} + 5$	–	–	ns	
SLSI hold from last SCLK latching edge ⁵⁾	t_{59} SR	7	–	–	ns	
MRST delay from SCLK shift edge	t_{60} CC	0	–	16.5	ns	
SLSI to valid data on MRST	t_{61} CC	–	–	16.5	ns	

1) SCLK signal rise/fall times are the same as the rise/fall times of the pad.

2) SCLK signal high and low times can be minimum $1 \times TSSC$.

3) $TSSC_{min} = T_{SYS} = 1/f_{SYS}$.

4) Fractional divider switched off, SSC internal baud rate generation used.

Electrical Parameters AC Parameters

- 5) For CON.PH=1 slave select must not be removed before the following shifting edge. This mean, that what ever is configured (shifting / latching first), SLSI must not be de-activated before the last trailing edge from the pair of shifting / latching edges.

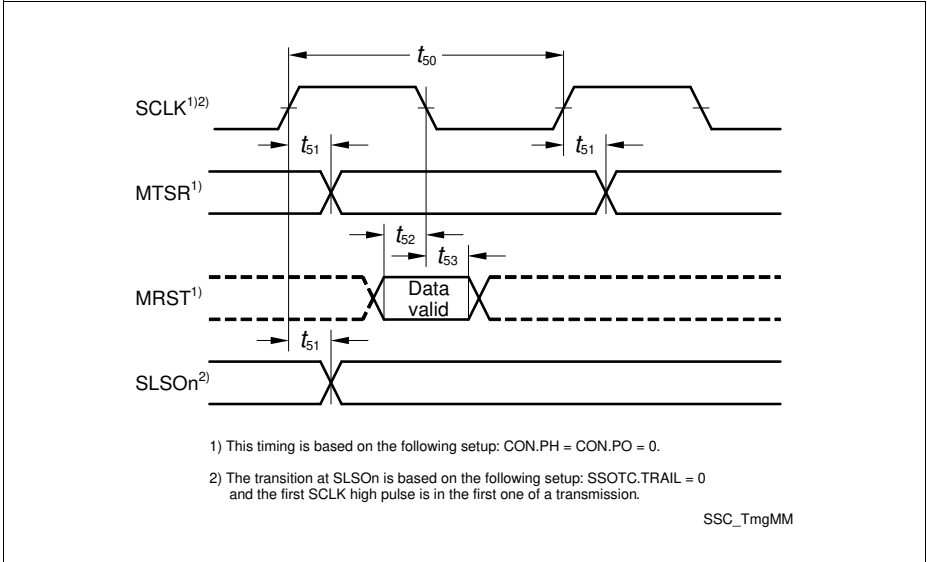

Figure 20 SSC Master Mode Timing

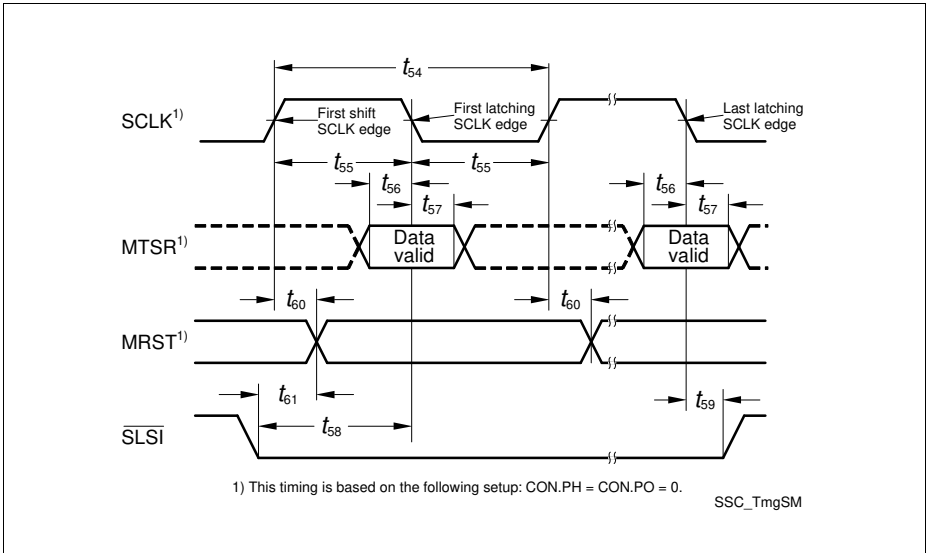

Figure 21 SSC Slave Mode Timing

5.3.11 ERAY Interface Timing

The timings of this section are valid for the strong driver and either sharp edge or medium edge settings of the output drivers with $C_L = 25 \text{ pF}$.

The ERAY interface is only available for the SAK-TC1793F-512F270EF / SAK-TC1793F-512F270EB / SAK-TC1793F-512F200EF / SAK-TC1793F-512F200EB / SAK-TC1793S-512F270EF.

Table 40 ERAY Parameters

Parameter	Symbol	Values			Unit	Note / Test Condition
		Min.	Typ.	Max.		
Time span from last BSS to FES without the influence of quartz tolerancies (d10Bit_TX) ¹⁾	t_{60} CC	997.75	–	1002.25	ns	
TxD data valid from fsample flip flop txd_reg TxDA, TxDB (dTxAsym) ²⁾³⁾	t_{61} - t_{62} CC	–	–	1.5	ns	Asymmetrical delay of rising and falling edge (TxDA, TxDB)
Time span between last BSS and FES without influence of quartz tolerancies (d10Bit_RX) ¹⁾⁴⁾⁵⁾	t_{63} SR	966	–	1046.1	ns	
RxD capture by fsample (RxDA/RxDB sampling flip-flop) (dRxAsym) ⁶⁾	t_{64} - t_{65} CC	–	–	3.0	ns	Asymmetrical delay of rising and falling edge (RxDA, RxDB)
TxD data delay from sampling flip-flop	$dTxdly$ CC	–	–	10.0	ns	$Px_PDR.PDy = 000_B$
		–	–	15.0	ns	$Px_PDR.PDy = 001_B$
RxD capture delay by sampling flip-flop	$dRxdly$ CC	–	–	10.0	ns	

1) This includes the PLL_ERAY accumulated jitter.

2) Refers to delays caused by the asymmetries of the output drivers of the digital logic and the GPIO pad drivers. Quartz tolerance and PLL_ERAY accumulated jitter are not included.

3) E-Ray TxD output drivers have an asymmetry of rising and falling edges of $|t_{FA2} - t_{RA2}| \leq 1 \text{ ns}$.

4) Limits of 966ns and 1046.1ns correspond to (30%, 70%) * V_{DDP} FlexRay standard input thresholds. For input thresholds of this product, a correction of - 0.5 ns and +0.1 ns has to be applied.

Electrical Parameters AC Parameters

- 5) Valid for output slopes of the bus driver of $dRxSlope \leq 5ns$, $20\% * V_{DDP}$ to $80\% * V_{DDP}$, according to the FlexRay Electrical Physical Layer Specification V2.1B. For A2 pads, the rise and fall times of the incoming signal have to satisfy the following inequality: $-1.6ns \leq t_{FA2} - t_{RA2} \leq 1.3ns$.
- 6) Valid for output slopes of the bus driver of $dRxSlope \leq 5ns$, $20\% * V_{DDP}$ to $80\% * V_{DDP}$, according to the FlexRay Electrical Physical Layer Specification V2.1B. For A2 pads, the rise and fall times of the incoming signal have to satisfy the following inequality: $-1.6ns \leq t_{FA2} - t_{RA2} \leq 1.3ns$.

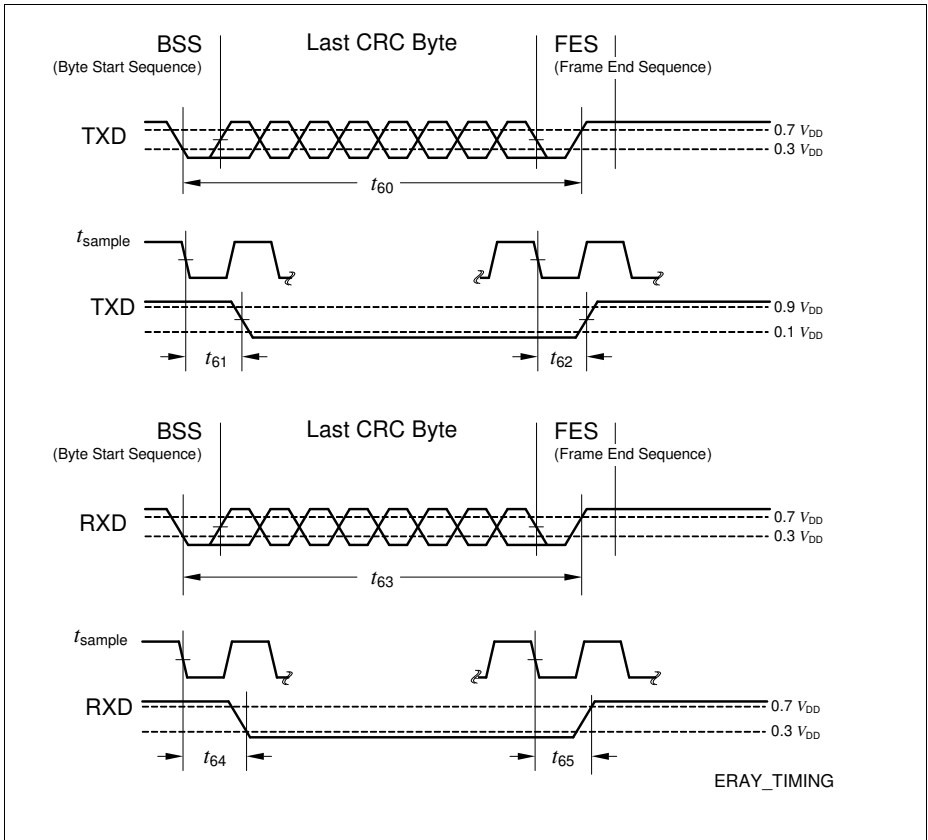

Figure 22 ERAY Timing

5.3.12 EBU Timings

5.3.12.1 BFCLKO Output Clock Timing

$V_{SS} = 0\text{ V}; V_{DD} = 1.3\text{ V} \pm 5\%$; $V_{DDEBU} = 2.5\text{ V} \pm 5\%$ and $3.3\text{ V} \pm 5\%$;
 $C_L = 35\text{ pF}$

Table 41 BFCLKO Output Clock Timing Parameters¹⁾

Parameter	Symbol	Values			Unit	Note / Test Condition
		Min.	Typ.	Max.		
BFCLKO clock period	t_{BFCLKO} CC	13.33 ²⁾	–	–	ns	–
BFCLKO high time	t_5 CC	3	–	–	ns	–
BFCLKO low time	t_6 CC	3	–	–	ns	–
BFCLKO rise time	t_7 CC	–	–	3	ns	–
BFCLKO fall time	t_8 CC	–	–	3	ns	–
BFCLKO duty cycle $t_5/(t_5 + t_6)$ ³⁾	DC	35	50	55	%	–

- 1) Not subject to production test, verified by design/characterization.
- 2) The PLL jitter characteristics add to this value according to the application settings. See the PLL jitter parameters.
- 3) The PLL jitter is not included in this parameter. If the BFCLKO frequency is equal to f_{CPU} , the K divider has to be regarded.

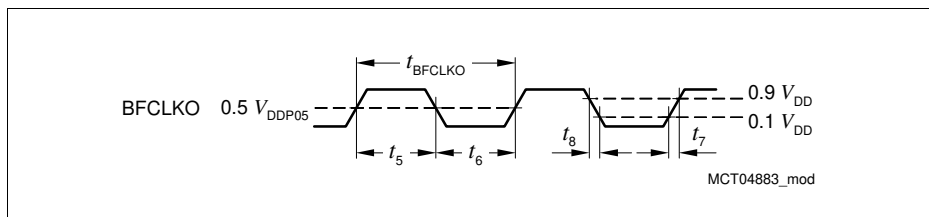

Figure 23 BFCLKO Output Clock Timing

5.3.12.2 EBU Asynchronous Timings

$V_{SS} = 0\text{ V}; V_{DD} = 1.3\text{ V} \pm 5\%$; $V_{DDEBU} = 2.5\text{ V} \pm 5\%$ and $3.3\text{ V} \pm 5\%$, Class B pins;
 $C_L = 35\text{ pF}$ for address/data; $C_L = 40\text{ pF}$ for the control lines.

For each timing, the accumulated PLL jitter of the programmed duration in number of clock periods must be added separately. Operating conditions apply and $C_L = 35\text{ pF}$.

Table 42 EBU Common Asynchronous Timings

Parameter	Symbol	Values			Unit	Note / Test Condition
		Min.	Typ.	Max.		
Pulse width deviation from the ideal programmed width due to B pad asymmetry, rise delay - fall delay ¹⁾	t_a CC	-0.8	–	0.8	ns	edge= medium
		-0.8	–	0.8	ns	edge= sharp
AD(31:0) output delay to ADV# rising edge, multiplexed read / write ¹⁾	t_{13} CC	-5.5	–	2	ns	
AD(31:0) output delay to ADV# rising edge, multiplexed read / write ¹⁾	t_{14} CC	-5.5	–	2	ns	
Address valid to CS falling edge (deviation from programmed value) ¹⁾	t_{15} CC	-2	–	2	ns	
Address valid to ADV falling edge (deviation from programmed value) ¹⁾	t_{16} CC	-2	–	2	ns	
ADV falling edge -> CS falling edge (deviation from programmed value) ¹⁾	t_{17} CC	-2	–	2	ns	

1) Not subject to production test, verified by design/characterization.

Table 43 EBU Asynchronous Read Timings

Parameter	Symbol	Values			Unit	Note / Test Condition
		Min.	Typ.	Max.		
A(23:0) output delay to RD rising edge, deviation from the ideal programmed value ¹⁾	t_0 CC	-2.5	–	2.5	ns	
A(23:0) output delay to RD rising edge, deviation from the ideal programmed value ¹⁾	t_1 CC	-2.5	–	2.5	ns	
CS rising edge to RD rising edge, deviation from the ideal programmed value ¹⁾	t_2 CC	-2	–	2.5	ns	
ADV rising edge to RD rising edge, deviation from the ideal programmed value ¹⁾	t_3 CC	-1.5	–	4.5	ns	
BC rising edge to RD rising edge, deviation from the ideal programmed value ¹⁾	t_4 CC	-2.5	–	2.5	ns	
WAIT input setup to RD rising edge, deviation from the ideal programmed value ¹⁾	t_5 SR	12	–	–	ns	
WAIT input hold to RD rising edge, deviation from the ideal programmed value ¹⁾	t_6 SR	0	–	–	ns	
Data input setup to RD rising edge, deviation from the ideal programmed value ¹⁾	t_7 SR	12	–	–	ns	

Electrical Parameters AC Parameters

Table 43 EBU Asynchronous Read Timings (cont'd)

Parameter	Symbol	Values			Unit	Note / Test Condition
		Min.	Typ.	Max.		
Data input hold to RD rising edge, deviation from the ideal programmed value ¹⁾	t_8 SR	-4	–	–	ns	
MR / W output delay to RD# rising edge, deviation from the ideal programmed value ¹⁾	t_9 CC	-2.5	–	1.5	ns	
Data input hold from CS rising edge ¹⁾	t_{18} CC	-4	–	–	ns	
Data input setup to CS rising edge ¹⁾	t_{19} CC	12	–	–	ns	

1) Not subject to production test, verified by design/characterization.

Electrical Parameters AC Parameters

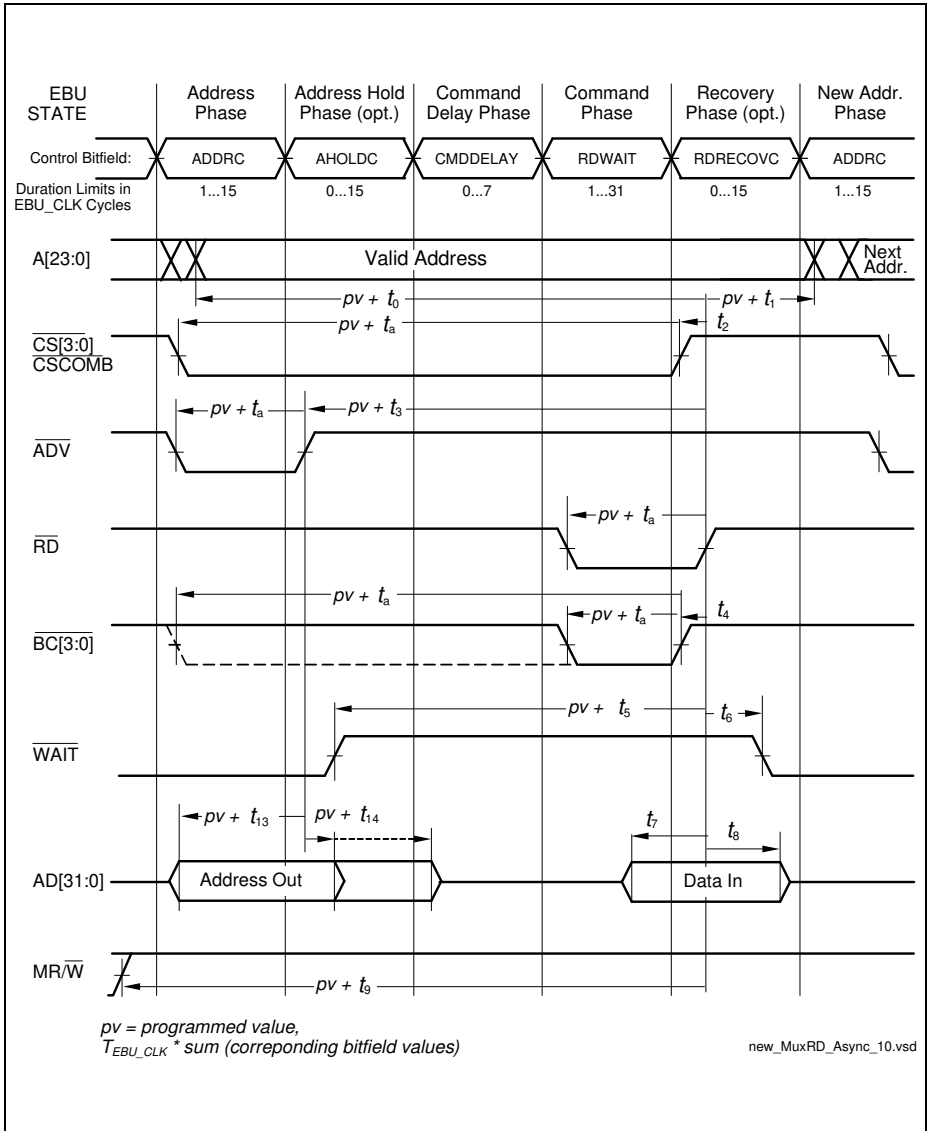

Figure 24 Multiplexed Read Access

Electrical Parameters AC Parameters

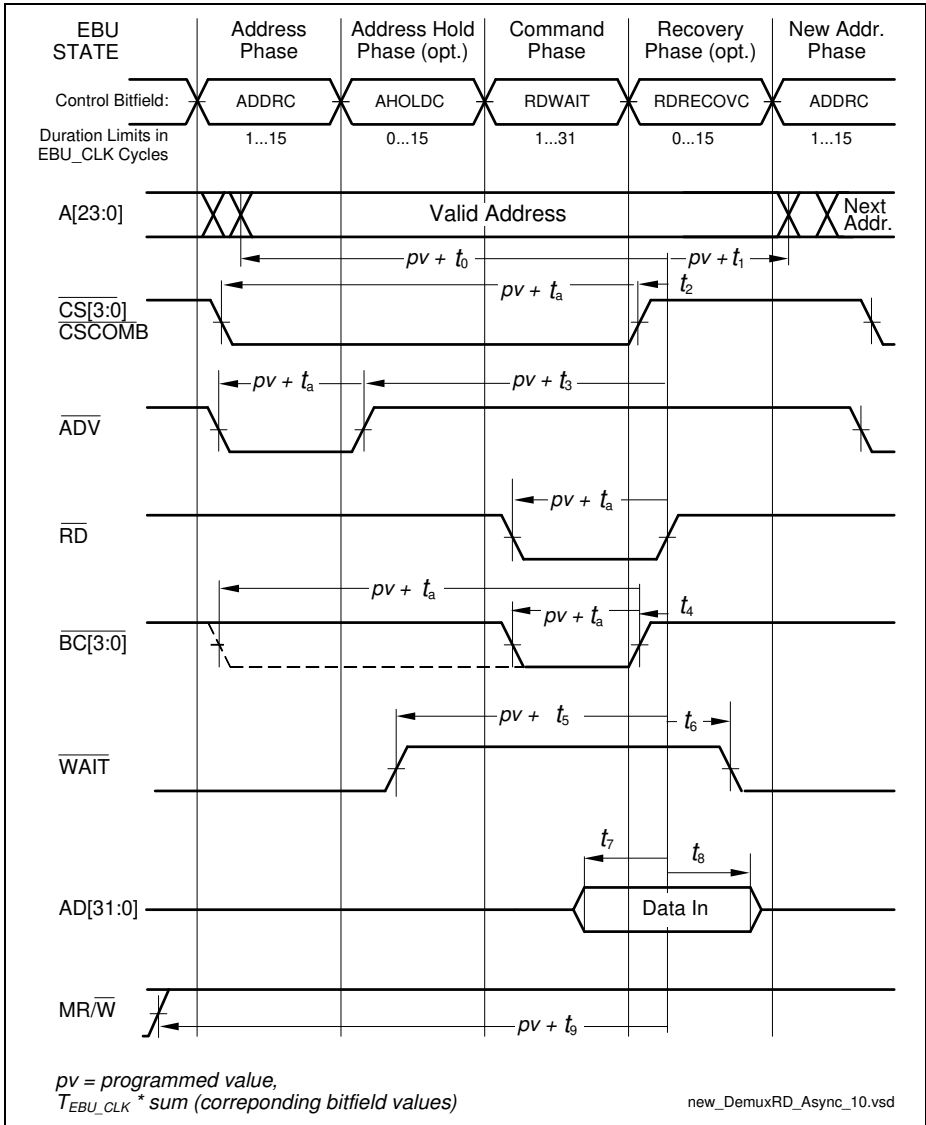

Figure 25 Demultiplexed Read Access

Table 44 EBU Asynchronous Write Timings

Parameter	Symbol	Values			Unit	Note / Test Condition
		Min.	Typ.	Max.		
A(23:0) output delay to WR rising edge, deviation from the ideal programmed value ¹⁾	t_{30} CC	-2.5	–	2.5	ns	
A(23:0) output delay to WR rising edge, deviation from the ideal programmed value ¹⁾	t_{31} CC	-2.5	–	2.5	ns	
CS rising edge to WR rising edge, deviation from the ideal programmed value ¹⁾	t_{32} CC	-2	–	2	ns	
ADV rising edge to WR rising edge, deviation from the ideal programmed value ¹⁾	t_{33} CC	-2.5	–	2	ns	
BC rising edge to WR rising edge, deviation from the ideal programmed value ¹⁾	t_{34} CC	-2.5	–	2	ns	
WAIT input setup to WR rising edge, deviation from the ideal programmed value ¹⁾	t_{35} SR	12	–	–	ns	
WAIT input hold to WR rising edge, deviation from the ideal programmed value ¹⁾	t_{36} SR	0	–	–	ns	
Data output delay to WR rising edge, deviation from the ideal programmed value ¹⁾	t_{37} CC	-5.5	–	2	ns	

Electrical Parameters AC Parameters

Table 44 EBU Asynchronous Write Timings (cont'd)

Parameter	Symbol	Values			Unit	Note / Test Condition
		Min.	Typ.	Max.		
Data output delay to WR rising edge, deviation from the ideal programmed value ¹⁾	t_{38} CC	-5.5	–	2	ns	
MR / W output delay to WR rising edge, deviation from the ideal programmed value ¹⁾	t_{39} CC	-2.5	–	1.5	ns	

1) Not subject to production test, verified by design/characterization.

Electrical Parameters AC Parameters

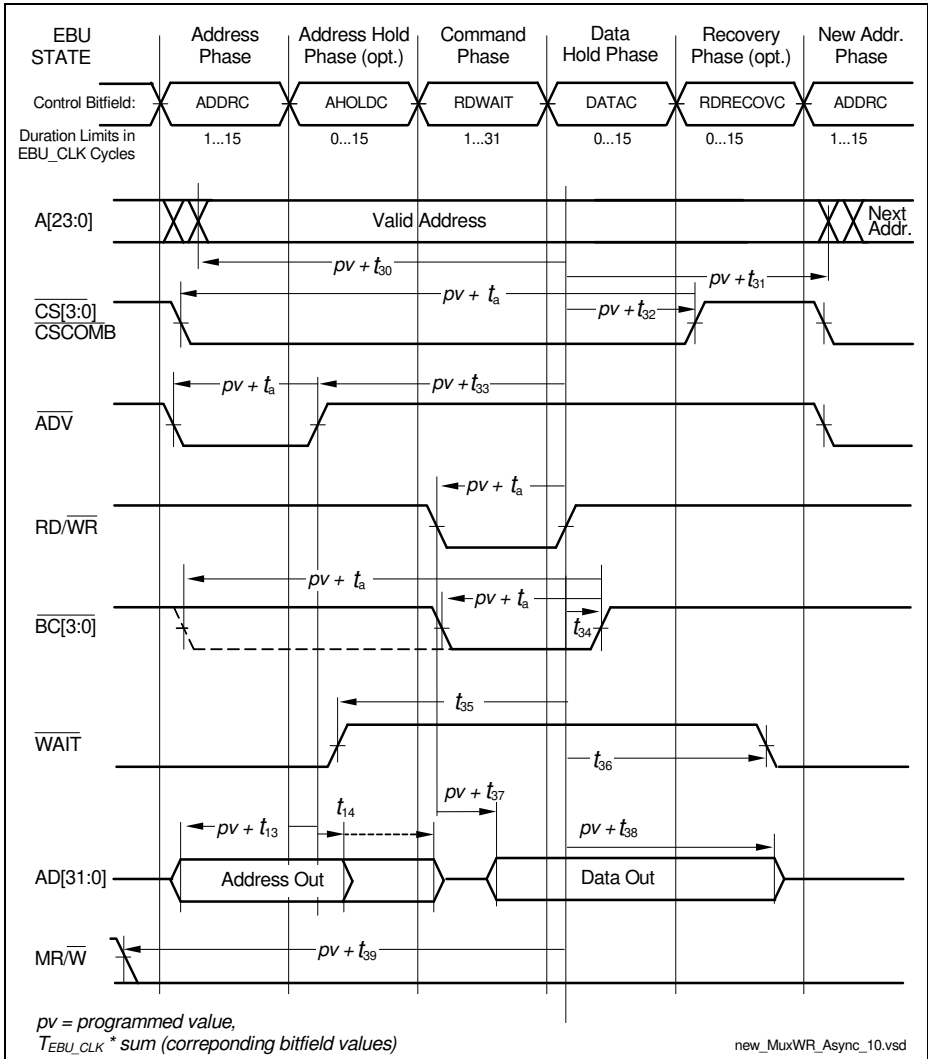

Figure 26 Multiplexed Write Access

Electrical Parameters AC Parameters

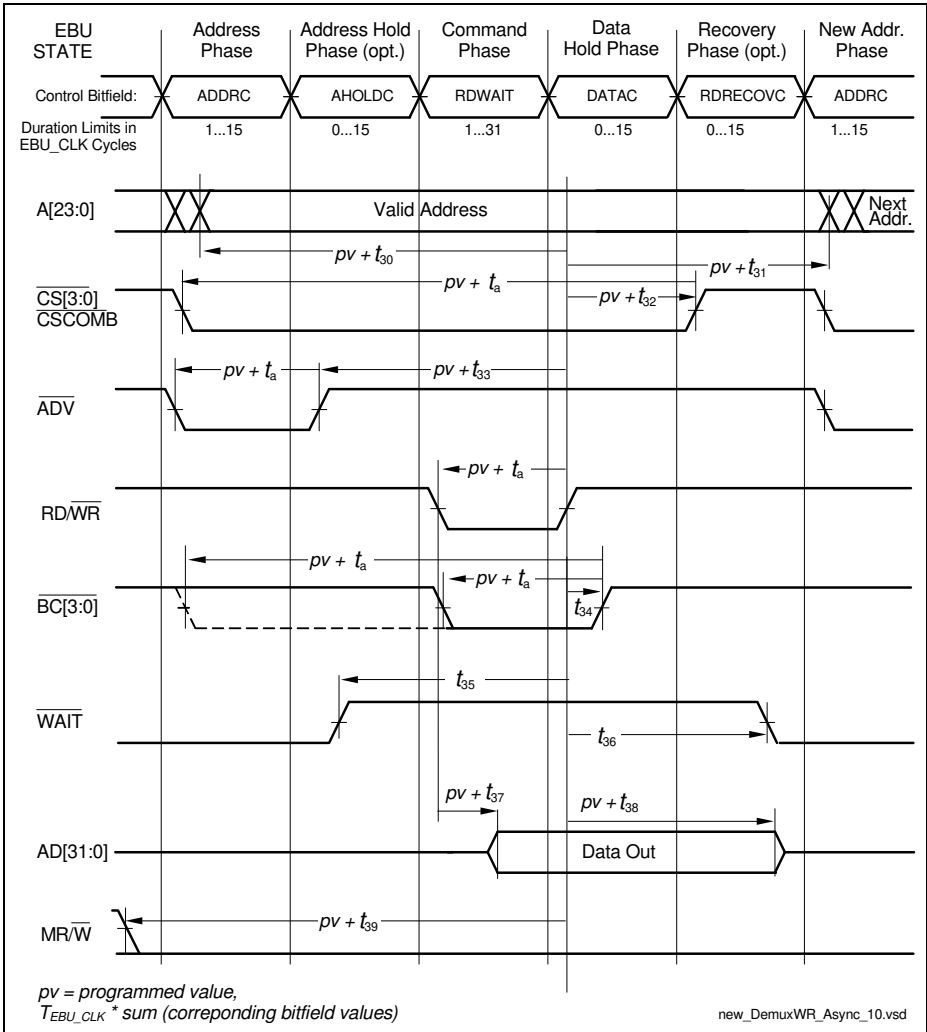

Figure 27 Demultiplexed Write Access

5.3.12.3 EBU Burst Mode Access Timing

$V_{SS} = 0\text{ V}; V_{DD} = 1.3\text{ V} \pm 5\%; V_{DDEBU} = 2.5\text{ V} \pm 5\%$ and $3.3\text{ V} \pm 5\%$, Class B pins;
 $C_L = 35\text{ pF}$;

Table 45 EBU Burst Read Timings

Parameter	Symbol	Values			Unit	Note / Test Condition
		Min.	Typ.	Max.		
Output delay from BFCLKO rising edge ¹⁾	t_{10} CC	-2	–	2	ns	
RD and RD/WR active/inactive after BFCLKO active edge ¹⁾²⁾	t_{12} CC	-2	–	2	ns	
CSx output delay from BFCLKO active edge ¹⁾²⁾	t_{21} CC	-2.5	–	1.5	ns	
ADV active/inactive after BFCLKO active edge ¹⁾³⁾	t_{22} CC	-2	–	2	ns	
BAA active/inactive after BFCLKO active edge ¹⁾³⁾	t_{22a} CC	-2.5	–	1.5	ns	
Data setup to BFCLKI rising edge ¹⁾	t_{23} SR	3	–	–	ns	
Data hold from BFCLKI rising edge ¹⁾	t_{24} SR	0	–	–	ns	
WAIT setup (low or high) to BFCLKI rising edge ¹⁾	t_{25} SR	3	–	–	ns	
WAIT hold (low or high) from BFCLKI rising edge ¹⁾	t_{26} SR	0	–	–	ns	

- 1) Not subject to production test, verified by design/characterization.
- 2) An active edge can be rising or falling edge, depending on the settings of bits BFCON.EBSE / ECSE and clock divider ratio. Negative minimum values for these parameters mean that the last data read during a burst may be corrupted. However, with clock feedback enabled, this value is oversampling not required for the LMB transaction and will be discarded. If the clock feedback is not enabled, the input signals are latched using the internal clock in the same way as at asynchronous access. So t_{14} , t_{15} , t_{16} , t_{17} , t_{18} and t_{19} from the asynchronous timings apply.
- 3) For BUSCONx.EBSE=1B and BUSAPx.EXLCLK=00B, ADV will change normally on the clock edge so this parameter is used directly.
 For BUSCONx.EBSE=1B and other values of BUSAPx.EXTCLK, ADV and BAA add the high pulse width of EBUCLK to this parameter.
 For BUSCONx.EBSE=0B and BUSAPx.EXTCLK=00B add the high pulse width of EBUCLK to this parameter.
 For BUSCONx.EBSE=0B and BUSAPx.EXTCLK=11B add two EBUCLK periodsto this parameter to get the hold time from BFCLKO rising edge to the ADV.
 For BUSCONx.EBSE=0B and BUSAPx.EXTCLK=01B or 10B add 1 EBUCLK period.
 Please note that the high pulse width of EBUCLK is defined by the high pulse width of fVCO of the used PLL.

Electrical Parameters AC Parameters

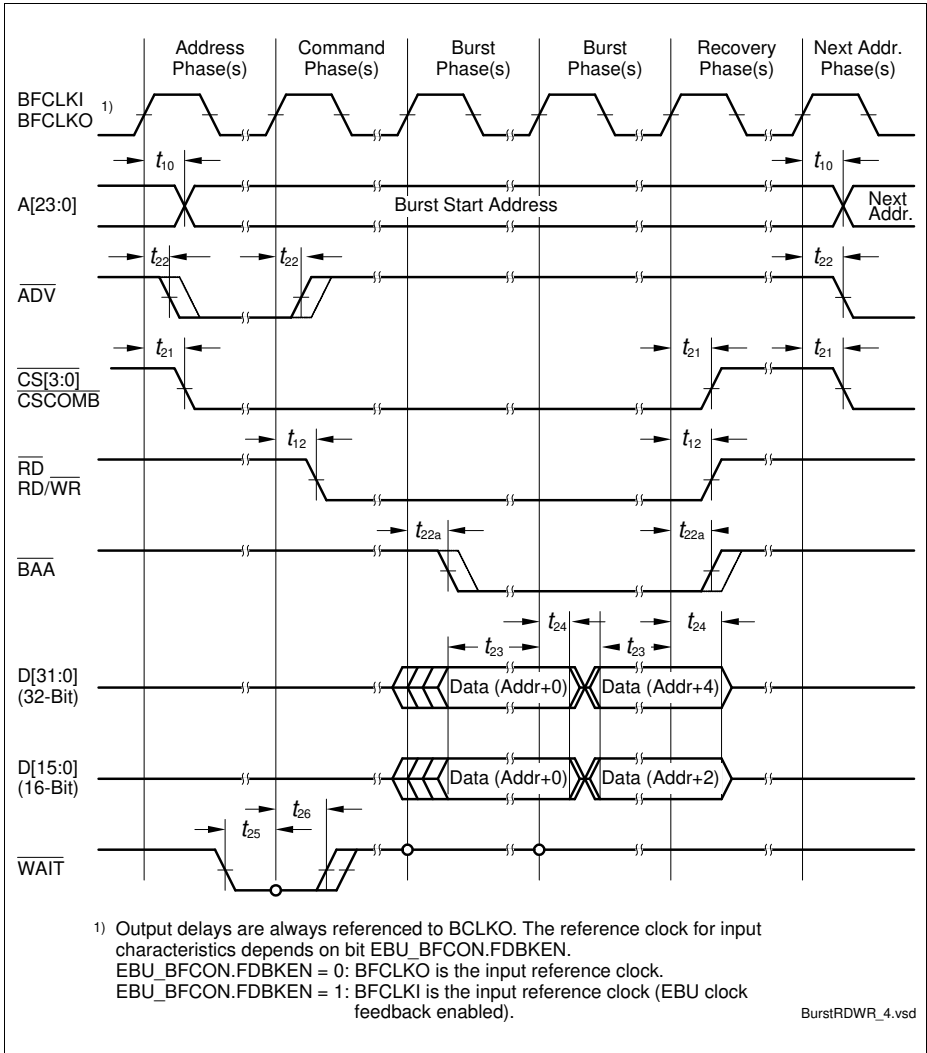

Figure 28 EBU Burst Mode Read / Write Access Timing

5.3.12.4 EBU Arbitration Signal Timing

$V_{SS} = 0\text{ V}; V_{DD} = 1.5\text{ V} \pm 5\%$; $V_{DDEBU} = 2.5\text{ V} \pm 5\%$ and $3.3\text{ V} \pm 5\%$, Class B pins;
 $T_A = -40^\circ\text{C}$ to $+125^\circ\text{C}$; $C_L = 35\text{ pF}$;

Table 46 EBU Arbitration Timings

Parameter	Symbol	Values			Unit	Note / Test Condition
		Min.	Typ.	Max.		
Output delay from BFCLKO rising edge ¹⁾	t_{27} CC	–	–	3	ns	
Data setup to BFCLKO falling edge ¹⁾	t_{28} SR	8	–	–	ns	
Data hold from BFCLKO falling edge ¹⁾	t_{29} SR	2	–	–	ns	

1) Not subject to production test, verified by design/characterization.

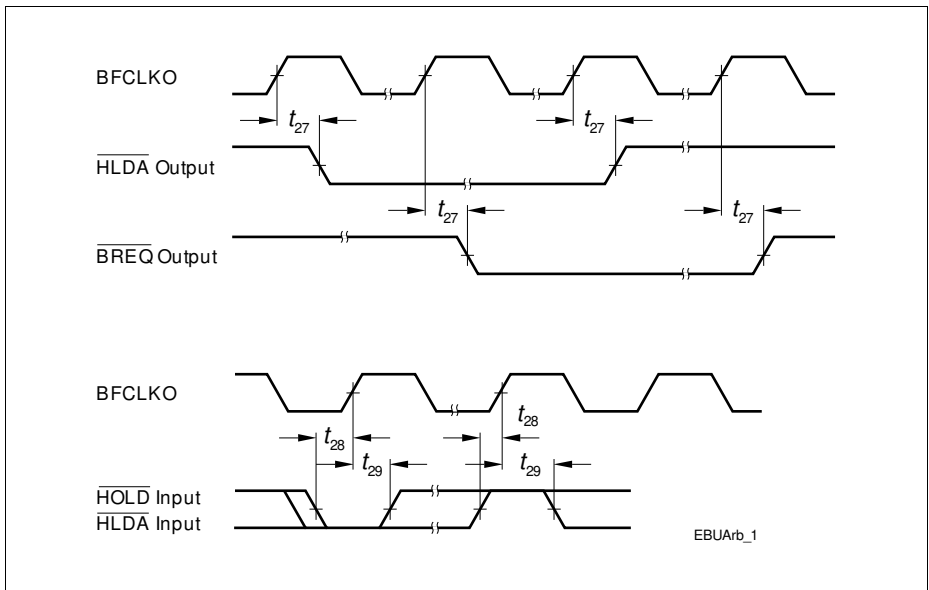

Figure 29 EBU Arbitration Signal Timing

Electrical Parameters Flash Memory Parameters

5.4 Flash Memory Parameters

The data retention time of the TC1793's Flash memory depends on the number of times the Flash memory has been erased and programmed.

Table 47 FLASH32 Parameters

Parameter	Symbol	Values			Unit	Note / Test Condition
		Min.	Typ.	Max.		
Data Flash Erase Time per Sector	t_{ERD} CC	–	–	4.2 ¹⁾	s	
Program Flash Erase Time per 256 KByte Sector	t_{ERP} CC	–	–	5	s	
Program time data flash per page ²⁾	t_{PRD} CC	–	–	5.3	ms	without reprogramming
		–	–	15.9	ms	with two reprogramming cycles
Program time program flash per page ³⁾	t_{PRP} CC	–	–	5.3	ms	without reprogramming
		–	–	10.6	ms	with one reprogramming cycle
Data Flash Endurance	N_E CC	60000 ⁴⁾	–	–	cycle s	Min. data retention time 5 years
Erase suspend delay	t_{FL_ErSusp} CC	–	–	15	ms	
Wait time after margin change	$t_{FL_MarginDel}$ CC	10	–	–	μs	
Program Flash Retention Time, Physical Sector ⁵⁾⁶⁾	t_{RET} CC	20	–	–	year s	Max. 1000 erase/program cycles
Program Flash Retention Time, Logical Sector ⁵⁾⁶⁾	t_{RETL} CC	20	–	–	year s	Max. 100 erase/program cycles
UCB Retention Time ⁵⁾⁶⁾	t_{RTU} CC	20	–	–	year s	Max. 4 erase/program cycles per UCB

Electrical Parameters Flash Memory Parameters

Table 47 FLASH32 Parameters (cont'd)

Parameter	Symbol	Values			Unit	Note / Test Condition
		Min.	Typ.	Max.		
Wake-Up time	t_{WU} CC	–	–	270	μ s	
DFlash wait state configuration	WS_{DF} CC	$50\text{ ns} \times f_{FSI}$	–	–		
PFlash wait state configuration	WS_{PF} CC	$26\text{ ns} \times f_{FSI}$	–	–		

- 1) In case of wordline oriented defects (see robust EEPROM emulation in the User's Manual) this erase time can increase by up to 100%.
- 2) In case the Program Verify feature detects weak bits, these bits will be programmed up to twice more. Each reprogramming takes additional 5 ms.
- 3) In case the Program Verify feature detects weak bits, these bits will be programmed once more. The reprogramming takes additional 5 ms.
- 4) Only valid when a robust EEPROM emulation algorithm is used. For more details see the User's Manual.
- 5) Storage and inactive time included.
- 6) At average weighted junction temperature $T_j = 100^\circ\text{C}$, or the retention time at average weighted temperature of $T_j = 110^\circ\text{C}$ is minimum 10 years, or the retention time at average weighted temperature of $T_j = 150^\circ\text{C}$ is minimum 0.7 years.

5.5 Package and Reliability

5.5.1 Package Parameters

Table 48 Thermal Characteristics of the Package

Device	Package	$R_{\Theta JCT}^{1)}$	$R_{\Theta JCB}^{1)}$	$R_{\Theta JA}$	Unit	Note
TC1793	PG-BGA- 416	3,3	4,5	12,1	K/W	

1) The top and bottom thermal resistances between the case and the ambient (R_{TCAT} , R_{TCAB}) are to be combined with the thermal resistances between the junction and the case given above (R_{TJCT} , R_{TJCB}), in order to calculate the total thermal resistance between the junction and the ambient (R_{TJA}). The thermal resistances between the case and the ambient (R_{TCAT} , R_{TCAB}) depend on the external system (PCB, case) characteristics, and are under user responsibility.

The junction temperature can be calculated using the following equation: $T_J = T_A + R_{TJA} \times P_D$, where the R_{TJA} is the total thermal resistance between the junction and the ambient. This total junction ambient resistance R_{TJA} can be obtained from the upper four partial thermal resistances.

Thermal resistances as measured by the 'cold plate method' (MIL SPEC-883 Method 1012.1).

5.5.2 Package Outline

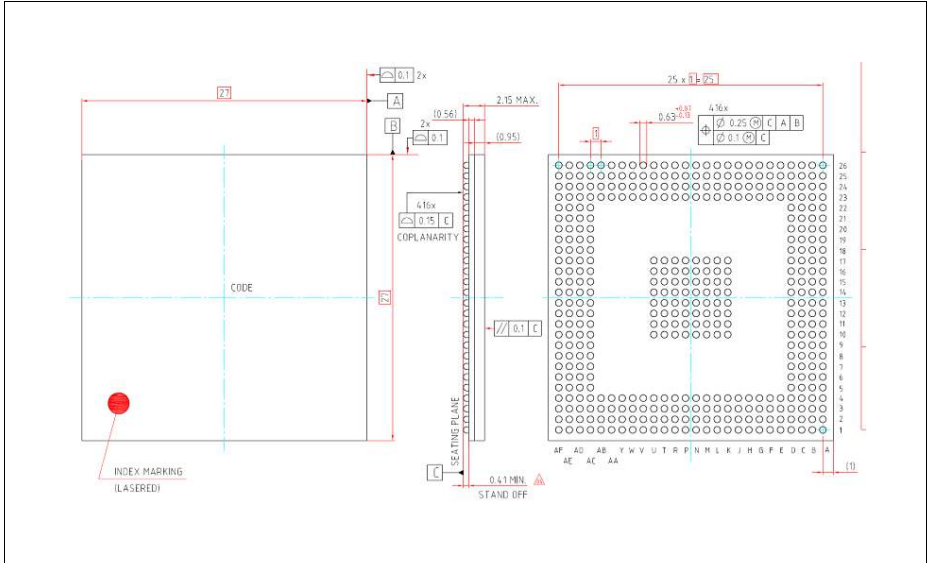

Figure 30 Package Outlines PG-BGA-416

You can find all of our packages, sorts of packing and others in our Infineon Internet Page “Products”: <http://www.infineon.com/products>.

5.5.3 Quality Declarations

Table 49 Quality Parameters

Parameter	Symbol	Values			Unit	Note / Test Condition
		Min.	Typ.	Max.		
Operation Lifetime ¹⁾	t_{OP}	—	—	24000	hours	— ²⁾
ESD susceptibility according to Human Body Model (HBM)	V_{HBM}	—	—	2000	V	Conforming to JESD22-A114-B
ESD susceptibility of the LVDS pins	V_{HBM1}	—	—	500	V	—

Electrical Parameters Package and Reliability

Table 49 Quality Parameters

Parameter	Symbol	Values			Unit	Note / Test Condition
		Min.	Typ.	Max.		
ESD susceptibility according to Charged Device Model (CDM)	V_{CDM}	–	–	500	V	Conforming to JESD22-C101-C
Moisture Sensitivity Level	MSL	–	–	3	–	Conforming to Jedec J-STD-020C for 240°C

1) This lifetime refers only to the time when the device is powered on.

2) For worst-case temperature profile equivalent to:

1200 hours at $T_j = 125...150^\circ\text{C}$

3600 hours at $T_j = 110...125^\circ\text{C}$

7200 hours at $T_j = 100...110^\circ\text{C}$

11000 hours at $T_j = 25...100^\circ\text{C}$

1000 hours at $T_j = -40...25^\circ\text{C}$

6 History

The following changes were done between Version 0.6 and 0.62 of this document:

- Change for port 1.7 the symbol from CC60INB to CC61INB for the CCU60 input
- Add footnote to port 4.1 alternate output 3 MTSR2
- change function description for port 4.1 alternate output 3 MTSR2 from Slave to Master Transmit
- Add footnote to port 6.4 alternate output 1 MTSR1
- Add footnote to port 7.1 alternate output 2 MTSR3
- Change for port 8.2 the symbol from CC61 (CCU60) to COUT63 (CCU61)
- Change for port 8.3 the symbol from OUT43 (GPTA1) to CC62 (CCU60)
- correct typo for port 9.4 from COUT&= to COUT60
- correct typo for port 9.5 from COUT&! to COUT61
- Change for port 15.4 and 15.5 the type from B1 to B
- Change for port 15 the type from S to D / S
- add clarification that table 11 defines the conditions for all other parameters
- add conditions for MLI, MSC, SSC, parameters
- add parameters dTx_{dly} and dRx_{dly} to ERAY parameters
- correct footnotes for ERAY parameters
- split flash parameters tPRD and tPRP in two conditions
- add conditions to LVDS pad parameters
- remove Pin Reliability in Overload section
- add parameters IIN and Sum IIN to absolute ratings
- add parameter HYSX to PSC_XTAL
- added RDSON values for all driver settings (weak, medium, and strong)
- removed footnote 2 of table 10
- change load for timing of SSC, MSC, and MLI from $C_L = 25$ pF to $C_L = 50$ pF (typical)
- add to parameters t_{RF} and t_{FF} condition $C_L = 50$ pF
- add new footnote 7) to ADC parameter table
- add min and max value for Q_{CONV} and adapt typ value
- add load conditions for t_{FF1} and t_{RF1}
- add conditions to PLL parameter t_L
- change DAP parameter t_{19} from SR to CC classification
- remove footnote 2 for the FADC
- adapt IDs for AB step
-
- removed footnote 2 in table 9
- change max value for ADC parameter t_S from 255 to 257
-

The following changes were done between Version 0.62 and 0.63 of this document:

- shift Output function CC62 of CCU60 for P8.3 from O3 to O2
- remove output function OUT43 for GPTA1 for P8.3

- add output function TData1 for MLI1 as O3 for P8.3
- remove O2 OUT105 for GPTA1 of P14.9
- add O2 T3OUT for GPT121 of P14.9
- changed the name for O3 from EVTO2 to EVTO1 for P0.5
- changed the name for O3 from EVTO3 to EVTO2 for P0.6
- changed the name for O3 from EVTO4 to EVTO3 for P0.7
- changed the name for O1 and O2 from OUT70 to OUT71 for P1.15
- add input function SLSI2 for SSC2 to P4.9
- change input function T13HRE from CCU60 to CCU63 for P3.14
- change for port 8.2 the symbol from CC61(CCU60) to COUT63(CCU61)
- change for port 14.10 the symbol from T3OUT(GPT120) to T6OUT(GPT121)
- add to all SSC signal the associated SSC module where is was missing in the pinning
- add section Pin Reliability in Overload
- increase values for absolute maximum parameters I_{IN} and $SumI_{IN}$
- correct P14.8 O2 as this was uncorrected label as O1

The following changes where done between Version 0.63 and 0.7 of this document:

- update value of RTID registers in section Identification Registers for AB step
- remove sentence 'Exposure to conditions within the maximum ratings will not affect device reliability. To replace this sentence section Pin Reliability in Overload was added.
- add footnote 1 to table 12 (Operating Conditions)
- increase values for absolute maximum parameters I_{IN} and $SumI_{IN}$
- remove capacitance conditions for LVDS pad parameters as loads are defined by interface (MSC) timings
- add parameter V_{ILSD} for class S pads
- add V_{DDM} supply limitation for class S parameters
- add footnote 10 to table 23 (ADC parameters)
- remove old footnote 2 from table 24 (FADC parameters)
- remove term typical from load of Peripheral Timings
- add definition of driver strength settings for ERAY Interface Timing
- update formulas for frequency modulation
- change SSC parameter from t_{59} CC to SR
- add figures for EBU Multiplexer and Demultiplexed Write Access
- change footnote 4 wording for ERAY timing back to TC1797 wording
- increase flash parameters t_{PRD} and t_{PRP} values
- increase flash parameter t_{ERD}
- add section 5.2.6.1.
- change in legende of table 2 definition of class S pad
- remove condition for V_{DDEBU}
- correct section Extended Range Operating Conditions for the 3.3 V area
- increase limit in Extended Range Operating Conditions from 1 hour to 1000 hours

History

- specify wording for limitation of pad performance in section Extended Range Operating Conditions
- remove incorrect test conditions for RDSONx parameters
- remove ADC 3 from ADC parameters
- adjust typo in temperature profile
- removed RDSON parameters for class F pads weak driver as only medium is available
- add parameter f_{SYSD} for the SYSPLL
- changed RDSON values for class F pads
- updated class B pads rise and fall times definitions
- add RDSON parameters to class B pads
- supply range of 1.8 V for V_{DDEBU} was removed
- update all current values of table 28 (Power Supply Parameters)
- rework the 3.3 V current part of the Power Supply Parameters for better description and usage
 - Parameters $I_{\text{DDP_FP}}$, I_{DDFL3E} and I_{DDFL3R} are removed and replaced in the following way
 - $I_{\text{DDP_FP}}$ is replaced by I_{DDP} with the condition including flash programming current
 - I_{DDFL3E} is replaced by I_{DDP} with the condition including flash erase verify current
 - I_{DDFL3R} is replaced by I_{DDP} with the condition including flash read current
 - parameter I_{DDFL3R} was renamed to I_{DDFL3}

The rework of the 3.3 V current part of the Power Supply Parameters was done for simplification and clarification. Former given values could still be used if liked, the new definition results in the same resulting values or slightly better values. The flash module is supplied via I_{DDFL3} and I_{DDP} . For the different flash operating modes in worst case different allocations for the two domains resulting.

The application typical case ‘flash read’ has max I_{DDP} of 25 mA and max I_{DDFL3} of 98 mA resulting is a sum of 123 mA.

The case ‘flash programming’ has max I_{DDP} of 55 mA and max I_{DDFL3} of 29 mA resulting is a sum of 84 mA.

The case ‘flash erase verify’ has max I_{DDP} of 40 mA and max I_{DDFL3} of 98 mA resulting is a sum of 138 mA.

So for the old parameter I_{DDP} with 35 mA, the new version reads as $I_{\text{DDP}} = 25 + I_{\text{DDP_PORST}} = 32$ mA for the same application relevant case.

The following changes were done between Version 0.7 and 1.0 of this document:

- improve parameters I_{DDFL3}
- change for parameter N_{E} note from Max. data retention to Min.
- change description of parameter t_{CAL} for the ADC
- correct typo for class D pads in tables 14 and 15
- adapt Absolute Maximum Rating
- add footnote to Flash parameter t_{ERD}

- add note at the end of Pin Reliability in Overload section
- clarify pad supply levels in Pin Reliability in Overload section
- add footnote for D-Flash currents in power section
- clarify wording for valid operating conditions
- add negative limit for class S pad leakage
- increase max values for parameter t_B
- change formula 10
- change MLI parameter t_{17} min value
- change footnote 3 for EBU parameter t_{22}
- change package naming
- add products SAK-TC1793N-512F270EF and SAK-TC1793N-512F270EB
- split FADC DNL parameter into two conditions and change value for gain 4 and 8
- update footnote 10 for the ADC
- update package outline
- update parameter description for SSC parameters t_{52} and t_{53}
- change SSC parameters from CC to SR Symbol for t_{56} , t_{57} , t_{58} and t_{59}
- increase value range for BFCLKO duty cycle

The following changes were done between Version 1.0 and 1.1 of this document:

- add product option SAK-TC1793S-512F270EF
- update block diagrams to cover new option
- add identification registers for new product option
- rework first sentence for chapter 5.3
- reduce min value for t_L for both PLLs
- split f_{VCC} for system PLL into two conditions
- add for MLI and SSC parameter: valid strong driver medium edge only
- add footnote 5) for SSC parameters
- add parameters t_{15} , t_{16} , t_{17} , and t_{19} to the EBU

The following changes were done between Version 1.1 and 1.1.1 of this document:

- update the incorrect CHIPID values for copper and non copper bond options.
- product SAK-TC-1793N-512F270EB not longer supported and replaced by SAK-TC1793N-512F270EF

www.infineon.com

Published by Infineon Technologies AG