

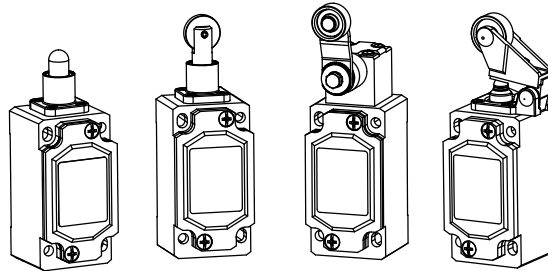

# Safety Limit Switches

## Datasheet

SI-LM40xxx Series Safety Limit (Position) Switches for Interlocking and Position Monitoring



- Limit-switch style (EN 50041 and Type 1 per ISO 14119) where actuating elements are integrated with the enclosure
-  Positive opening safety contacts (IEC 60947-5-1) (not dependent on springs)
- Can be used for safety or non-safety interlocking and position monitoring
- Choice of actuating systems: plunger, roller, spindle-mount lever, and lever styles
- Actuator head rotatable in 90° increments
- IP65 aluminum switch housing and cover
- Protected Earth Terminal (IEC 60947-1) on all models
- When properly interfaced or used with an appropriate controller, two switches monitoring an individual guard can achieve safety category 4, per ISO 13849-1 (EN 954-1)
- Typical applications include monitoring sliding (laterally) gates and guards on machines and in safety fencing systems

## Models

| Model        | Actuating System (See Figure)      | Contact Configuration | Switching Diagram                      |
|--------------|------------------------------------|-----------------------|--|
| SI-LM40PBD   | Plunger                            | One N.C. and one N.O. | See <a href="#">Figure 1</a> on page 5 |
| SI-LM40PBE   |                                    | Two N.C.              |  |
| SI-LM40PBF   |                                    | Two N.C. and one N.O. |  |
| SI-LM40RC18D | Roller                             | One N.C. and one N.O. | See <a href="#">Figure 2</a> on page 6 |
| SI-LM40RC18E |                                    | Two N.C.              |  |
| SI-LM40RC18F |                                    | Two N.C. and one N.O. |  |
| SI-LM40LA18D | Spindle-mount lever (18 mm roller) | One N.C. and one N.O. | See <a href="#">Figure 3</a> on page 7 |
| SI-LM40LA18E |                                    | Two N.C.              |  |
| SI-LM40LA18F |                                    | Two N.C. and one N.O. |  |
| SI-LM40L20D  | Lever (20 mm roller)               | One N.C. and one N.O. | See <a href="#">Figure 4</a> on page 8 |
| SI-LM40L20E  |                                    | Two N.C.              |  |
| SI-LM40L20F  |                                    | Two N.C. and one N.O. |  |



## Important... Read this before proceeding!

---

The user is responsible for satisfying all local, state, and national laws, rules, codes, and regulations relating to the use of this product and its application. Banner Engineering Corp. has made every effort to provide complete application, installation, operation, and maintenance instructions. Please contact a Banner Applications Engineer with any questions regarding this product.

The user is responsible for making sure that all machine operators, maintenance personnel, electricians, and supervisors are thoroughly familiar with and understand all instructions regarding the installation, maintenance, and use of this product, and with the machinery it controls. The user and any personnel involved with the installation and use of this product must be thoroughly familiar with all applicable standards, some of which are listed within the specifications. Banner Engineering Corp. makes no claim regarding a specific recommendation of any organization, the accuracy or effectiveness of any information provided, or the appropriateness of the provided information for a specific application.

## Overview

---

Use the SI-LM40xxx Series Safety Limit (Position) Switches to monitor the position of a guard to detect the movement, opening, or removal. A "guard" can be a gate, door, cover, panel, barrier or other physical means that separates an individual from a hazard. Safety switches will issue a signal to the machine control system to prevent or stop (halt) hazardous situations when the guard is not in the proper position. These Safety switches are designed for non-locking guarding applications, unless another means of locking is provided.

The SI-LM40xxx Series Safety Limit (Position) Switches are considered a Type 1 interlocking device per ISO 14119 that are mechanically actuated by an uncoded rotary or linear actuator (cam or "dog") typically mounted on or part of the guard. A variety of actuating systems are available: plunger (dome), roller plunger, spindle-mount lever roller, and lever.

## Installation Requirements

The following general requirements and considerations apply to the installation of interlocked gates and guards for the purpose of safeguarding. In addition, the user must refer to the relevant regulations and comply with all necessary requirements. See ANSI B11.19, or ISO 14119 and ISO 14120, or the appropriate standard.

Hazards guarded by the interlocked guard must be prevented from operating until the guard is closed; a stop command must be issued to the guarded machine if the guard opens while the hazard is present. Closing the guard must not, by itself, initiate hazardous motion; a separate procedure must be required to initiate the motion.

Locate the guard an adequate distance from the danger zone (so the hazard has time to stop before the guard is opened sufficiently to provide access to the hazard). Guard locking or supplemental safeguarding must be used if the overall stopping time of the machine or the time to remove the hazard is greater than the time to access the guarded area. The guard must open either laterally or away from the hazard, not into the safeguarded area. The guard also should not be able to close by itself and activate the interlocking circuitry. The installation must prevent personnel from reaching over, under, around or through the guard to access the hazard. Any openings due to positioning, movement, or misalignment in the guard must not allow access to the hazard—see ANSI B11.19, ISO 13855, ISO 13857, or the appropriate standard.

The guard must be strong enough and designed to protect personnel and contain hazards within the guarded area that can be ejected, dropped, or emitted by the machine. Mount them securely so that their physical position cannot shift, using reliable fasteners that require a tool to remove. Mounting slots in the housing, if provided, are for initial adjustment only; final mounting holes (round) must be used for permanent location. The switches, actuating systems, and actuators must not be used as a mechanical or end-of-travel stop.

The normally closed safety contacts are of a "positive-opening" design. Positive-opening operation causes the contacts to be forced open, without the use of springs, when the actuator is disengaged or moved from its home position. In addition, the switch(es) must be mounted in a "positive mode", to move/disengage the actuating system and actuator from its home position and open the normally closed contact, when the guard opens.

See *Mechanical Installation*, *Electrical Installation*, *Switching Diagrams*, and *Specifications* for additional information.

Design and install the safety switches and actuators so that they cannot be easily defeated. Measures to minimize defeat (bypassing) of interlocking safety switches include:

- Minimizing motivation for defeating interlocking by providing training, supervision, and efficient means for machine setup/adjustment, operation and maintenance
- Limiting accessibility to the interlocking device, such as mounting out of reach, mounting behind a physical obstruction, mounting in a concealed position
- Preventing actuation by readily available objects or tools
- Preventing the switch or the actuator from being disassembled or repositioned that compromises the safety function. (for example, welding, one-way screws, riveting)
- Control system monitoring of cyclic switch functioning and redundant means of interlocking
- Using hardware that requires a tool to remove that is not readily available.



**WARNING: Interlocked Guards**

The user must refer to the relevant regulations and comply with all necessary requirements. See ANSI B11.19, or ISO 14119 and ISO 14120, or the appropriate standard. At a minimum, the interlocked guard must prevent hazards when not fully closed and must also prevent access to the hazards through any opening in the guard. The safety switches and actuators must be designed and installed so that they cannot be easily defeated, and are not used as a mechanical or end-of-travel stop. At least one switch must be mounted in a positive mode and open the normally closed contact when the guard opens. Failure to follow these guidelines may result in serious bodily injury or death.



**CAUTION: End-of-Travel Stop**

Do not use the safety switch as a mechanical or end-of-travel stop.

The movement or rotation of the guard must be limited such that damage to the safety switch or the actuator cannot occur. Catastrophic damage can cause the safety switch to fail in an unsafe manner (that is, loss of the switching action).



**WARNING: Safety Distances and Safe Openings**

It must not be possible for personnel to reach any hazard through an opened guard or by reaching over, under, around, or through any opening in the guard before the hazardous situation has ceased. See ANSI B11.19 or ISO 14119, ISO 14120 and ISO 13857 for information on determining safety distances and safe opening sizes for your guarding device.

## Pass-through hazards and Perimeter Guarding

A pass-through hazard is associated with applications where personnel may pass through a safeguard (which issues a stop command to remove the hazard), and then continues into the guarded area, such as in perimeter guarding. Subsequently, their presence is no longer detected, and the related danger becomes the unexpected start or restart of the machine while personnel are within the guarded area.

Eliminate or reduce pass-through hazards whenever possible—see ANSI B11.19 and ANSI B11.20 or ISO 11161. One method to mitigate the risk is to ensure that once tripped, either the safeguarding device, the safety related part of the control system, or the guarded machine's MSCs/MPCEs will latch in an OFF condition. The latch must require a deliberate manual action to reset that is separate from the normal means of machine cycle initiation.

This method relies upon the location of the reset switch as well as safe work practices and procedures to prevent an unexpected start or restart of the guarded machine. All reset switches must be:

- Outside the guarded area
- Located to allow the switch operator a full, unobstructed view of the entire guarded area while the reset is performed
- Out of reach from within the guarded area
- Protected against unauthorized or inadvertent operation (such as through the use of rings or guards)

If any areas within the guarded area are not visible from the reset switch, additional safeguarding must be provided.



**WARNING: Pass-Through Hazards and Perimeter Guarding**

Lockout/Tagout procedures per ANSI Z244.1 may be required, or additional safeguarding, as described by ANSI B11.19 safety requirements or other appropriate standards, must be used if a passthrough hazard cannot be eliminated or reduced to an acceptable level of risk. Failure to observe this warning may result in serious bodily injury or death.

## Mechanical Installation



**Important:** Install a safety switch in a manner which discourages tampering or defeat. Mount switches to prevent bypassing of the switching function at the terminal chamber or Quick Disconnect (QD). A switch and its actuator must never be used as a mechanical stop. Overtravel may cause damage to switch.

All mounting hardware is supplied by the user. Fasteners must be of sufficient strength to guard against breakage. Use of permanent fasteners or locking hardware is recommended to prevent the loosening or displacement of the actuator and the switch body. The mounting holes in the switch body accept M5 screws.

Safety limit switches and their actuators (cams, dogs, etc.) must be mounted such that the position cannot be changed after installation/adjustment. Mount the switch securely on a solid, stationary surface that can accommodate the forces of actuator movement. The loosening of mounting hardware must be prevented (for example, lock washers, thread-locking compound). The use of slots should only be used for initial positioning. Pins, dowels, and splines can be used to prevent movement of the switch and the actuator (cam).

The safety limit switch must be installed to prevent false or unintended actuation and intentional defeat.

Safety limit switches should be located in such a manner that allows access for functional checks, maintenance, and service or replacement. The installation should provide suitable clearances, be readily accessible, and allow access to the actuator system (for example, roller lever) and switch body covers.

Safety limit switches should not be used in environments that subject the switch, the actuating system, or the actuator (cam) to extreme temperatures and vibration/shock or where excessive moisture (water, oils, coolants, etc.) or machining chips/swarf and dust can be reasonably expected.

## Actuating System and Actuator (Cam) Considerations

Actuating systems and actuators must be installed per the dimensioning diagram and the movement of the actuating system must remain within the specified operating range. The slope of the actuator (cam) must not be greater than specified and the construction material must be of sufficient hardness to ensure proper operation of the life time of the machine.

The actuating system must travel the required distance to operate the positive opening normally closed contacts, but not exceed the maximum travel listed on the switching diagrams. The installation must account for any mechanical inaccuracies, tolerance issues, wear, misalignment, etc. in the actuator (cam) and the actuating system of the switch by allowing sufficient post-travel after the positive opening point.

When used in a safety application, the actuating system must be operated by direct mechanical action (positive mode) of the actuator (cam) and the guard that engage the direct positive opening of the normally closed safety contacts. Non-direct mechanical action (negative mode) that relies on spring force should only be used in conjunction with a Type 1 or Type 2 (key/tongue actuated) interlocking switch mounted in the direct action positive mode as a redundant, complementary monitoring channel (see [Figure 5](#) on page 10).

Actuators (cams) must be designed and installed to:

- Ensure that the limit switch contacts are operated long enough to ensure that a proper signal is transmitted to operate connected devices or safety modules and controllers
- Ensure the actuator is not operated beyond its overtravel limits
- Ensure that the actuator does not receive severe impact from fast moving cams
- Ensure the actuator does not snap back into to position by an abrupt release
- Not use additional or modified actuators

Do not use the switch, actuating system, or the actuator (cam) as a mechanical end of travel stop. If you change the position of the actuator, ensure the correct reassembly for proper operation.

## Switching Diagrams

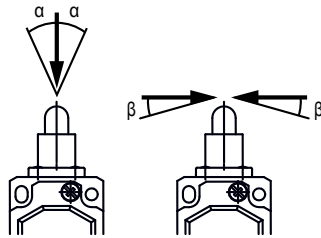
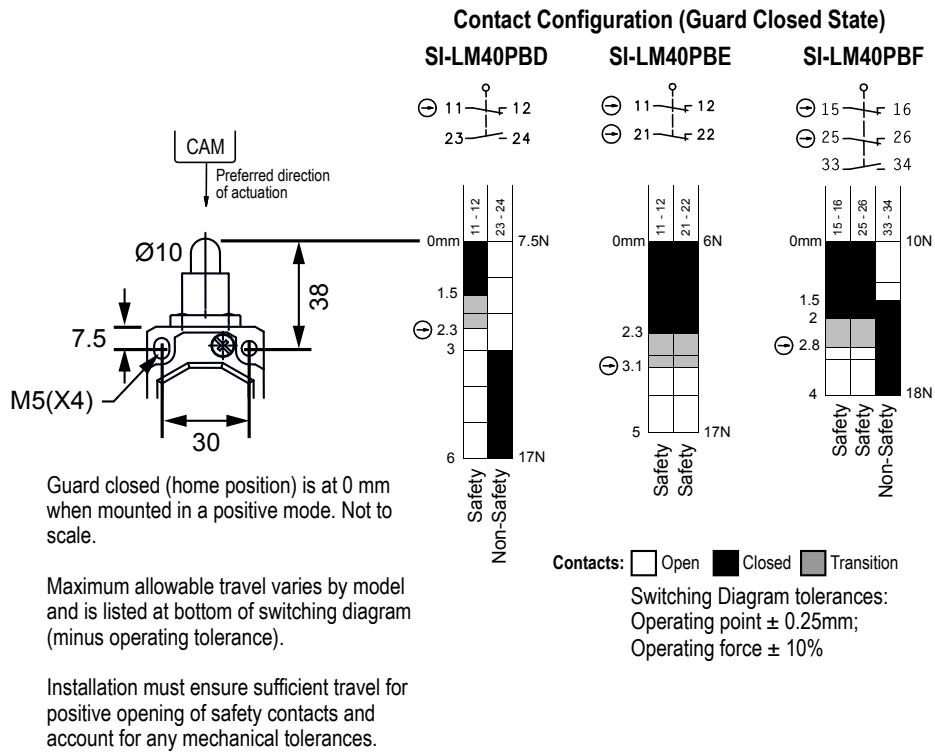

| Max. Approach speed vs. Max. Approach angle |         |         |       |       |       |
|---|---------|---------|-------|-------|-------|
|   | 0.1 m/s | 0.5 m/s | 1 m/s | 2 m/s | 5 m/s |
| $\alpha$                                    | 30°     | 5°      | -     | -     | -     |
| $\beta$                                     | 20°     | 20°     | 10°   | 5°    | -     |

Preferable direction of actuation is parallel to the plunger axis ( $\alpha^\circ$ ). Exceeding specified approach angle or speed can reduce life expectancy.

Figure 1. SI-LM40PBx Switching Diagrams



NOTE: This symbol for a positive-opening safety contact (IEC 60947-5-1) is used in the switching diagram to identify the point in actuator travel where the normally-closed safety contact is fully open.

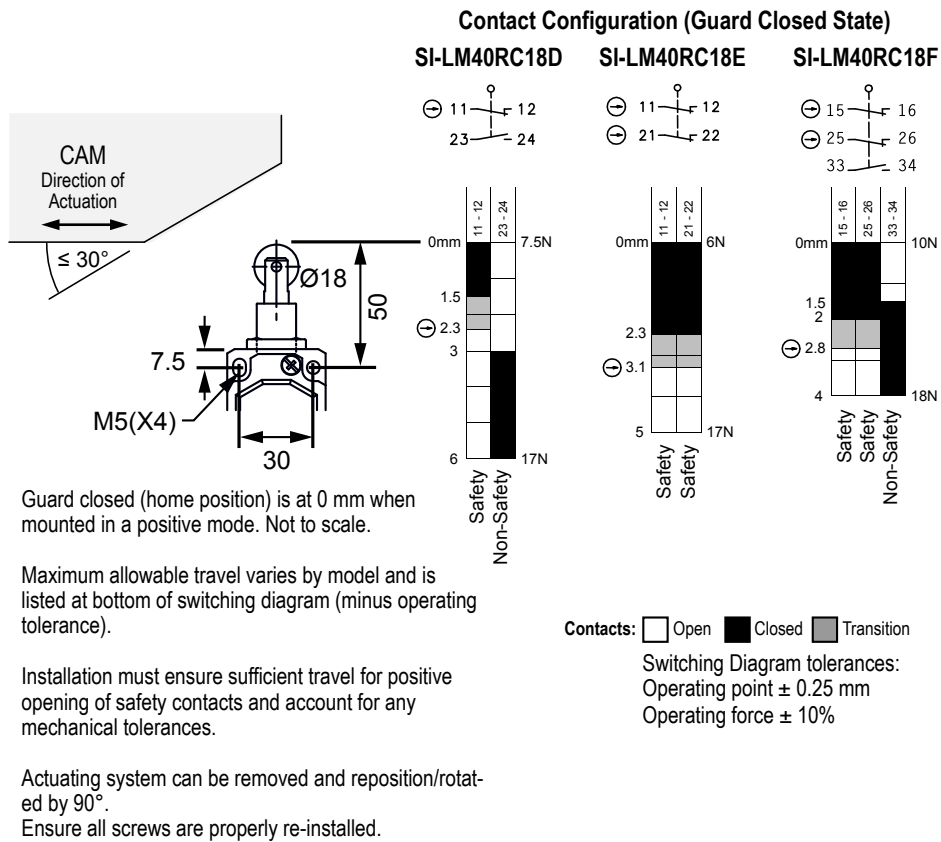

| Max. Approach speed vs. Max. Approach angle |            |            |            |            |           |
|---|------------|------------|------------|------------|-----------|
|   | 0.1 m/s    | 0.5 m/s    | 1 m/s      | 2 m/s      | 5 m/s     |
| $\beta$                                     | $30^\circ$ | $30^\circ$ | $20^\circ$ | $10^\circ$ | $5^\circ$ |

Direction of actuation is perpendicular to the actuating system axis. Exceeding specified approach angle or speed can reduce life expectancy.

Figure 2. SI-LM40RC18x Switching Diagrams



**NOTE:** This symbol for a positive-opening safety contact (IEC 60947-5-1) is used in the switching diagram to identify the point in actuator travel where the normally-closed safety contact is fully open.

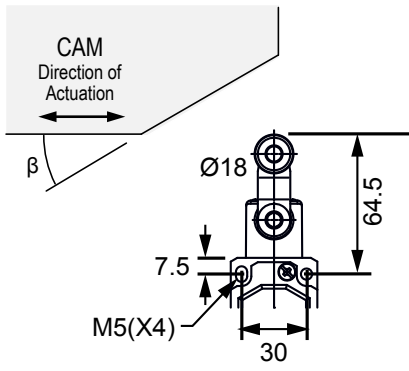
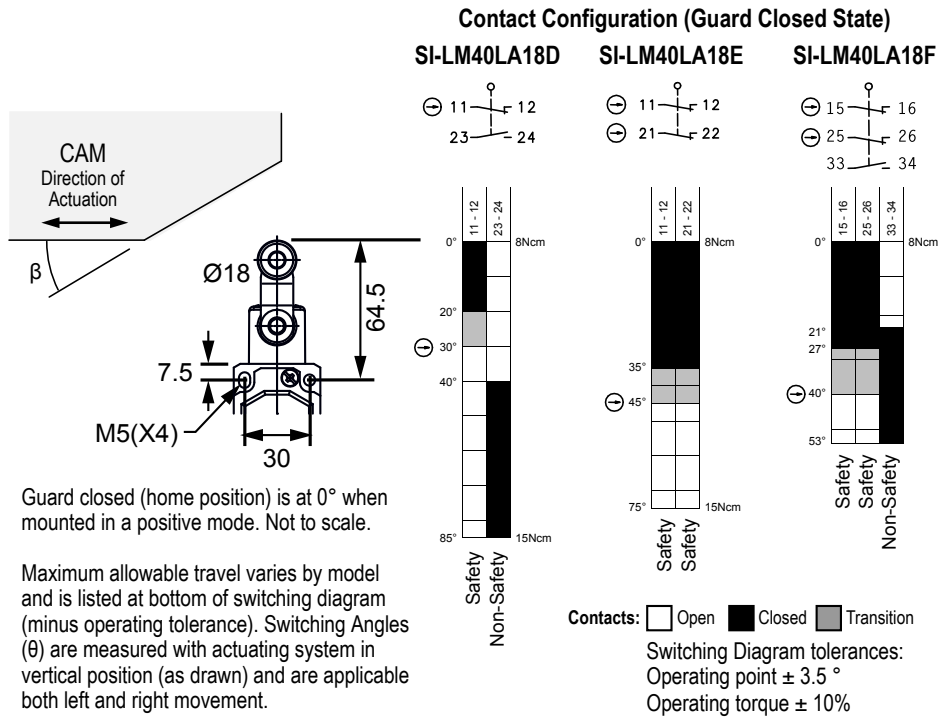

Guard closed (home position) is at 0° when mounted in a positive mode. Not to scale.

Maximum allowable travel varies by model and is listed at bottom of switching diagram (minus operating tolerance). Switching Angles ( $\theta$ ) are measured with actuating system in vertical position (as drawn) and are applicable both left and right movement.

Installation must ensure sufficient travel for positive opening of safety contacts and account for any mechanical tolerances.

Actuating system can be removed and reposition/rotated by 90° increments. Ensure all screws are properly re-installed.

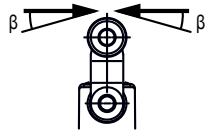

| Max. Approach speed vs. Max. Approach angle |         |         |       |       |       |
|---|---------|---------|-------|-------|-------|
|   | 0.1 m/s | 0.5 m/s | 1 m/s | 2 m/s | 5 m/s |
| $\beta$                                     | 45°     | 45°     | 45°   | 40°   | 30°   |

Direction of actuation is perpendicular to the actuating system axis. Exceeding specified approach angle or speed can reduce life expectancy.

Figure 3. SI-LM40LA18x Switching Diagrams



**NOTE:** This symbol for a positive-opening safety contact (IEC 60947-5-1) is used in the switching diagram to identify the point in actuator travel where the normally-closed safety contact is fully open.

**Contact Configuration (Guard Closed State)**

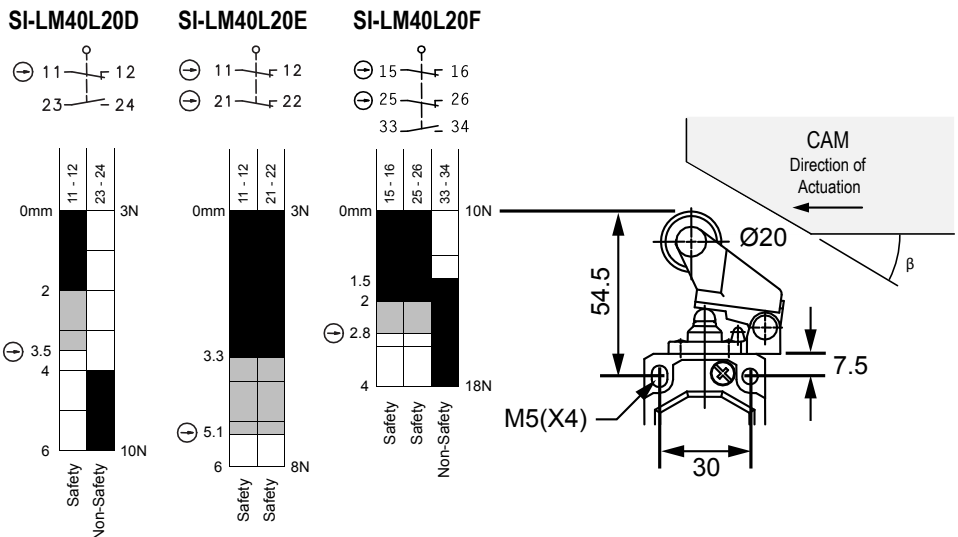

Contacts:  Open  Closed  Transition  
 Switching Diagram tolerances:  
 Operating point ± 0.25 mm  
 Operating force ± 10%

Guard closed (home position) is at 0 mm when mounted in a positive mode. Note to scale.

Maximum allowable travel varies by model and is listed at bottom of switching diagram (minus operating tolerance).

Installation must ensure sufficient travel for positive opening of safety contacts and account for any mechanical tolerances.

The actuator can only approach from the hinge side. Actuator can be removed and reposition/rotated by 90° increments. Ensure all screws are properly re-installed.

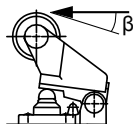

| Max. Approach speed vs. Max. Approach angle |         |         |       |       |       |
|---|---------|---------|-------|-------|-------|
|   | 0.1 m/s | 0.5 m/s | 1 m/s | 2 m/s | 5 m/s |
| β   | 40°     | 40°     | 30°   | 20°   | 10°   |

Direction of actuation is perpendicular to the actuating system axis and only from the hinge side of the actuator. Exceeding specified approach angle or speed can reduce life expectancy.

Figure 4. SI-LM40L20x Switching Diagrams



NOTE: This symbol for a positive-opening safety contact (IEC 60947-5-1) is used in the switching diagram to identify the point in actuator travel where the normally-closed safety contact is fully open.



## Electrical Installation



### WARNING: Shock Hazard and Hazardous Energy

Always disconnect power from the safety system (for example, device, module, interfacing, etc.) and the machine being controlled before making any connections or replacing any component.

Electrical installation and wiring must be made by Qualified Personnel<sup>1</sup> and must comply with the relevant electrical standards and wiring codes, such as the NEC (National Electrical Code), ANSI NFPA79, or IEC 60204-1, and all applicable local standards and codes.

Lockout/ tagout procedures may be required. Refer to OSHA 29CFR1910.147, ANSI Z244-1, ISO 14118, or the appropriate standard for controlling hazardous energy.

## Access to the Wiring Chamber

Access the wiring chamber by removing the two cover screws from the cover plate. A single M20 × 1.5 threaded port allows wiring to be routed via conduit or a cable gland. A conduit adapter is supplied to convert the M20 × 1.5 thread to ½" × 14 NPT. An accessory cable gland (SI-QM-CG20) that fits the M20 × 1.5 thread is available, see [Accessories](#) on page 13).

## Connection to a Machine

Perform a risk assessment to determine the appropriate level of safety circuit performance (integrity) and the means of interfacing the switch(es) with the machine control circuit. While Banner Engineering always recommends the highest level of safety in any application, the user is responsible to safely install, operate, and maintain each safety system and comply with all relevant laws and regulations.

To ensure the highest level of reliability (Control Reliable or Category 4, for example), wire the contacts from each of two individual safety switches per interlock guard in a dual channel hookup. At a minimum, one of these two contacts must be the positively-driven normally closed safety contact (S1 in [Figure 5](#) on page 10).

Depending on the application, the redundant switch contact will be a positively-driven normally closed safety contact (if mounted in a positive mode), or a normally open monitoring (non-safety) contact held closed by the cam on the guard (if mounted in a negative mode). In either scenario, the dual channel hookup is monitored by a safety module (for example, ES-FA-9AA), safety controller (for example, SC22-3 or SC/XS26-2), or the safety related part of the machine control that complies with the required level of safety performance.

<sup>1</sup> A person who, by possession of a recognized degree or certificate of professional training, or who, by extensive knowledge, training and experience, has successfully demonstrated the ability to solve problems relating to the subject matter and work.

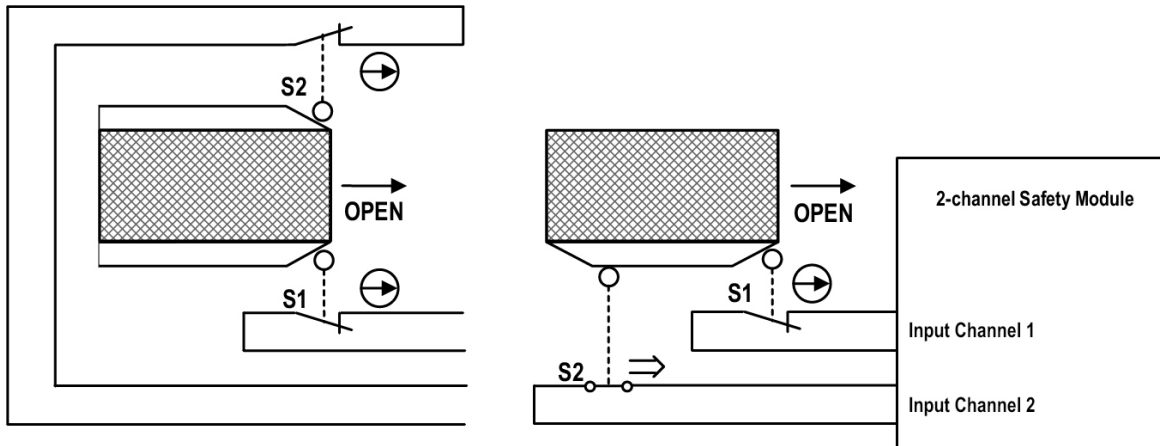

Normally closed safety contacts (11/12 or 21/22) are monitored by the safety module when both switches are mounted in the positive mode (that is, opening the guard actuates S1 and S2; circuit on left).

One normally closed safety contact (11/12 or 21/22) from the switch mounted in the positive mode (S1) and one normally open contact (23/24 or 33/34) from the switch mounted in the negative mode (S2) are monitored by the safety module (that is, opening the guard actuates S1 and releases S2; circuit on right).

Refer to the installation instructions provided with the safety module or safety controller for information regarding the interface to the machine stop control elements.

Figure 5. Connect two redundant safety switches per interlock guard to an appropriate 2-channel input safety module

Two functions of the safety module or safety controller are:

1. To provide a means of monitoring the contacts of both safety switches for contact failure, and to prevent the machine from restarting if either switch fails.
2. To provide a reset routine after closing the guard and returning the safety contacts to their closed position. This prevents the controlled machinery from restarting by simply closing the guard (reinserting the key/actuator, for example). This necessary reset function is required by ANSI B11.0, ANSI/NFPA 79, and IEC 60204-1 machine safety standards.



#### WARNING: Safety Circuit Integrity

A risk assessment must be performed to determine the appropriate safety circuit integrity level or category to ensure the expected risk reduction is achieved and all relevant regulations and standards are met (see ANSI B11.0 and ANSI B11.19, ISO 12100 and ISO13849-1 or the appropriate standards).



#### Important:

The design, installation, and the means of interfacing of the safety switches greatly impact the level of safety circuit integrity. It is recommended that two individual safety switches be used to monitor each guard and that at least one normally-closed safety contact and an additional contact, depending on the application, must be connected in a dual channel method to a safety module or safety controller to achieve control reliability (ANSI B11.19) or Category 3 or 4 (ISO 13849-1, EN 954-1). This is required to provide monitoring for safety switch failure, and to provide the necessary reset routine, as required by NFPA 79 and IEC 60204-1. Use of only one safety switch per interlock guard is not recommended in situations that can result in serious injury or death.

## Monitoring Series-Connected Safety Switches

When monitoring the position of several guards with a single safety module or controller, the contacts of the corresponding pole of each switch must be connected together in series. Never connect the contacts of multiple switches in parallel. Such a parallel connection can defeat the switch contact monitoring ability of the module and could create an unsafe condition.

When multiple safety switches are series connected, the failure of one switch in the system may be masked or not be detected at all. The following two scenarios assume two positive-opening safety switches on each guard, both connected in series to switches of a second guard (dual channel hookup) and monitored by a safety module or safety controller:

- **Masking of a failure**—If a guard is opened but one switch fails to open, the redundant safety switch on that guard opens and a protective (safety) stop occurs. If the faulty guard is then closed, the module/controller will not reset because one channel did not open, thus complying with the required fault detection. However, if a second "good"

guard is cycled (opening and then closing both of the channels), the failure appears to be corrected (input requirements satisfied) and the module/controller allows a reset. This system is no longer redundant and, if the second switch fails, may result in an unsafe condition (the accumulation of faults resulting in loss of the safety function).

- Non-detection of a failure—If a functional guard is opened, both channels open and the module/controller initiates a protective (safety) stop. If a guard with a faulty safety switch is then opened and closed before the good guard is re-closed, the faulty switch is not detected. The system is no longer redundant and may result in a loss of safety if the redundant switch fails to open when needed.

The system in either scenario does not inherently comply with the safety standard requirements of detecting a single fault and preventing the next cycle (not a Category 4 application per ISO 13849-1). In multiple-guard systems using series-connected safety switches, it is important to periodically check the functional integrity of each interlocked guard individually. Open and close each guard separately while verifying that the machine properly responds. Operators, maintenance personnel, and others associated with the operation of the machine must be trained to recognize failures and be instructed to correct them immediately.



#### WARNING: Series Connection of Safety Switches

Monitoring multiple guards with a series connection of safety interlock switches may result in a failure being masked or not detected at all. When such a configuration is used, periodic checks must be performed regularly to verify proper operation. All failures must be immediately corrected (for example, immediately replacing a failed switch), or the loss of the safety stop signal or an inappropriate reset may lead to serious injury or death.

## Maintenance

### Checkout

At switch installation or replacement and at machine set up, a *Designated Person*<sup>2</sup> must test each switch for proper machine shutdown response and check the switch(es) and installation for proper operation, physical damage, mounting (looseness), and excessive environmental contamination. This must also take place on a periodic schedule determined by the user, based on the severity of the operating environment and the frequency of switch actuations. Adjust, repair, or replace components as needed. If inspection reveals contamination on the switch, thoroughly clean the switch and eliminate the cause of the contamination. Replace the switch and/or appropriate components when any parts or assemblies are damaged, broken, deformed, or badly worn; or if the electrical/mechanical specifications (for the environment and operating conditions) have been exceeded. Always test the control system for proper functioning under machine control conditions after performing maintenance, replacing the switch, or replacing any component of the switch.

Additional items that should be included in the checkout and/or regularly scheduled maintenance of a safety limit switch, actuating system, and actuator (cam) are:

- Verify proper positioning of switch, actuating system (for example, roller lever), and cam or dog
- Verify correct switching function (actuator system has free movement and within switching distance specifications)
- Correct any misalignment or overrun between the actuator and the actuator system

### Repairs

Do not attempt any repairs to the safety interlocking switch. It contains no field-replaceable components. Return it to Banner Engineering for warranty repair or replacement.

Contact Banner Factory Application Engineering. They will attempt to troubleshoot the system from your description of the problem. If they conclude that a component is defective, they will issue a return merchandise authorization (RMA) number for your paperwork, and give you the proper shipping address.



Important: Pack the safety switches carefully. Damage that occurs in return shipping is not covered by warranty.

<sup>2</sup> A *Designated Person* is identified in writing by the employer as being appropriately trained to perform a specified checkout procedure.

## Specifications

### UL/ CSA Contact Rating

SI-LM40xxD: A300 (same polarity): 3 A at 240 V ac, 6 A at 120 V ac  
 SI-LM40xxE: A300 (same polarity): 3 A at 240 V ac, 6 A at 120 V ac  
 SI-LM40xxF: B300 (same polarity): 1.5 A at 240 V ac, 3 A at 120 V ac

### European Rating, Utilization categories (IEC/ EN 90497-5-1):

SI-LM40xxD:  $U_i = 400$  V ac,  $I_{th} = 10$  A, AC15  $U_e/I_e$  240 V/3 A, 120 V/6 A  
 SI-LM40xxE:  $U_i = 400$  V ac,  $I_{th} = 10$  A, AC15  $U_e/I_e$  240 V/3 A, 120 V/6 A  
 SI-LM40xxF:  $U_i = 250$  V ac,  $I_{th} = 5$  A, AC15  $U_e/I_e$  240 V/1.5 A, 120 V/3 A

### Electrical Protection Class

I

### Contact Function

Slow-action make and break contacts. See Switching Diagrams.

### Switching Frequency

≤ 100 per minute

### Contact Material

Silver-nickel alloy

### Mechanical Life

SI-LM40xxD:  $10 \times 10^6$  operations  
 SI-LM40xxE:  $1 \times 10^6$  operations  
 SI-LM40xxF:  $1 \times 10^6$  operations

### B10d

SI-LM40xxD:  $20 \times 10^6$  cycles (N.C. contact)  
 SI-LM40xxE:  $2 \times 10^6$  cycles (N.C. contact)  
 SI-LM40xxF:  $2 \times 10^6$  cycles (N.C. contact)

### Short Circuit Protection

Recommended external fusing or overload protection.

SI-LM40xxD: 10 amp Slow Blow  
 SI-LM40xxE: 6 amp Slow Blow  
 SI-LM40xxF: 6 amp Slow Blow

### Wire Connections

Screw terminals with pressure plates accept the following wire sizes. Ferrules are recommended for stranded wire.

Stranded and solid: 0.5 mm<sup>2</sup> (20 AWG) to 1.5 mm<sup>2</sup> (16 AWG) for one wire

Stranded: 0.5 mm<sup>2</sup> (20 AWG) to 1.0 mm<sup>2</sup> (18 AWG) for two wires

Maximum Tightening Torque

SI-LM40xxD: 0.9 N·m  
 SI-LM40xxE: 0.6 N·m  
 SI-LM40xxF: 0.6 N·m

### Cable Entry

One M20 × 1.5 threaded entrance. Adapter supplied to convert M20 × 1.5 to 1/2" - 14 NPT threaded

### Construction

Enclosure: Die-case aluminum

Cover: Aluminum

Actuator:

SI-LM40PBx (Plunger): Steel

SI-LM40RC18x (10 mm Roller): Steel

SI-LM40LA18x (Spindle-mount Lever with 18 mm roller): Head: Zinc Die-Case, Level: Steel, Roller: Thermoplastic

SI-LM40L20x (Lever with 11 mm roller): Level: Zinc Die-Cast, Roller: Thermoplastic

### Environmental Rating

IEC IP65 according to IEC/EN 60529

The degree of protection (IP code) specified applies solely to a properly closed cover and the use of an equivalent cable gland with adequate cable.

### Operating Conditions

−30 °C to +80 °C (−34 °F to +176 °F)

### Mounting

4 × M5 screws DIN 912 (on a flat and stiff surface)

### Weight (approximate)

SI-LM40PBx: 0.20 kg  
 SI-LM40RC18x: 0.20 kg  
 SI-LM40LA18x: 0.28 kg  
 SI-LM40L20x: 0.23 kg

### Applicable Standards

VDE 0660 T100, DIN EN 60947-1, IEC 60947-1  
 VDE 0660 T200, DIN EN 60947-5-1, IEC 60947-5-1  
 DIN EN ISO 13849-1

### Approvals

SI-LM40xxD: cCSA<sub>US</sub> A300 (same polarity)  
 SI-LM40xxE: cCSA<sub>US</sub> A300 (same polarity)  
 SI-LM40xxF: cCSA<sub>US</sub> B300 (same polarity)

### Certifications



## Dimensions

All measurements are listed in millimeters (inches), unless noted otherwise.

**SI-LM40PBx**

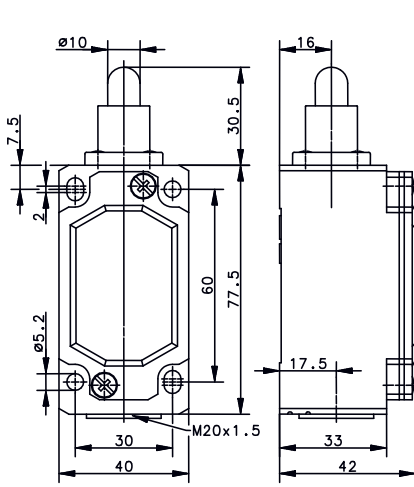

**SI-LM40RC18x**

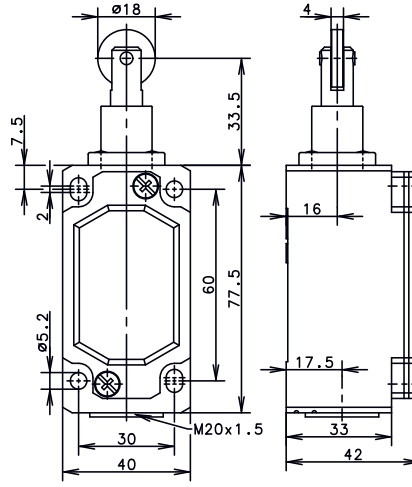

**SI-LM40LA18x**

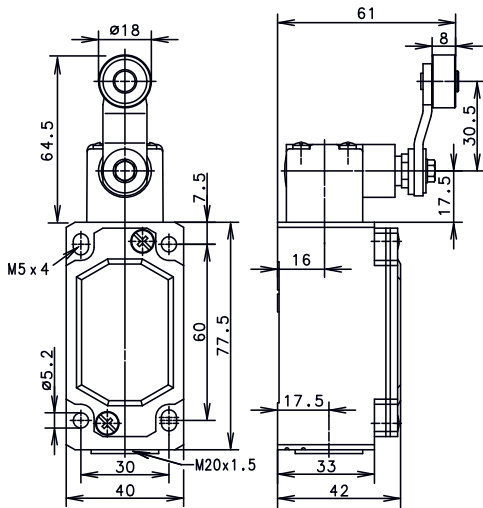

**SI-LM40L20Dx**

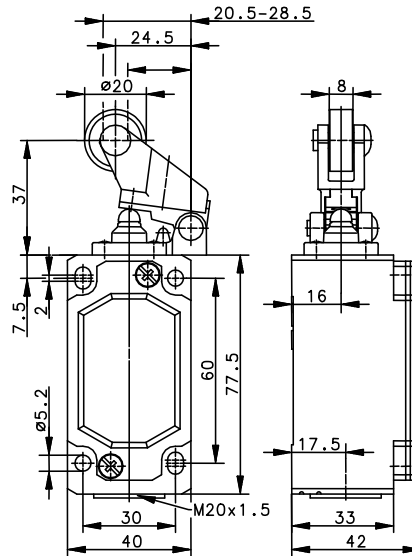

## Accessories

| Model       | Size            | For Cable Diameter                      | Dimensions | Used With   |
|-------------|-----------------|---|------------|---|
| SI-QM-CGM20 | M20 × 1.5 Metal | 5.0 to 12.0 mm<br>(0.20 to 0.47 inches) |            | SI-LM40 Safety Interlock Switches<br>SI-QM100 Safety Interlock Switches<br>RP-RM83 Rope Pull Switches<br>RP-LM40 Rope Pull Switches<br>RP-QM72/QMT72 Rope Pull Switches<br>RP-QM90 Rope Pull Switches |

| Model     | Size                 | Thread Conversion           | Dimensions | Used With  |
|-----------|----------------------|-----------------------------|------------|--|
| SI-QM-M20 | ½ in-14 NPT<br>Metal | M20 × 1.5 to ½<br>in-14 NPT |            | SI-LM40 Safety Interlock<br>Switches<br>SI-QM100 Safety Interlock<br>Switches<br>RP-RM83 Rope Pull Switches<br>RP-LM40 Rope Pull Switches<br>RP-QM72/QMT72 Rope Pull<br>Switches<br>RP-QM90 Rope Pull Switches |

One conduit adapter is supplied with each switch.

## Standards and Regulations

*The list of standards below is included as a convenience for users of this Banner device. Inclusion of the standards below does not imply that the device complies specifically with any standard, other than those specified in the Specifications section of this manual.*

### U.S. Application Standards

ANSI B11.0 Safety of Machinery; General Requirements and Risk Assessment

ANSI B11.19 Performance Criteria for Safeguarding

ANSI NFPA 79 Electrical Standard for Industrial Machinery

### International/ European Standards

- ISO 12100 Safety of Machinery – General Principles for Design — Risk Assessment and Risk Reduction
- ISO 14119 (EN 1088) Interlocking Devices Associated with Guards – Principles for Design and Selection
- ISO 14120 Safety of machinery – Guards – General requirements for the design and construction of fixed and movable guards
- ISO 13857 Safety Distances . . . Upper and Lower Limbs
- IEC 62061 Functional Safety of Safety-Related Electrical, Electronic and Programmable Control Systems
- ISO 13849-1 (EN 954-1) Safety-Related Parts of Control Systems
- IEC 60204-1 Electrical Equipment of Machines Part 1: General Requirements
- IEC 60947-1 Low Voltage Switchgear – General Rules
- IEC 60947-5-1 Low Voltage Switchgear – Electromechanical Control Circuit Devices
- IEC 60529 Degrees of Protection Provided by Enclosures
- IEC 61508 Functional Safety of Electrical/Electronic/Programmable Electronic Safety-Related Systems

## EC Declaration of Conformity (DoC)

Banner Engineering Corp. herewith declares that the SI-LM40xxx Series Safety Limit (Position) Switches are in conformity with the provisions of the Machinery Directive 2006/95/EC and all essential health and safety requirements have been met.

Representative in EU: Peter Mertens, Managing Director Banner Engineering Europe. Address: Park Lane, Culliganlaan 2F, 1831 Diegem, Belgium.

## Banner Engineering Corp Limited Warranty

Banner Engineering Corp. warrants its products to be free from defects in material and workmanship for one year following the date of shipment. Banner Engineering Corp. will repair or replace, free of charge, any product of its manufacture which, at the time it is returned to the factory, is found to have been defective during the warranty period. This warranty does not cover damage or liability for misuse, abuse, or the improper application or installation of the Banner product.

THIS LIMITED WARRANTY IS EXCLUSIVE AND IN LIEU OF ALL OTHER WARRANTIES WHETHER EXPRESS OR IMPLIED (INCLUDING, WITHOUT LIMITATION, ANY WARRANTY OF MERCHANTABILITY OR FITNESS FOR A PARTICULAR PURPOSE), AND WHETHER ARISING UNDER COURSE OF PERFORMANCE, COURSE OF DEALING OR TRADE USAGE.

This Warranty is exclusive and limited to repair or, at the discretion of Banner Engineering Corp., replacement. IN NO EVENT SHALL BANNER ENGINEERING CORP. BE LIABLE TO BUYER OR ANY OTHER PERSON OR ENTITY FOR ANY EXTRA COSTS, EXPENSES, LOSSES, LOSS OF PROFITS, OR ANY INCIDENTAL, CONSEQUENTIAL OR SPECIAL DAMAGES RESULTING FROM ANY PRODUCT DEFECT OR FROM THE USE OR INABILITY TO USE THE PRODUCT, WHETHER ARISING IN CONTRACT OR WARRANTY, STATUTE, TORT, STRICT LIABILITY, NEGLIGENCE, OR OTHERWISE.

Banner Engineering Corp. reserves the right to change, modify or improve the design of the product without assuming any obligations or liabilities relating to any product previously manufactured by Banner Engineering Corp.