



MOC3051 / MOC3052



DESCRIPTION

The MOC3051 and MOC3052 are optically coupled isolators consisting of a Gallium Arsenide infrared emitting diode coupled with a light activated silicon bilateral switch performing the functions of a triac.

These photocouplers provide random phase control of high current triacs or thyristors. The MOC3051 and MOC3052 feature greatly enhanced static dv/dt capability to ensure stable switching performance of inductive loads.

These devices are mounted in a standard 6 pin dual-in-line package.

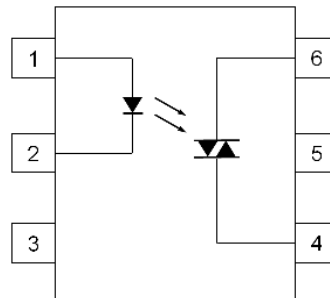

- 1 Anode
- 2 Cathode
- 3 NC
- 4 Main Terminal
- 5 Substrate (Do not Connect)
- 6 Main Terminal

FEATURES

- High Repetitive Peak Off-state Voltage V_{DRM} : minimum 600V
- High Critical Rate of Rise of Off-state Voltage dv/dt : minimum 1000V/ μ s)
- High Isolation Voltage between Input and Output V_{iso} : 5000Vrms
- Lead Free and RoHS Compliant
- UL File No. E91231
- VDE File No. 40028086

APPLICATIONS

- Solenoid / Valve Controls
- Lamp Ballasts
- Static AC Power Switch
- Interfacing Microprocessors to 115 and 240Vac Peripherals
- Solid State Relays
- Incandescent Lamp Dimmers
- Temperature Controls
- Motor Controls

ORDER INFORMATION

- Add Suffix "X" for VDE Approval
- Add G after PN for 10mm lead spacing
- Add SM after PN for Surface Mount
- Add SMT&R after PN for Surface Mount Tape & Reel

ABSOLUTE MAXIMUM RATINGS ($T_A = 25^\circ\text{C}$)

Stresses exceeding the absolute maximum ratings can cause permanent damage to the device. Exposure to absolute maximum ratings for long periods of time can adversely affect reliability.

Input

Forward Current	50mA
Reverse Voltage	6V
Power dissipation	100mW

Output

Peak Repetitive Surge Current (Pulse width = 1ms, 120pps)	1A
Off State Output Terminal Voltage	600V
Power Dissipation	300mW

Total Package

Isolation Voltage	5000V _{RMS}
Total Power Dissipation	330mW
Operating Temperature	-40 to 100 °C
Storage Temperature	-55 to 150 °C
Lead Soldering Temperature (10s)	260°C

ISOCOM COMPONENTS 2004 LTD

Unit 25B, Park View Road West, Park View Industrial Estate
Hartlepool, Cleveland, TS25 1PE, United Kingdom
Tel : +44 (0)1429 863 609 Fax : +44 (0)1429 863 581
e-mail : sales@isocom.co.uk
<http://www.isocom.com>

ISOCOM COMPONENTS ASIA LTD

Hong Kong Office,
Block A, 8/F, Wah Hing Industrial mansion,
36 Tai Yau Street, San Po Kong, Kowloon, Hong Kong.
Tel : +852 2995 9217 Fax : +852 8161 6292
e-mail : sales@isocom.com.hk



MOC3051 / MOC3052

ELECTRICAL CHARACTERISTICS ($T_A = 25^\circ\text{C}$ unless otherwise specified)

INPUT

Parameter	Symbol	Test Condition	Min	Typ.	Max	Unit
Forward Voltage	V_F	$I_F = 20\text{mA}$		1.2	1.5	V
Reverse Current	I_R	$V_R = 6\text{V}$		0.05	10	μA

OUTPUT

Parameter	Symbol	Test Condition	Min	Typ.	Max	Unit
Peak Off-state Current Either Direction	I_{DRM}	$V_{\text{DRM}} = 600\text{V}$ $I_F = 0\text{mA}$ Note 1			100	nA
On-State Voltage Either Direction	V_{TM}	$I_{\text{TM}} = 100\text{mA (peak)}$			3.0	V
Critical Rate of Rise of Off-State Voltage	dv/dt	$I_F = 0\text{mA}$	1000			V/ μs

COUPLED

Parameter	Symbol	Test Condition	Min	Typ.	Max	Unit
Input Trigger Current Either Direction	I_{FT}	$V_{\text{TM}} = 3\text{V}$ Note 2 MOC3051 MOC3052			15 10	mA
Holding Current Either Direction	I_{H}			200		μA

ISOLATION

Parameter	Symbol	Test Condition	Min	Typ.	Max	Unit
Insulation Voltage	V_{ISO}	AC 1 minute, RH 40 to 60% Note 3	5000			V_{RMS}

Note 1 : Test Voltage must be applied within static dv/dt rating.

Note 2 : Guaranteed to trigger at an I_F value less than or equal to max I_{FT} ,
recommended I_F lies between Rated I_{FT} to Absolute Max I_F .

Note 3 : Measured with input leads shorted together and output leads shorted together.

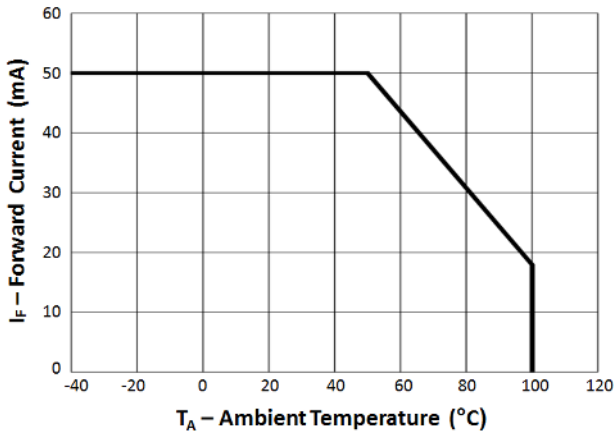

Fig 1 Forward Current vs Ambient Temperature

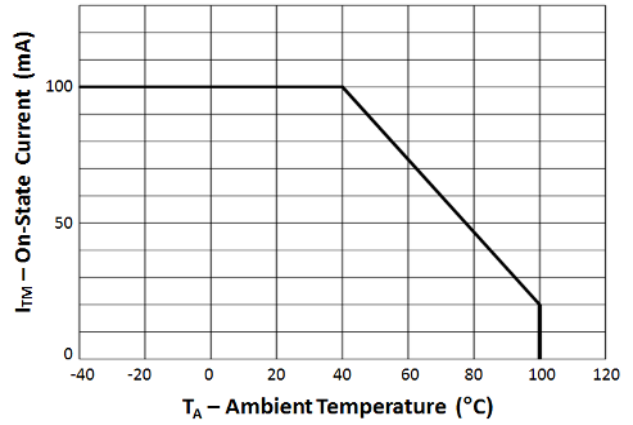

Fig 2 On-State Current vs Ambient Temperature

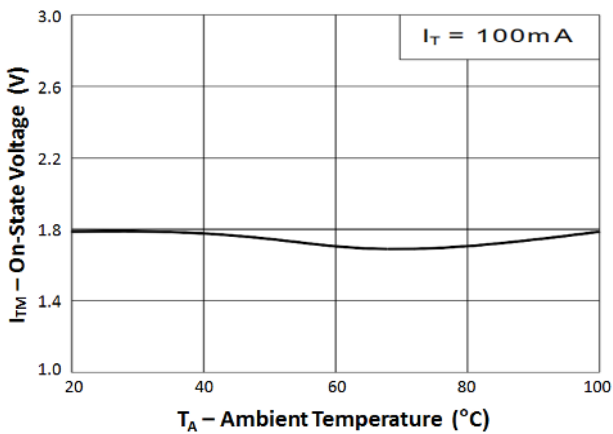

Fig 3 On-State Voltage vs Ambient Temperature

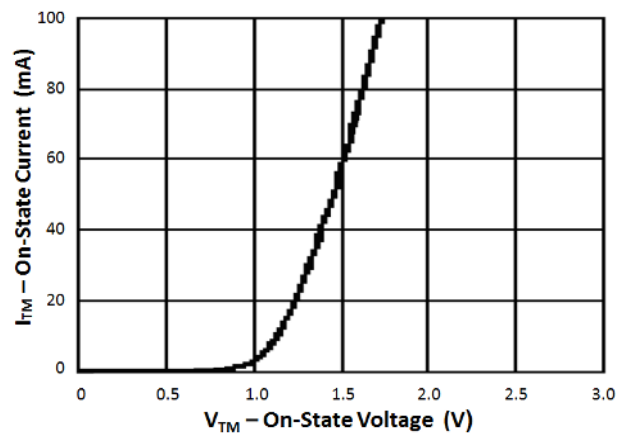

Fig 4 On-State Current vs On-State Voltage

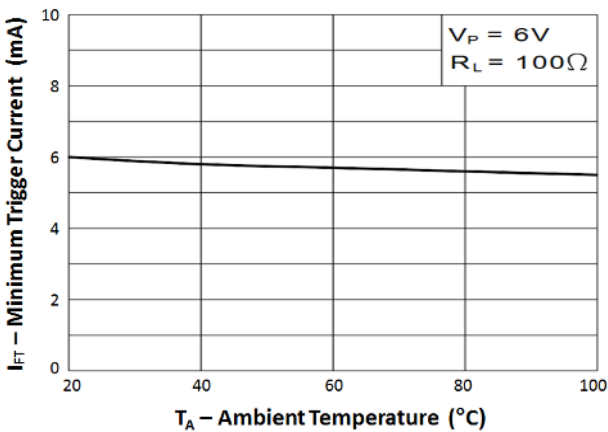

Fig 5 Minimum Trigger Current vs Ambient Temperature

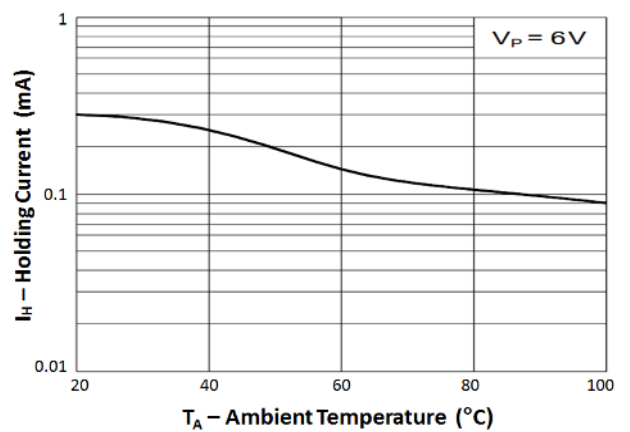

Fig 6 Holding Current vs Ambient Temperature

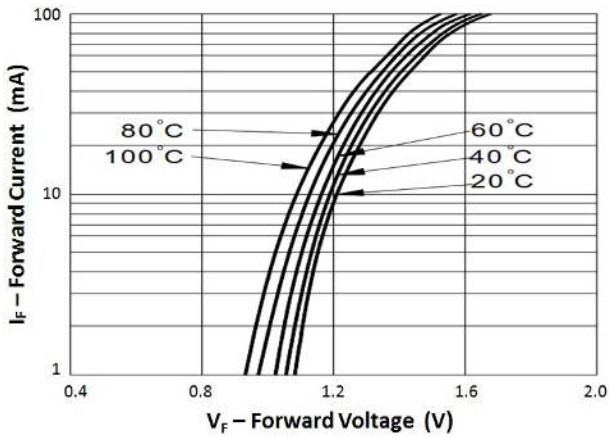

Fig 7 Forward Current vs Forward Voltage

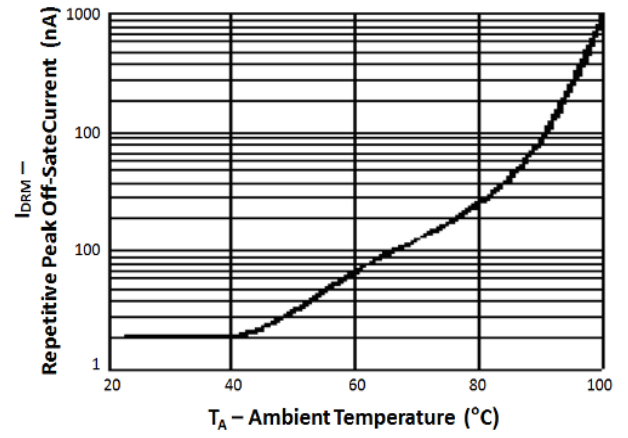

Fig 8 Repetitive Peak Off-State Current vs Ambient Temperature



MOC3051 / MOC3052

ORDER INFORMATION

MOC3051 / MOC3052 (UL Approval)			
After PN	PN	Description	Packing quantity
None	MOC3051, MOC3052	Standard DIP6	65 pcs per tube
G	MOC3051G, MOC3052G	10mm Lead Spacing	65 pcs per tube
SM	MOC3051SM, MOC3052SM	Surface Mount	65 pcs per tube
SMT&R	MOC3051SMT&R, MOC3052SMT&R	Surface Mount Tape & Reel	1000 pcs per reel

MOC3051X / MOC3052X (UL Approval and VDE Approvals)			
After PN	PN	Description	Packing quantity
None	MOC3051X, MOC3052X	Standard DIP6	65 pcs per tube
G	MOC3051XG, MOC3052XG	10mm Lead Spacing	65 pcs per tube
SM	MOC3051XSM, MOC3052XSM	Surface Mount	65 pcs per tube
SMT&R	MOC3051XSMT&R, MOC3052XSMT&R	Surface Mount Tape & Reel	1000 pcs per reel

DEVICE MARKING

Example : MOC3052

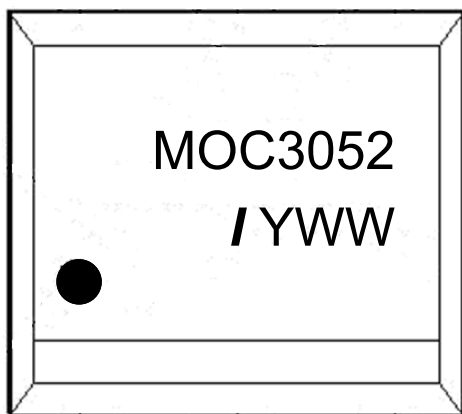

MOC3052 denotes Device Part Number

/ denotes Isocom

Y denotes 1 digit Year code

WW denotes 2 digit Week code



MOC3051 / MOC3052

PACKAGE DIMENSIONS in mm (inch)

DIP

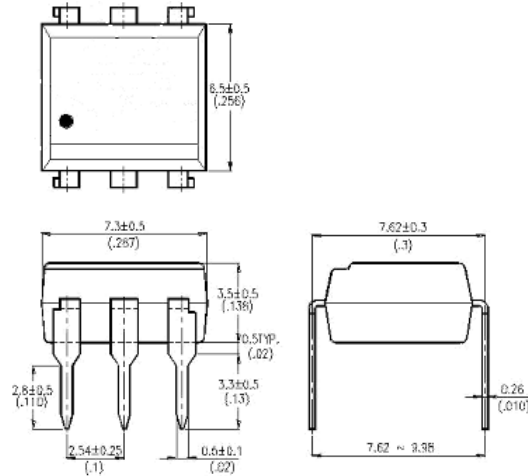

G Form

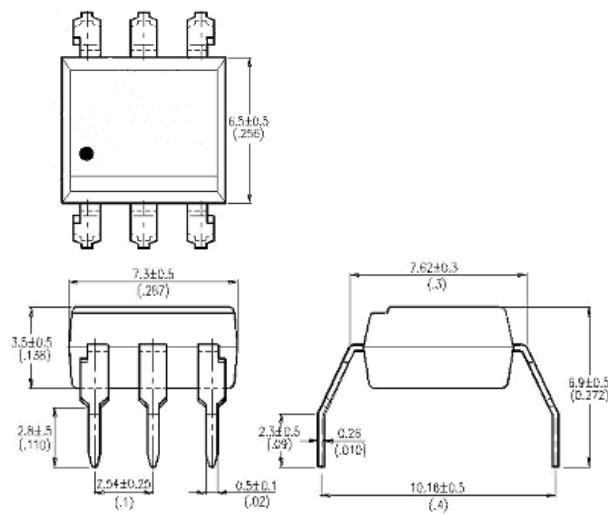

SMD

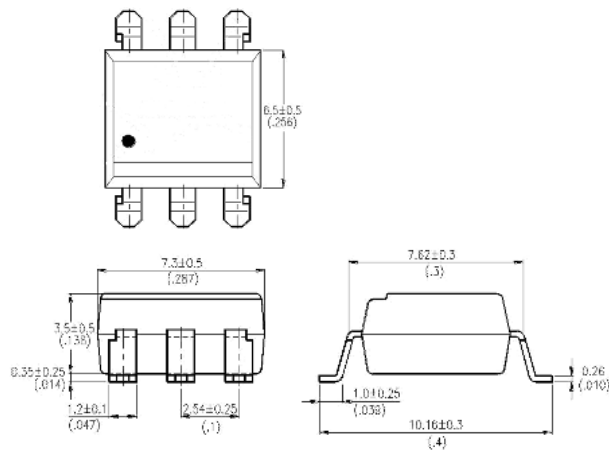



MOC3051 / MOC3052

RECOMMENDED PAD LAYOUT FOR SMD (mm)

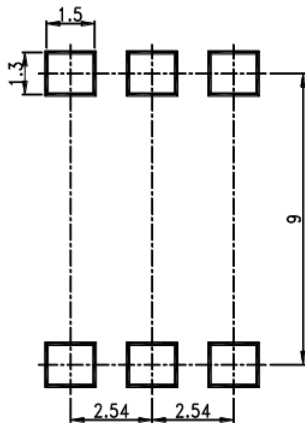

TAPE AND REEL PACKAGING

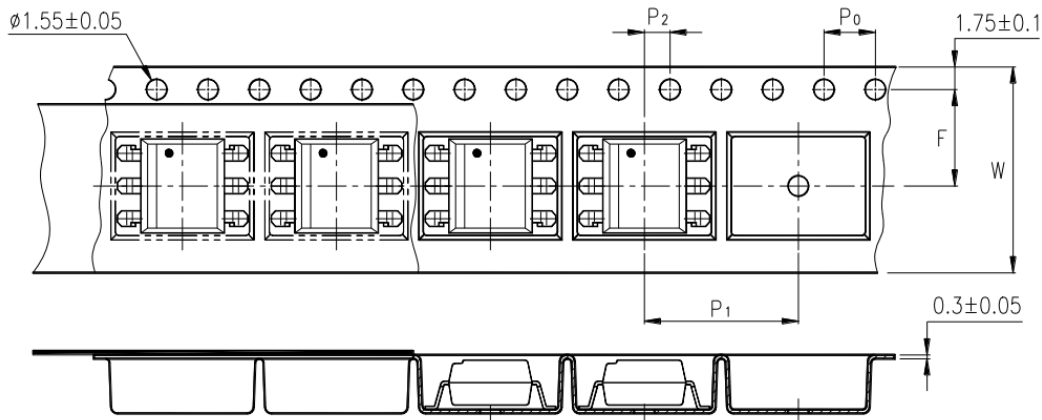

Description	Symbol	Dimension mm (inch)
Tape Width	W	16 ± 0.3 (0.63)
Pitch of Sprocket Holes	P ₀	4 ± 0.1 (0.15)
Distance of Compartment to Sprocket Holes	F	7.5 ± 0.1 (0.295)
	P ₂	2 ± 0.1 (0.079)
Distance of Compartment to Compartment	P ₁	12 ± 0.1 (0.472)



IR REFLOW SOLDERING TEMPERATURE PROFILE

Note : One Time Reflow Soldering is Recommended.
Do Not Immerse Device Body in Solder Paste.

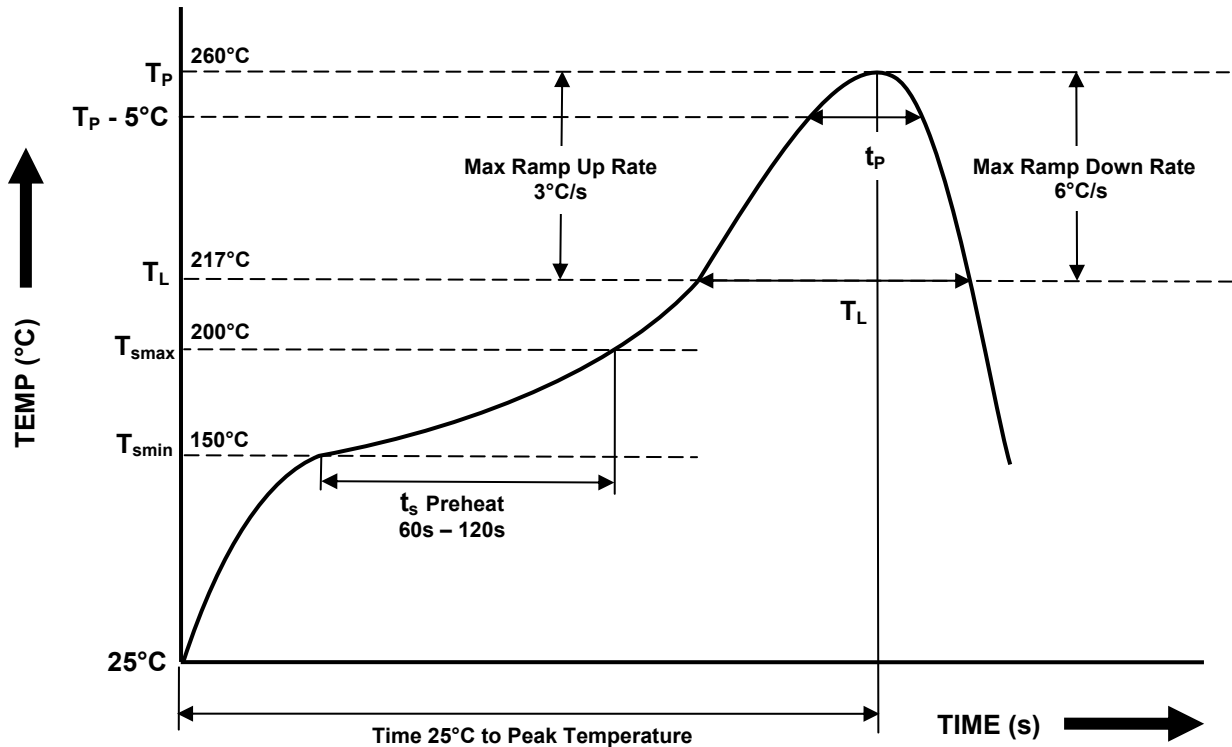

Profile Details	Conditions
Preheat - Min Temperature (T _{SMIN}) - Max Temperature (T _{SMAX}) - Time T _{SMIN} to T _{SMAX} (t _s)	150°C 200°C 60s - 120s
Soldering Zone - Peak Temperature (T _P) - Time at Peak Temperature - Liquidous Temperature (T _L) - Time within 5°C of Actual Peak Temperature (T _P - 5°C) - Time maintained above T _L (t _L) - Ramp Up Rate (T _L to T _P) - Ramp Down Rate (T _P to T _L)	260°C 10s max 217°C 30s max 60s - 100s 3°C/s max 6°C/s max
Average Ramp Up Rate (T _{Smax} to T _P)	3°C/s max
Time 25°C to Peak Temperature	8 minutes max



DISCLAIMER

Isocom Components is continually working to improve the quality and reliability of its products. Nevertheless, semiconductor devices in general can malfunction or fail due to their inherent electrical sensitivity and vulnerability to physical stress. It is the responsibility of the buyer, when utilizing Isocom Components products, to comply with the standards of safety in making a safe design for the entire system, and to avoid situations in which a malfunction or failure of such Isocom Components products could cause loss of human life, bodily injury or damage to property.

In developing your designs, please ensure that Isocom Components products are used within specified operating ranges as set forth in the most recent Isocom Components products specifications.

The Isocom Components products listed in this document are intended for usage in general electronics applications (computer, personal equipment, office equipment, measuring equipment, industrial robotics, domestic appliances, etc.). These Isocom Components products are neither intended nor warranted for usage in equipment that requires extraordinarily high quality and/or reliability or a malfunction or failure of which may cause loss of human life or bodily injury ("Unintended Usage"). Unintended Usage include atomic energy control instruments, airplane or spaceship instruments, transportation Instruments, traffic signal instruments, combustion control instruments, medical Instruments, all types of safety devices, etc... Unintended Usage of Isocom Components products listed in this document shall be made at the customer's own risk.

Gallium arsenide (GaAs) is a substance used in the products described in this document. GaAs dust and fumes are toxic. Do not break, cut or pulverize the product, or use chemicals to dissolve them. When disposing of the products, follow the appropriate regulations. Do not dispose of the products with other industrial waste or with domestic garbage.

The products described in this document are subject to the foreign exchange and foreign trade laws.

The information contained herein is presented only as a guide for the applications of our products. No responsibility is assumed by Isocom Components for any infringements of intellectual property or other rights of the third parties which may result from its use. No license is granted by implication or otherwise under any intellectual property or other rights of Isocom Components or others.

The information contained herein is subject to change without notice.