

# ZXFV201, ZXFV203

## QUAD AND TRIPLE VIDEO AMPLIFIER

### Device description

The ZXFV201/203 are quad and triple, high speed amplifiers designed for video and other high speed applications.

They feature low differential gain and phase performance. Together with high output drive and slew rate capability, this brings high performance to video applications.

The ZXFV203 is ideal for RGB buffer applications, with the ZXFV201 ideal for RGSB applications.

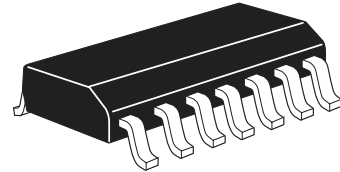

### Features and benefits

- Unity gain bandwidth 300MHz
- Slew rate 400V/ $\mu$ s
- Differential gain 0.01%
- Differential phase 0.01°
- Output current 40mA
- Characterized up to 300pF load
- $\pm$ 5 Volt supply
- Supply current 7mA per amplifier
- 14 pin SO package

### Applications

- Video gain stages
- CCTV buffer
- Video distribution
- RGB buffering
- Home theatre
- Fast ADC signal input drive
- Cable driving

### Ordering Information

Part number	Container	Increment
ZXFV201N14TA	reel 7"	500
ZXFV201N14TC	reel 13"	2500
ZXFV203N14TA	reel 7"	500

Connection diagram

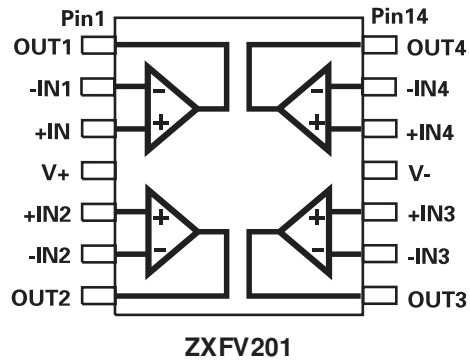

Connection diagram

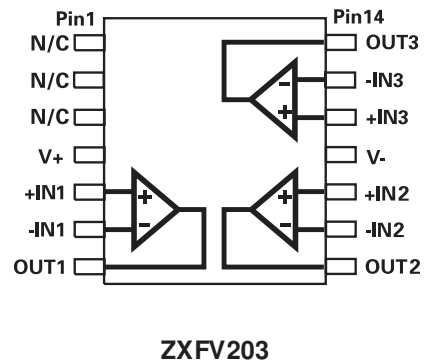

# ZXFV201, ZXFV203

## ABSOLUTE MAXIMUM RATINGS Over Operating Free-Air Temperature (Unless Otherwise Stated)<sup>(1)</sup>

Supply voltage, V+ to V-	-0.5V to +11V
Input voltage (V <sub>-IN</sub> , V <sub>+IN</sub> )*	V <sub>-</sub> -0.5V to V <sub>+</sub> +0.5V
Differential input voltage, VID	±3V
Inverting input current (I-IN) <sup>(2)</sup>	±5 mA
Output current, (continuous, T <sub>J</sub> < 110°C)	±60 mA
Internal power dissipation	See power dissipation derating table
Operating free air temperature range, T <sub>A</sub>	-40 to 85°C
Storage temperature range	-65°C to +150°C
Operating ambient junction temperature T <sub>JMAX</sub>	150°C

### Notes:

- (1) Stresses above those listed under Absolute Maximum Ratings may cause permanent damage to the device. This is a stress rating only; functional operation of the device at these or any other conditions above those indicated in the operational section of this specification is not implied. Exposure to absolute maximum rating conditions for extended periods may affect device reliability.
- (2) At high closed loop gains and low gain setting resistors care must be taken if large input signals are applied to the device which cause the output stage to saturate for extended periods of time.
- (3) The power dissipation of the device when loaded must be designed to keep the device junction temperature below T<sub>JMAX</sub>.

Package	Theta-ja	Power rating at 25°C
SO14	120°C/W	1.04W

\* During power-up and power-down, these voltage ratings require that signals be applied only when the power supply is connected.

ESD: This device is sensitive to static discharge and proper handling precautions are required.

## ELECTRICAL CHARACTERISTICS

±5V power supplies, T<sub>amb</sub> = 25°C unless otherwise stated. R<sub>f</sub> = 1kΩ, R<sub>L</sub> = 150Ω, C<sub>L</sub> ≤ 10pF

PARAMETER	CONDITIONS	TEST	MIN	TYP	MAX	UNIT
Supply voltage V+ operating range			4.75	5	5.25	V
Supply voltage V- operating range			-5.25	-5	-4.75	V
Supply current/per channel		P	5.0	7.5	10	mA
Input common mode voltage range		P		±3		V
Input offset voltage		P		1	10	mV
Output offset voltage		P		2	20	mV
Input bias current, non-inverting input		P		5	10	μA
Input resistance		P	1.5	2	6.5	MΩ
Output voltage swing	I <sub>OUT</sub> = 40mA	P		±3		V
Output drive current	V <sub>IN</sub> = 3V	P	40			mA
Positive PSRR	ΔV <sub>+</sub> = ±0.25	P	49	57		dB
Negative PSRR	ΔV <sub>-</sub> = ±0.25	P	49	57		dB
Bandwidth -3dB	A <sub>v</sub> = +1, V <sub>out</sub> = 200mV pk-pk	C		300		MHz
Bandwidth -0.1dB	A <sub>v</sub> = +1, V <sub>out</sub> = 200mV pk-pk	C		30		MHz
Slew rate	A <sub>v</sub> = +1 A <sub>v</sub> = +2 A <sub>v</sub> = +10	C		400 400 400		V/μs
Rise time	V <sub>OUT</sub> = ±1 V, 10% - 90%	C		4.0		ns
Fall time	V <sub>OUT</sub> = ±1 V, 10% - 90%	C		3.2		ns
Propagation delay	V <sub>OUT</sub> = ±2 V, 50%	C		4.0		ns
Differential gain	3.58MHz (NTSC) and 4.43MHz (PAL) DC = -714 to +714 mV, 280mVpp	C		0.02		%
Differential phase		C		0.02		deg

Test – P = production tested. C = characterised



ISSUE 3 - DECEMBER 2003

# ZXFV201, ZXFV203

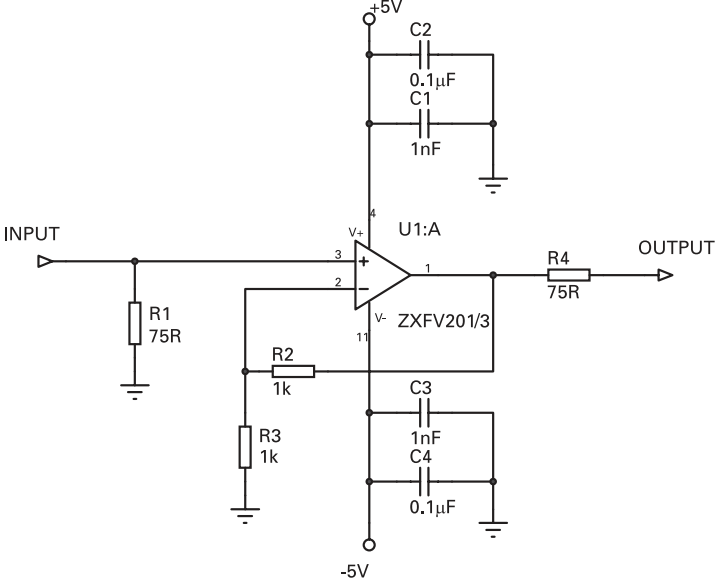

Figure 1: Typical video signal application circuit, gain = 2 (overall gain = 1 for 75Ω load)

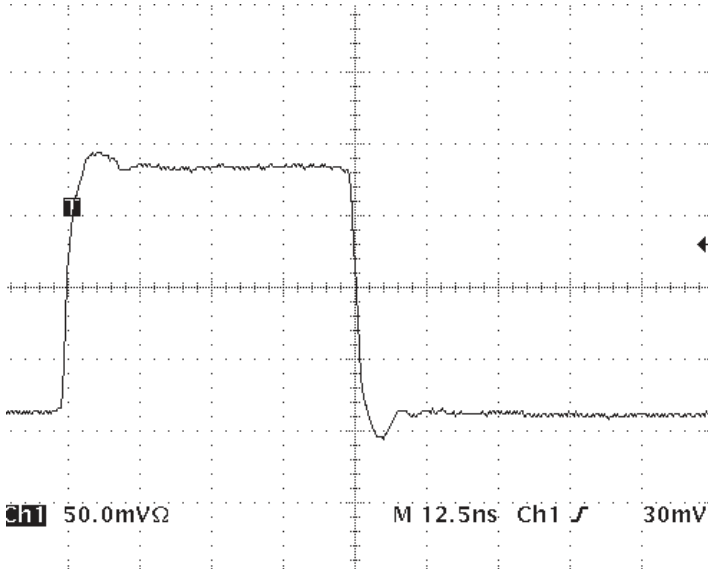

Figure 2: Pulse response, unity gain, 1V pk-pk,  $R_F = 510\Omega$

# ZXFV201, ZXFV203

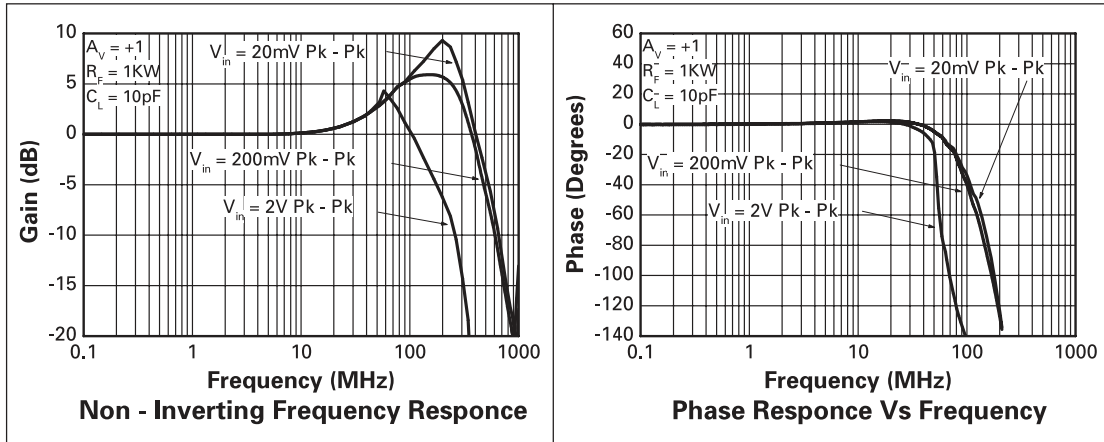

Figure 3: Graphs of gain and phase vs frequency ( $R_L=150\Omega$ )

## APPLICATIONS INFORMATION

### Introduction

A typical circuit application is shown in Figure 1, above. This is suitable for  $75\Omega$  transmission line connections at both the input and the output and is useful for distribution of wide-band signals such as video via cables. The  $75\Omega$  reverse terminating resistor R4 gives the correct matching condition to a terminated video cable. The amplifier load is then  $150\Omega$  in parallel with the local feedback network.

The wide bandwidth of this device necessitates some care in the layout of the printed circuit. A continuous ground plane is required under the device and its signal connection paths, to provide the shortest possible ground return paths for signals and power supply filtering. A double-sided or multi-layer PCB construction is required, with plated-through via holes providing closely spaced low-inductance connections from some components to the continuous ground plane.

For the power supply filtering, low inductance surface mount capacitors are normally required. It has been found that very good RF decoupling is provided on each supply using a  $1000\text{pF}$  NPO size 0805 or smaller ceramic surface mount capacitor, closest to the device pin, with an adjacent  $0.1\mu\text{F}$  X7R capacitor. Other configurations are possible and it may be found that a single  $0.01\mu\text{F}$  X7R capacitor on each supply gives good results. However this should be supported by larger decoupling capacitors elsewhere on the printed circuit board. Values of 1 to  $10\mu\text{F}$  are recommended, particularly where the voltage regulators are located more than a few inches from the device. These larger capacitors are recommended to be solid tantalum electrolytic or ceramic types.

Note particularly that the inverting input of this current feedback type of amplifier is sensitive to small amounts of capacitance to ground which occur as part of the practical circuit board layout. This capacitance affects bandwidth, frequency response peaking and pulse overshoot. Therefore to minimise this capacitance, the feedback components R2 and R3 of Figure 1 should be positioned as close as possible to the inverting input connection.

The frequency response and pulse response will vary according to particular values of resistors and layout capacitance. The response can be tailored for the application to some extent by choice of the value of feedback resistor. Figure 2 shows an oscilloscope display of the pulse response for a practical double sided printed circuit board where  $R_F = 510\Omega$ .

# ZXFV201, ZXFV203

Notes



# ZXFV201, ZXFV203

Notes

# ZXFV201, ZXFV203

Notes



# ZXFV201, ZXFV203

## PACKAGE OUTLINE

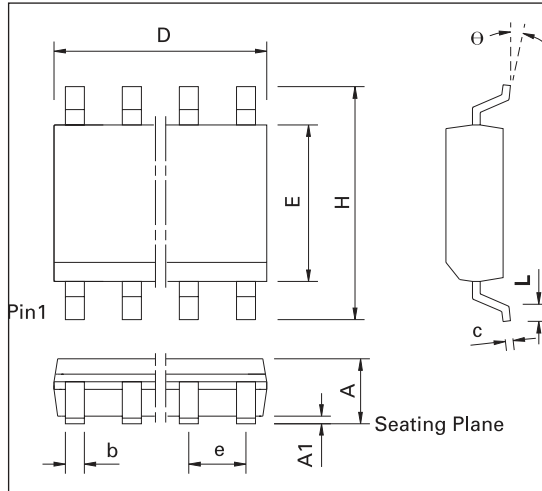

## PACKAGE DIMENSIONS

DIM	Millimeters		Inches		DIM	Millimeters		Inches	
	Min	Max	Min	Max		Min	Max	Min	Max
A	1.35	1.75	0.053	0.069	E	3.80	4.00	0.15	0.157
A1	0.10	0.25	0.004	0.01	H	5.80	6.20	0.228	0.244
b	0.33	0.51	0.013	0.020	L	0.40	1.27	0.016	0.05
c	0.19	0.25	0.008	0.010	θ	0°	8°	0°	8°
D	8.55	8.75	0.337	0.344	-	-	-	-	-
e	1.27 BSC		0.05 BSC		-	-	-	-	-

© Zetex plc 2003

Europe	Americas	Asia Pacific	Corporate Headquarters
Zetex GmbH Streitfeldstraße 19 D-81673 München Germany	Zetex Inc 700 Veterans Memorial Hwy Hauppauge, NY 11788 USA	Zetex (Asia) Ltd 3701-04 Metroplaza Tower 1 Hing Fong Road, Kwai Fong Hong Kong	Zetex plc Fields New Road, Chadderton Oldham, OL9 8NP United Kingdom
Telefon: (49) 89 45 49 49 0 Fax: (49) 89 45 49 49 49 europe.sales@zetex.com	Telephone: (1) 631 360 2222 Fax: (1) 631 360 8222 usa.sales@zetex.com	Telephone: (852) 26100 611 Fax: (852) 24250 494 asia.sales@zetex.com	Telephone (44) 161 622 4444 Fax: (44) 161 622 4446 hq@zetex.com

These offices are supported by agents and distributors in major countries world-wide.

This publication is issued to provide outline information only which (unless agreed by the Company in writing) may not be used, applied or reproduced for any purpose or form part of any order or contract or be regarded as a representation relating to the products or services concerned. The Company reserves the right to alter without notice the specification, design, price or conditions of supply of any product or service.

For the latest product information, log on to [www.zetex.com](http://www.zetex.com)



ISSUE 3 - DECEMBER 2003