

THIS DRAWING IS UNPUBLISHED. RELEASED FOR PUBLICATION
 © COPYRIGHT - By - ALL RIGHTS RESERVED.

LOC	DIST	REVISIONS			
P	LTR	DESCRIPTION	DATE	DWN	APVD
AF	50	Y	REVISED PER ECR-13-004343	30JUL13	KH KR

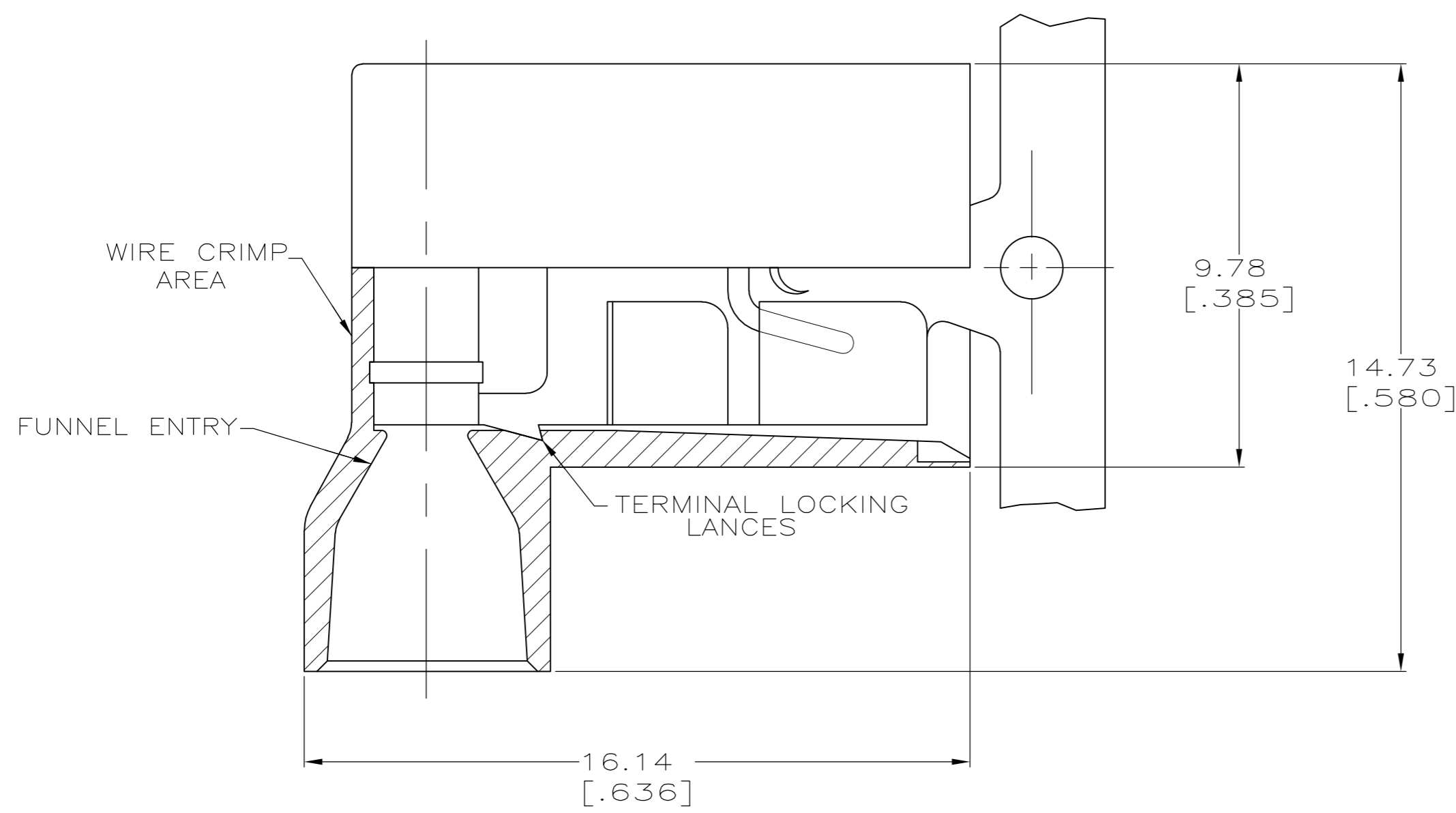

- 1 FITS 0.81±0.025 X 6.35 [.032±.001 X .250] TAB
- 2 WIRE SIZE: 0.3-0.9mm² [22-18 AWG], STRANDED ONLY. STRIP LENGTH 7.94 [.312]
- 3 INSULATION SIZE: 4.19 [.165] MAX DIA.
- 4 CONTINUOUS STRIP.

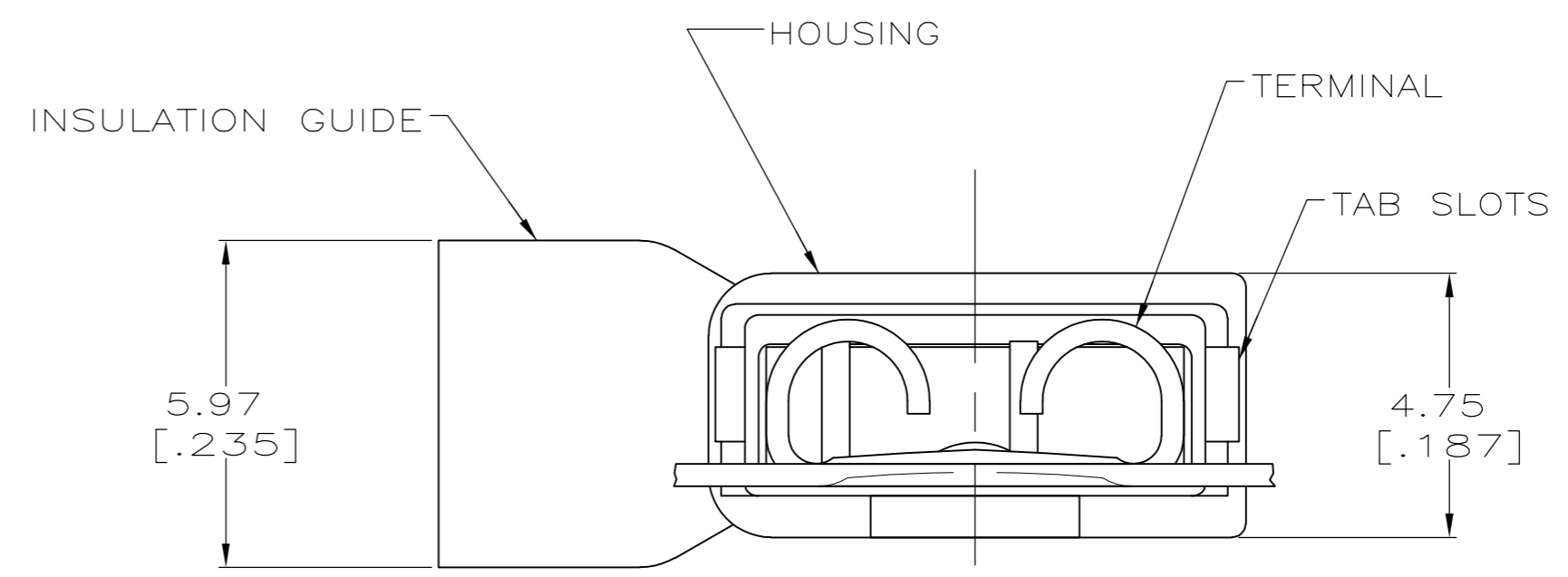
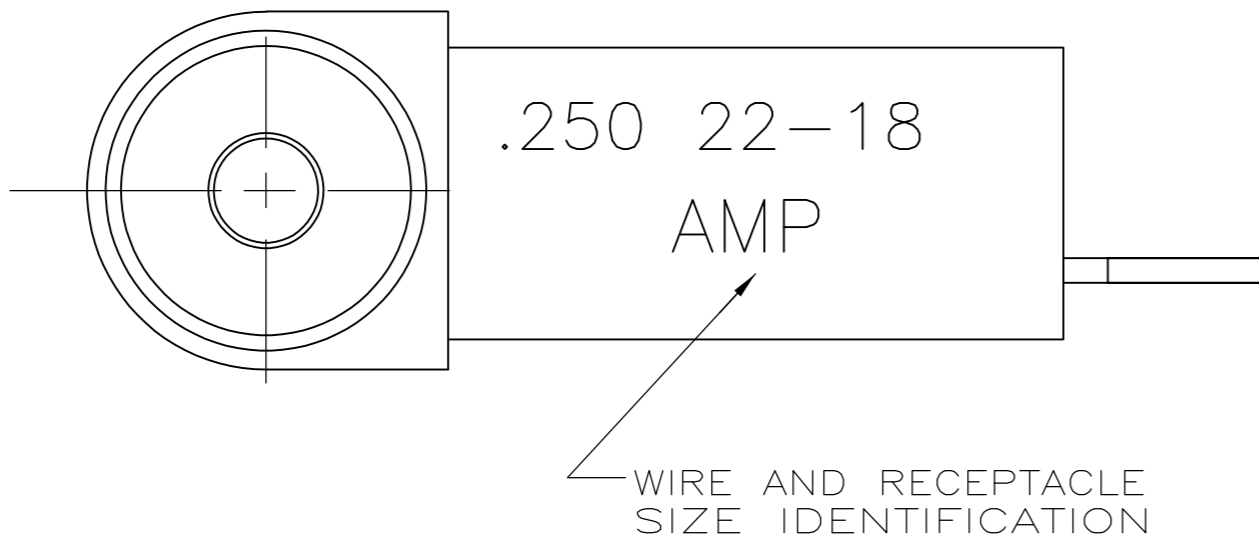

BULK	TYPE 6/6 NYLON	RED TRANSLUCENT	BRASS	TIN	5-520128-2
STANDARD					2-520128-2
PACKAGING	MATERIAL	COLOR	MATERIAL	FINISH	PART NO
	HOUSING		TERMINAL		

THIS DRAWING IS A CONTROLLED DOCUMENT.		DWN P FORTNEY 10/19/89	 RECEPTACLE ASSEMBLY, ULTRA-FAST FLAG, 6.35 [.250] SERIES		
DIMENSIONS: MM [INCHES]		CHK JR RUTH 10/19/89			
TOLERANCES UNLESS OTHERWISE SPECIFIED:		APVD D BRATINA 10/19/89			
0 PLC ± - 1 PLC ± - 2 PLC ± - 3 PLC ± 0.38 [.015] 4 PLC ± - ANGLES ± -		PRODUCT SPEC 108-2043			
MATERIAL SEE TABLE	FINISH SEE TABLE	APPLICATION SPEC 114-2123	SIZE A2	CAGE CODE 00779	DRAWING NO C=520128
CUSTOMER DRAWING			RESTRICTED TO -	SCALE 8:1	SHEET 1 of 1