

Figure 1

## 1. INTRODUCTION

11-Position Living-Hinge Connectors 1326359-1 and -2 accept USCAR-approved 2.8-mm Receptacle Contacts 1326030-1, -2, -3, and -4. The contacts must be terminated to wire size range of 0.35 to 4.0 mm<sup>2</sup> (US customary wire size range of 22 to 12 AWG). The connectors do not accept contacts terminated to wire size 10 AWG. This instruction sheet provides contact insertion and extraction procedures.

### NOTE

All numerical values are in metric units. Figures are not drawn to scale.

Reasons for reissue of this instruction sheet are provided in Section 5, REVISION SUMMARY.

## 2. DESCRIPTION

Each connector consists of a housing with contact cavities, a hinged rear-lock, and locking latches that secure mating connectors together. Each contact cavity features a primary locking latch.

Each contact has an orientation feature that prevents the contact from being inserted into the contact cavity incorrectly. When the contact is fully inserted, it snaps into position behind the primary locking latch (retention finger).

After all contacts are fully inserted into the connector, they are further secured by the hinged rear-lock (a secondary lock), which also detects contacts that have not been fully seated.

## 3. INSERTION PROCEDURE

### NOTE



The following procedure assumes that the contacts have been properly terminated. Refer to Application Specification 114-13013 for crimp requirements. For information on terminating contacts, refer to the instructions packaged with the crimp tooling.

1. Ensure that the hinged rear-lock of the connector is in the pre-lock (OPEN) position as shown in Figure 1. If it is not, refer to Figure 2, and proceed as follows:

a. Insert the tip of a standard 4-mm flat-blade screwdriver under one of the tabs (each marked with an arrow). Seat the screwdriver firmly against the side of the hinged rear-lock and rotate the screwdriver toward the mating face of the connector until the side of the hinged rear-lock lifts from the housing.

b. Repeat this step for the other tab.

c. Carefully open the hinged rear-lock until it is in the pre-lock position (OPEN).

### NOTE



The hinged rear-lock must be OPEN before inserting any contacts into the housing.

### Moving Hinged Rear-Lock to Pre-Lock (OPEN) Position

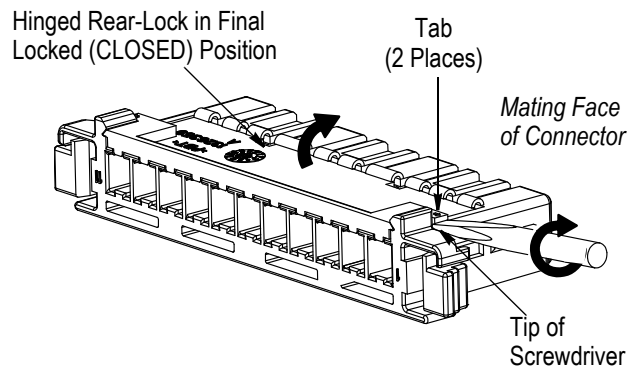

Figure 2

2. Align the crimped contact with the wire end of the housing so that the orientation features are pointing away from the hinged rear-lock. Insert the contact into the desired contact cavity until it stops. There will be an audible "click" when the contact is fully seated. See Figure 1.

3. Pull back *lightly* on the wire to ensure that the contact has been fully engaged in the contact cavity. See Figure 3.

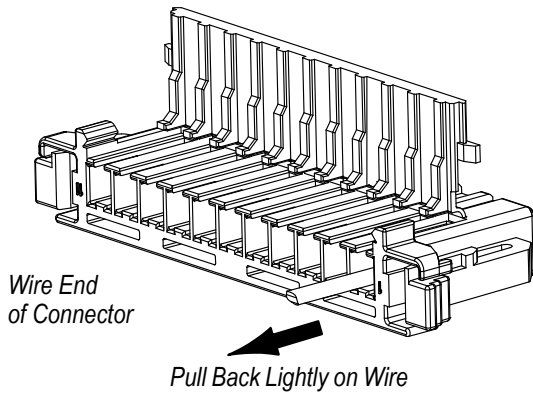

Figure 3

4. After all contacts have been inserted, rotate the hinged rear-lock; then, to close the hinged rear-lock, simultaneously press the two thumb pads (one with the right-hand thumb/finger and one with the left-hand thumb/finger) until the hinged rear-lock is seated in the final locked (CLOSED) position. Make sure both locking points have been seated. There will be audible feedback. See Figure 4.

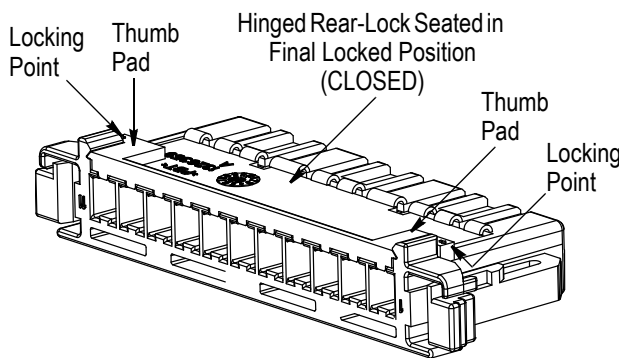

Figure 4

5. If the hinged rear-lock will not fully close, open the hinged rear-lock and ensure that all of the contacts are fully seated, then repeat Step 4. DO NOT force the hinged rear-lock to close.

**NOTE**



If the contact insulation barrel crimp does not protrude beyond the rear of the housing, the hinged rear-lock will detect a partially seated contact. If the insulation barrel crimp does protrude beyond the rear of the housing, the detection will not occur. Visually inspect the contacts and make sure that all contacts are fully inserted.

**4. EXTRACTION PROCEDURE**

1. Open the hinged rear-lock of the connector as described in Section 3, Step 1.
2. At the mating end of the connector, insert the tip of a 1.5-mm (or smaller) flat-blade screwdriver into the contact cavity of the contact to be removed. See Figure 5, Detail A.

3. Grasp the wire of the contact to be removed and push the contact forward into the contact cavity until it stops. See Figure 5, Detail A.

4. Using the screwdriver, gently deflect the retention finger of the contact cavity, and simultaneously pull the wire until the contact is free from the retention finger. See Figure 5, Detail B. Pull the contact from the housing. See Figure 5, Detail C.



DO NOT re-use or repair terminated contacts.

**Extracting Contact from Housing**

Detail A

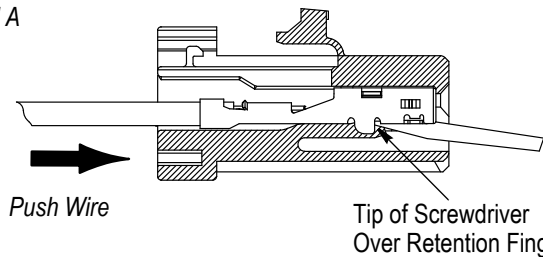

Detail B

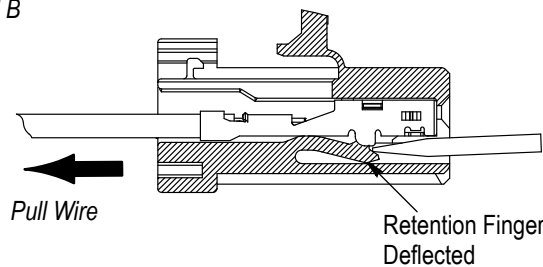

Detail C

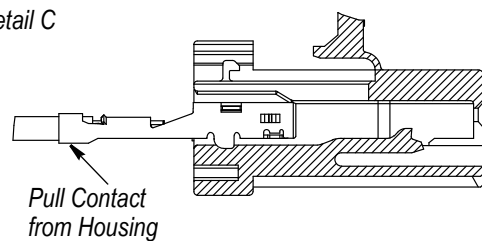

Figure 5

5. After all desired contacts have been extracted, close the hinged rear-lock as described in Section 3, Step 4.

**5. REVISION SUMMARY**

Revisions to this instruction sheet include:

- Updated instruction sheet to corporate requirements
- Removed USCAR and 2.8-mm from connector
- Modified arrangement of text
- Changed 4 to 2 locking points
- Added Step 5 to Section 4