

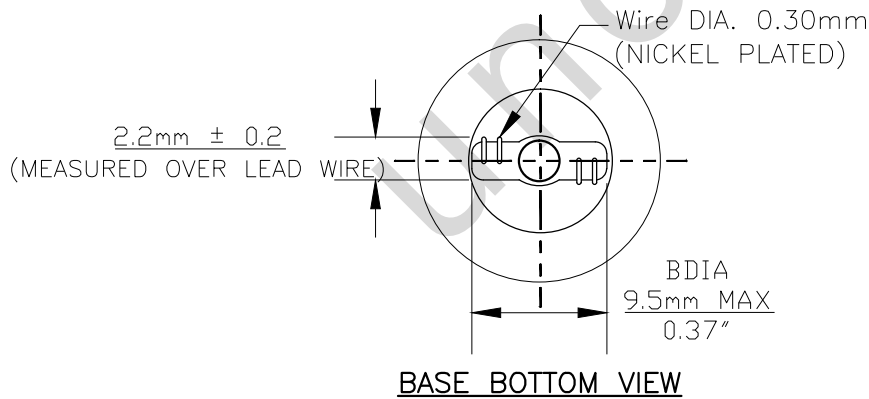

PART NO.	BASE TYPE	DESIGN VOLTS	DESIGN AMPS	MSCD	FILAMENT TYPE	AVERAGE LIFE HOURS	REVISIONS			
							REV #	DESCRIPTION	DATE	APPROVED
912NA	Glass Wedge W2.1X9.5d (T-5)	12.8V	1.0±10%	9.0±30%	C-2R	1000	1	ISSUED	06/26/2014	R.M.

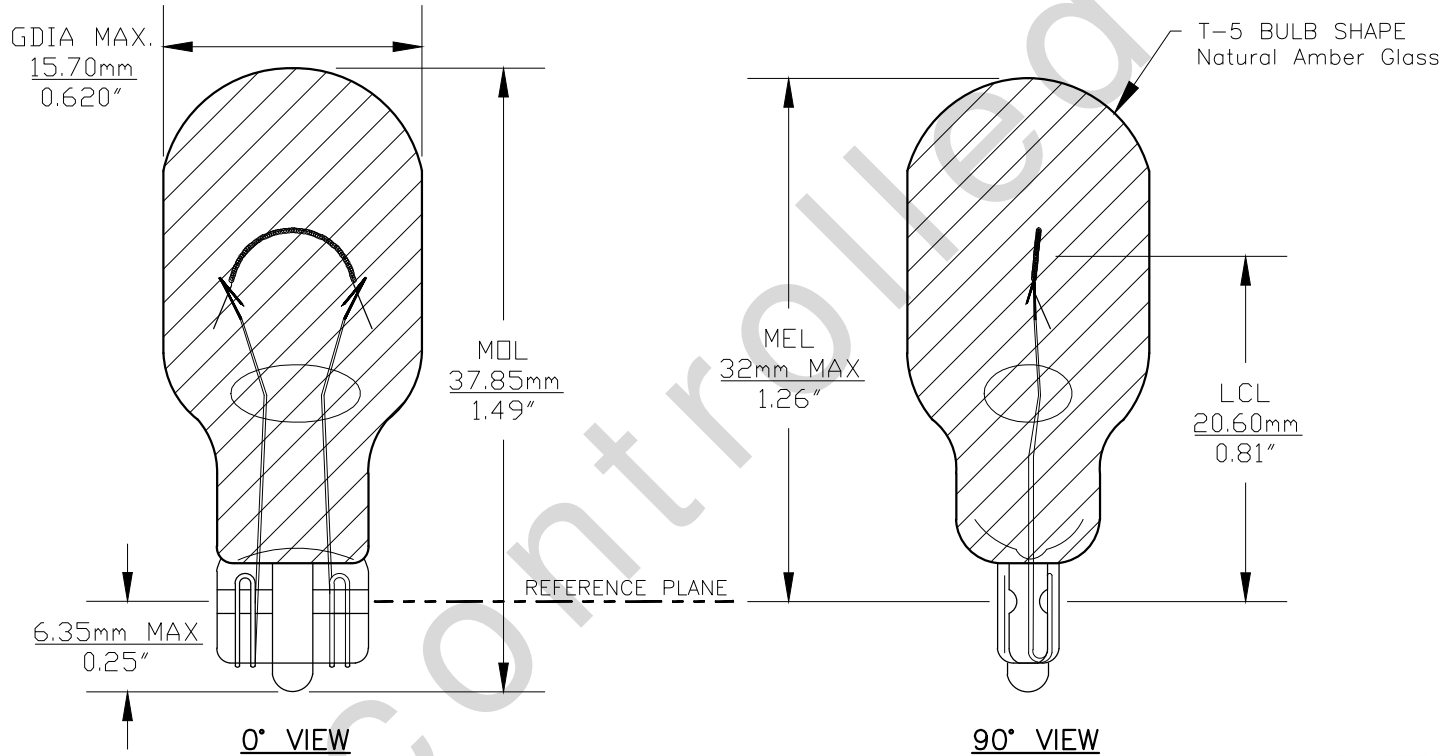

Note: Made according to SAE specifications



UNLESS OTHERWISE SPECIFIED: DIMENSIONS ARE IN INCHES TOLERANCES		CEC INDUSTRIES LTD			
DECIMALS	ANGULAR	599 BOND STREET		LINCOLNSHIRE, IL 60069	
.XX ± .05	± 0.5°	TITLE LIGHT BULB NO. 912NA			
.XXX ± .010		SIZE A	FSCM NO.	DWG NO. 912NA	REV 1
FRACTIONAL	± 1/64	DESIGN	SCALE	PLOT SCALE	SHEET 1 OF 1
DRAWN ROSE MEDINA DATE 06/26/2014		MATERIAL FILE 912NA.pdf DRAWING NOT TO SCALE			