

THIS DRAWING IS UNPUBLISHED. RELEASED FOR PUBLICATION  
 © COPYRIGHT - BY - ALL RIGHTS RESERVED.

REVISIONS				
P	LTR	DESCRIPTION	DATE	APVD
E		REV PER ECO 18-000314	1-9-18	CT DW

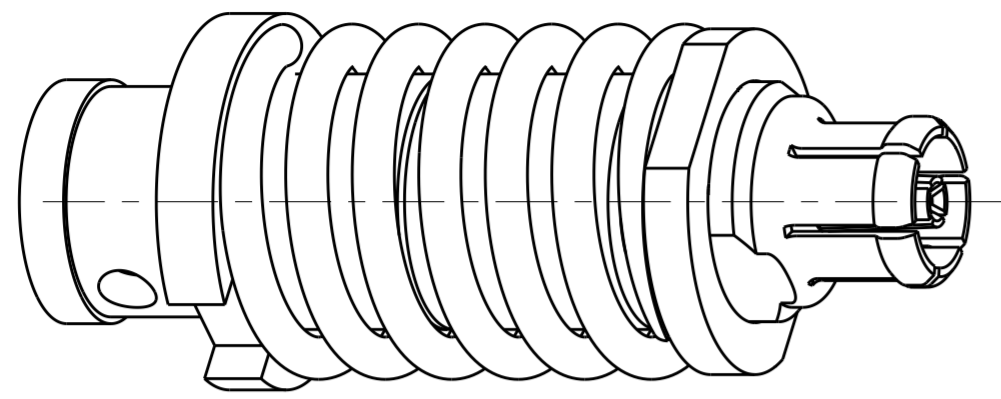

SCALE 10:1

1 MATERIAL:  
 BODY & CENTER CONTACT - BERYLIUM COPPER,  
 ALLOY UNS C17300 CONDITION TDO4, PER ASTM B196  
 INSULATOR - TEFLON (PTFE) ROD, PER ASTM D 1710  
 RETAINING RING - STAINLESS STEEL, PER UNS S30200  
 SPRING - MUSIC WIRE, PER ASTM A228

2 FINISH:  
 BODY & CENTER CONTACT - GOLD PLATE, PER ASTM B488  
 OVER NICKEL PLATE PER SAE-ASM-QQ-N-290  
 RETAINING RING - PASSIVATED  
 SPRING - NICKEL PLATE, PER SAE-ASM-QQ-N-290

3. SPRING FORCE:  
 PRELOAD = 2.35 ±.25 LBF  
 FORCE AT .052 DEFLECTION = 3.60±.25 LBF  
 MINIMUM FULL DEFLECTION = .078 [2.0]

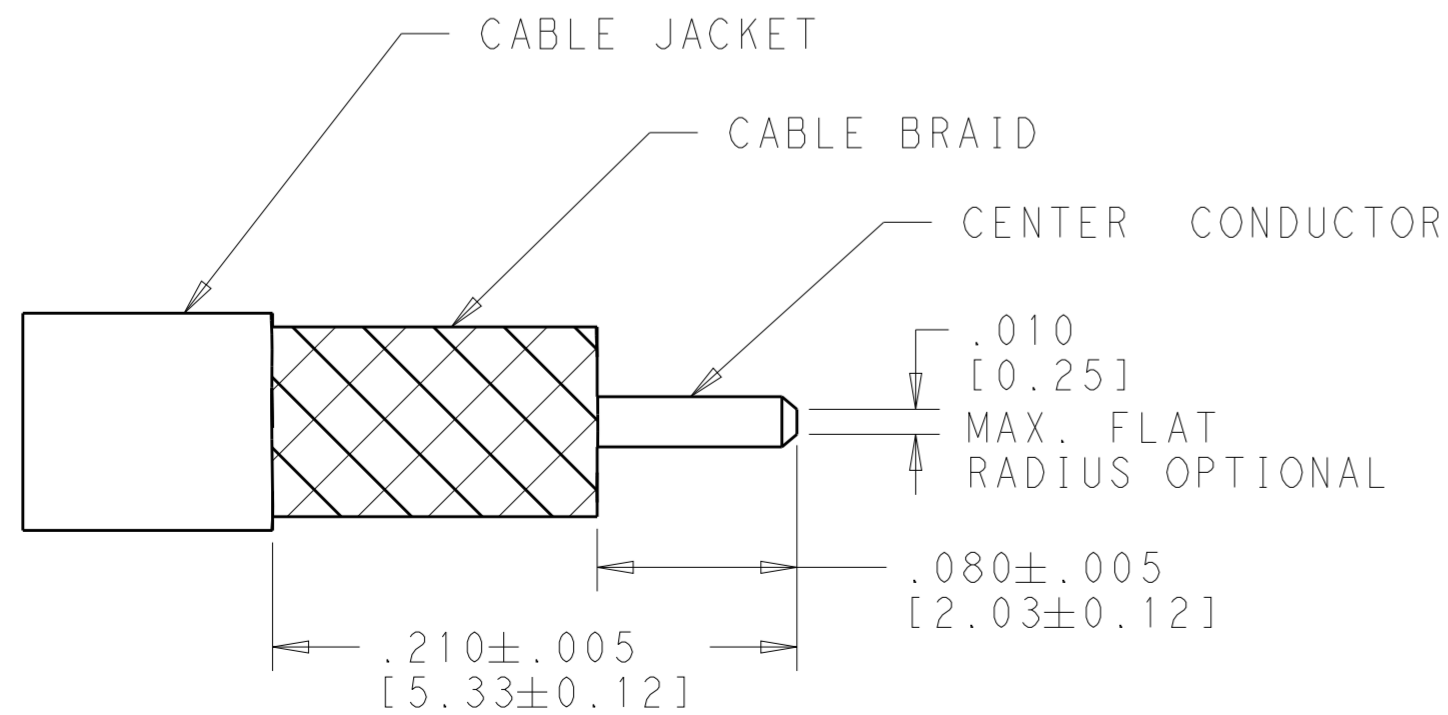
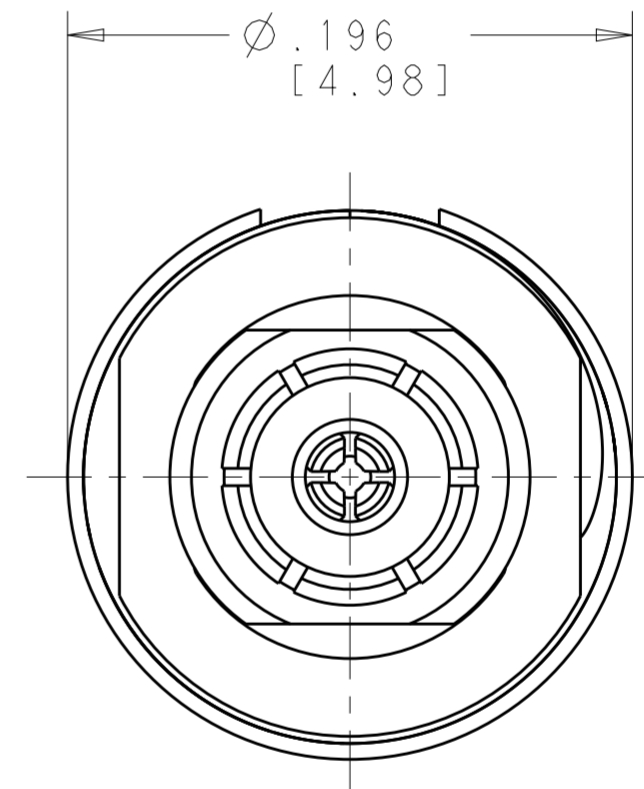
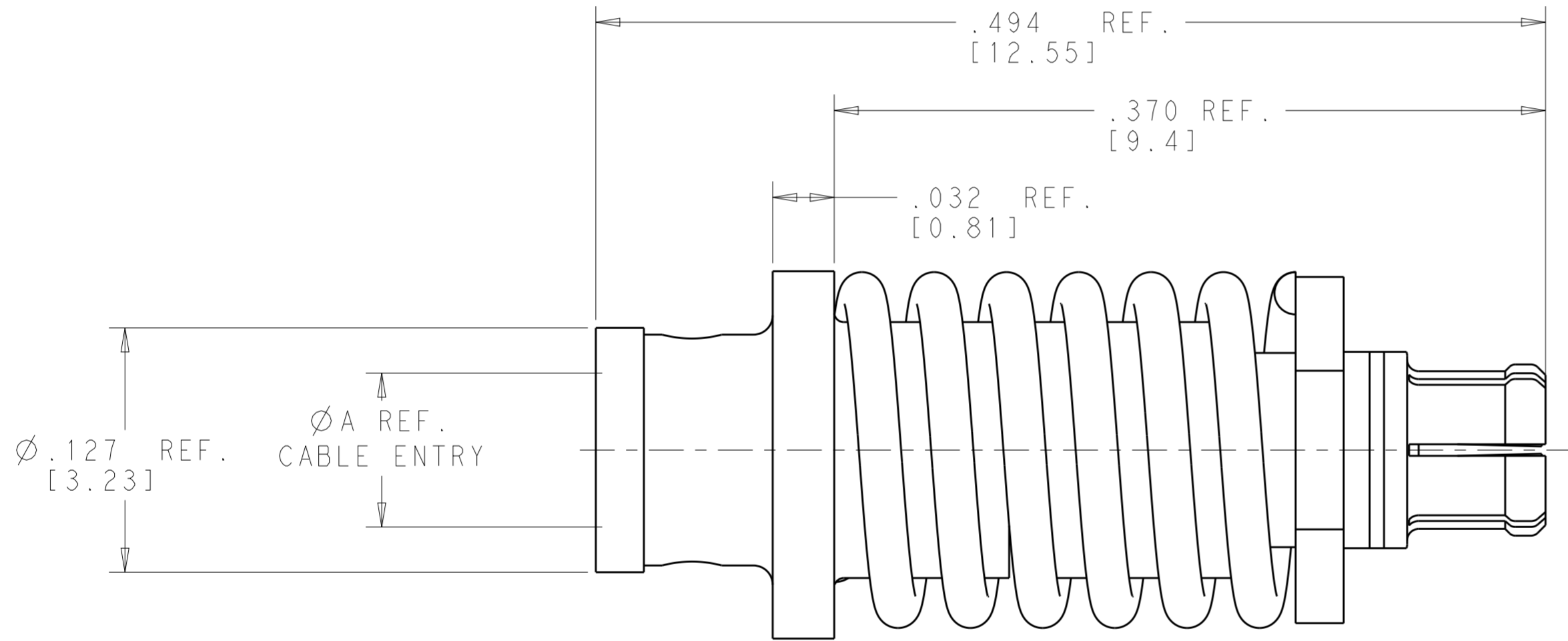

CABLE PREPARATION

CC-.0201 [0.51] NOM BRD-.078 [1.98] NOM	.083 [2.11]	2101814-2
CC-.0197 [0.5] NOM BRD-.0756 [1.92] NOM	.080 [2.03]	2101814-1
CABLE	DIM A	PART NUMBER

THIS DRAWING IS A CONTROLLED DOCUMENT.		DWN 07JUL2010 S.T. Morley	<b>STE</b> TE Connectivity	
DIMENSIONS: INCHES [mm]		CHK 07JUL2010 S.T. Morley		
TOLERANCES UNLESS OTHERWISE SPECIFIED:		APVD 07JUL2010 S.T. Morley	NAME SMPM STRAIGHT CABLE JACK (F) FLOATING PANEL MOUNT - FOR USE WITH LOW LOSS CABLE	
0 PLC ±.1	1 PLC ±.01	PRODUCT SPEC	SIZE CAGE CODE DRAWING NO	
2 PLC ±.005	3 PLC ±.0005	APPLICATION SPEC	RESTRICTED TO	
4 PLC ±.0005	ANGLES ±1.0°	408-10373	A200779 C-2101814	
MATERIAL	FINISH	WEIGHT	CUSTOMER DRAWING	
1	2		SCALE 15:1 SHEET 1 OF 1 REV E	