

LOC		DIST		REVISIONS			
F	LTR	DESCRIPTION	DATE	DMN	APVD		
D		EC 003B 1113 04	29DEC05	BSV	DB		
D1		REVISED PER ECO-09-021510	14SEP09	KK	AEG		

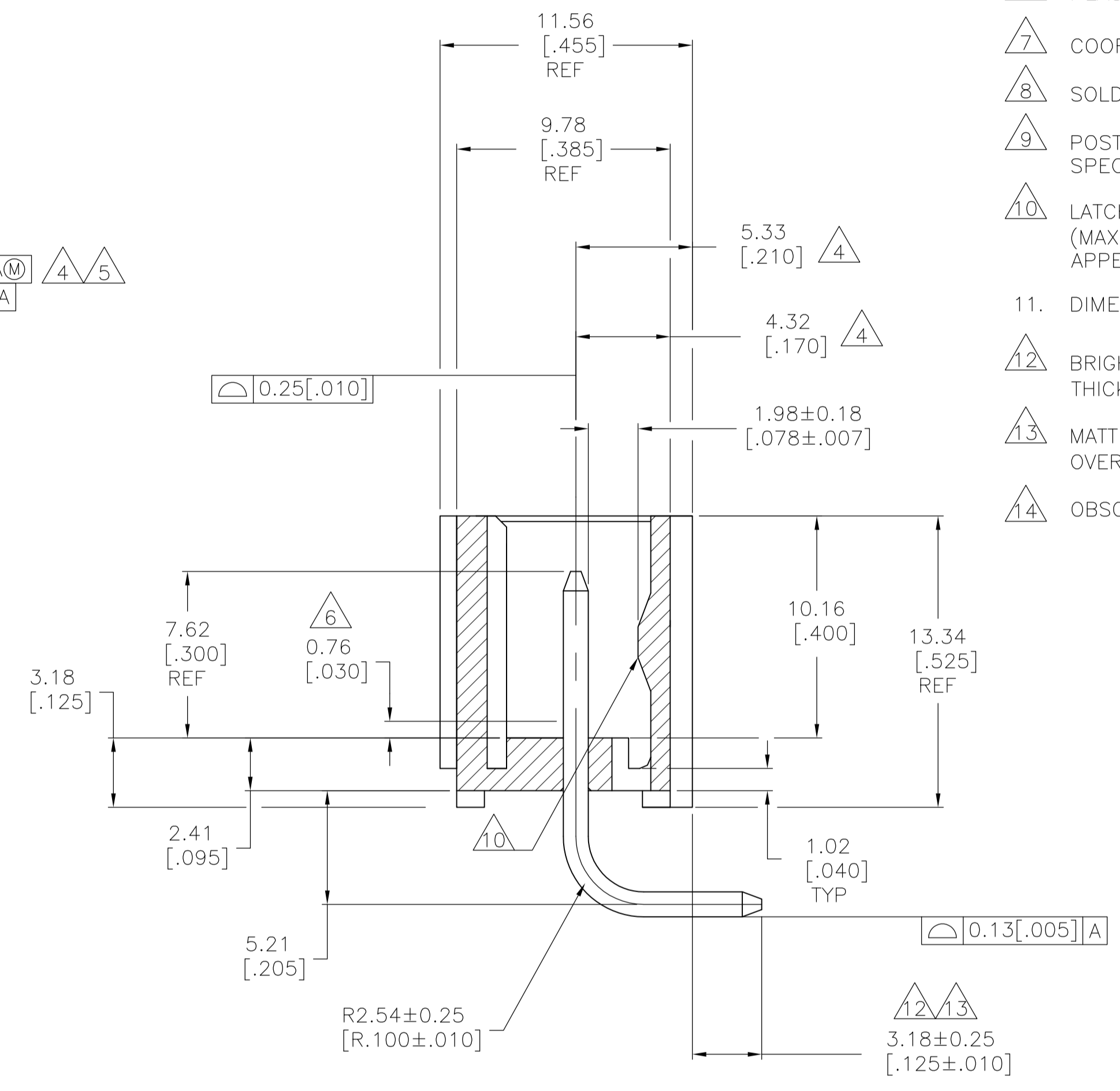

- 1 MATERIAL:
HOUSING - THERMOPLASTIC POLYESTER, GLASS FILLED, UL94-0.
POST - COPPER ALLOY
- 2 FINISH:
HOUSING - BLACK
POST - SEE NOTES 12 AND 13.
- 3 POST TO WITHSTAND 3LBS. (16N) MIN AXIAL FORCE IN THIS DIRECTION WITHOUT DISLODGING.
- 4 APPLIES AT -A-.
- 5 APPLIES WHEN HEADER IS STRAIGHT.
- 6 PLASTIC PROJECTIONS PERMITTED IN THIS ZONE.
- 7 COORDINATE DIMENSIONS APPLIES FROM CENTER OF ACTUAL FEATURE.
- 8 SOLDER SIDE OF BOARD IS SHOWN.
- 9 POST SOLDERTAIL MUST COMPLY WITH AMP SOLDERABILITY SPEC 109-11-2.
- 10 LATCH DETENT FEATURE APPEARS 1 PLACE ON EACH END OF PART (MAX OF 2 PER PART) ON ALL POSITIONS 4 THRU 12. THE LATCH APPEARS ONLY ONE PLACE ON 2 & 3 POSITION PARTS.
- 11. DIMENSIONS IN BRACKETS ARE IN INCHES.
- 12 BRIGHT TIN LEAD (93/7) PLATE 0.00381 - 0.00889 [.000150 - .000350] THICK, OVER NICKEL UNDERPLATE 0.00127 [.000050] MIN THICK.
- 13 MATTE TIN PLATE 0.00381 - 0.00889 [.000150 - .000350] THICK, OVER NICKEL UNDERPLATE 0.00127 [.000050] MIN THICK.
- 14 OBSOLETE PARTS: OBSOLETE CIS STREAMLINING PER D.RENAUD/D.SINISI

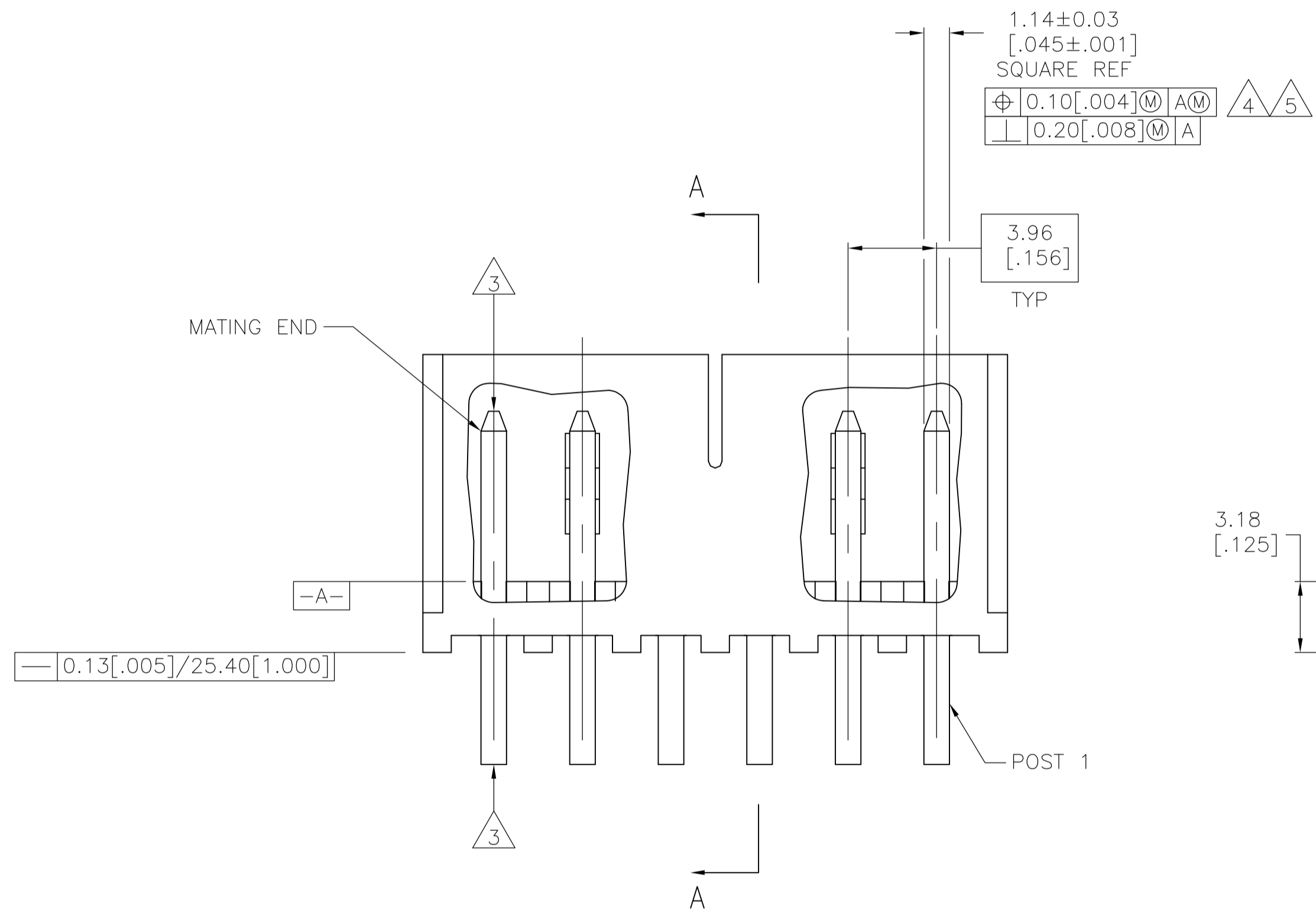
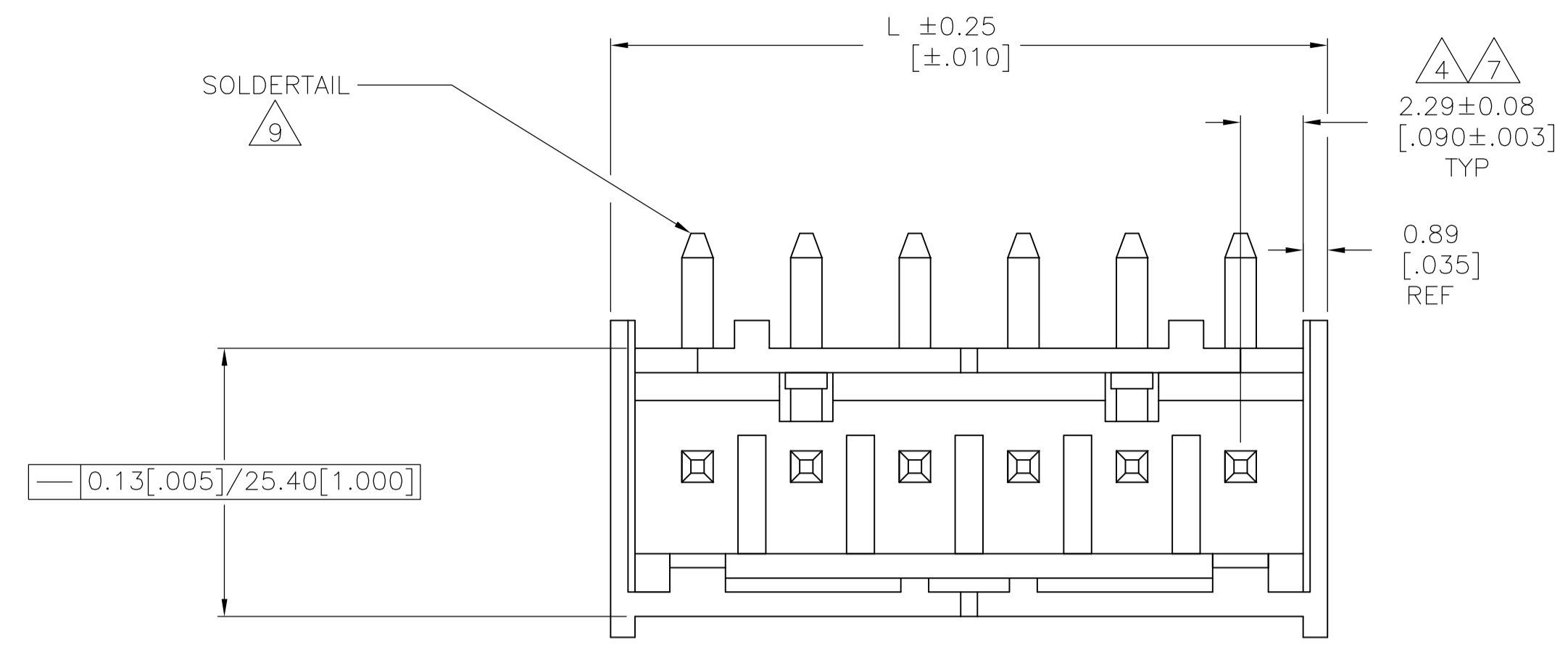
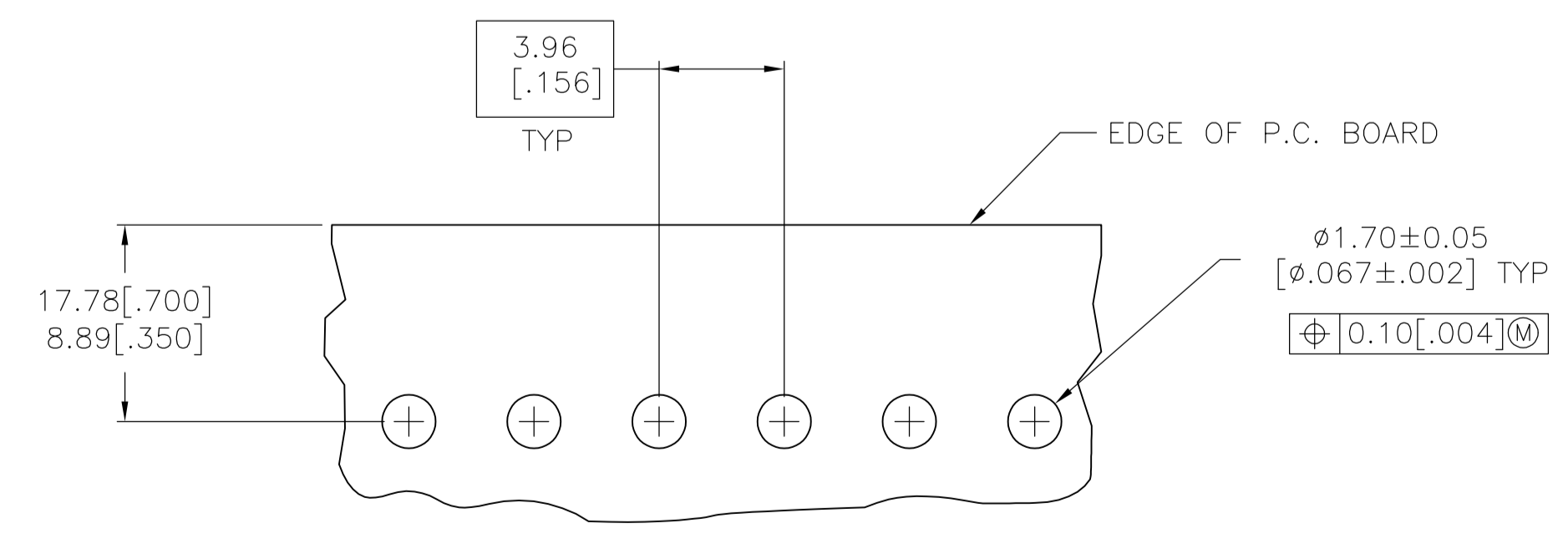
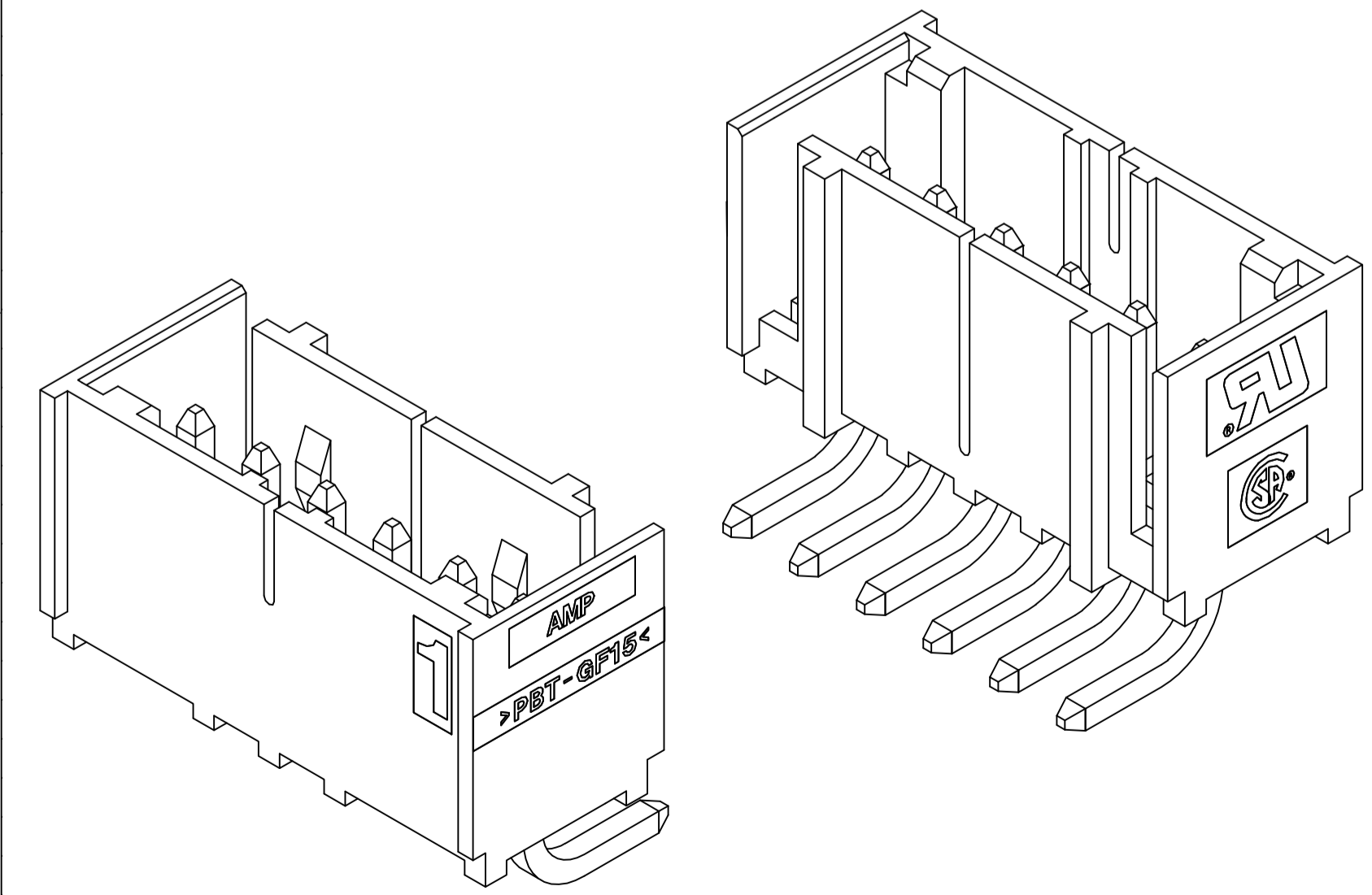
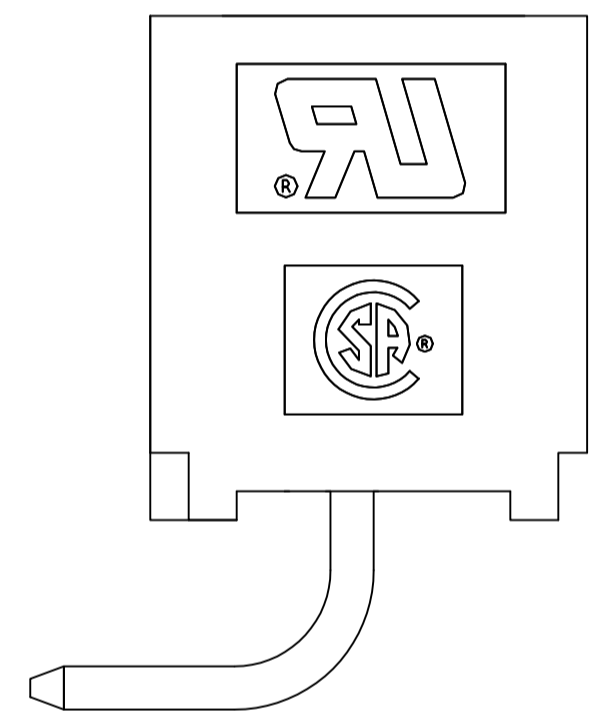

SECTION A-A
 647126-6 SHOWN

PLATING	MM	IN	NO. OF POSN	PART NUMBER	
					L
SUPERSEDED	49.94	1.966	12	3-647126-2	
	45.97	1.810	11	3-647126-1	
	42.01	1.654	10	3-647126-0	
	38.05	1.498	9	2-647126-9	
	34.09	1.342	8	2-647126-8	
	30.12	1.186	7	2-647126-7	
	26.16	1.030	6	2-647126-6	
	22.20	.874	5	2-647126-5	
	18.24	.718	4	2-647126-4	
	14.27	.562	3	2-647126-3	
	10.31	.406	2	2-647126-2	
	SUPERSEDED	49.94	1.966	12	1-647126-2
		45.97	1.810	11	1-647126-1
42.01		1.654	10	1-647126-0	
38.05		1.498	9	647126-9	
34.09		1.342	8	647126-8	
30.12		1.186	7	647126-7	
	26.16	1.030	6	647126-6	
	22.20	.874	5	647126-5	
	18.24	.718	4	647126-4	
	14.27	.562	3	647126-3	
	10.31	.406	2	647126-2	

METRIC

THIS DRAWING IS A CONTROLLED DOCUMENT.

DIN	B. LEWIS	17JUN98	Tyco Electronics Corporation
CHK	R. SWING	17JUN98	Harrisburg, PA 17105-3608
APP'D	D. CLARK	17JUN98	NAME
DIMENSIONS: mm [INCHES]		TOLERANCES UNLESS OTHERWISE SPECIFIED:	
0. PLC	± .005	0.005	
1. PLC	± .005	0.005	
2. PLC	± .005	0.005	
3. PLC	± .005	0.005	
4. PLC	± .005	0.005	
ANGLES	± .005	0.005	
MATERIAL		SIZE	CAGE CODE DRAWING NO
		A1	00779C=647126
WEIGHT		CUSTOMER DRAWING	SCALE 5:1 SHEET 1 OF 1 REV D1