

LTC2636

Octal 12-Bit SPI V_{OUT} DACs with 10ppm/ $^{\circ}$ C Internal Reference

DESCRIPTION

Demonstration circuit 1466B features the [LTC[®]2636](#) Octal 12-bit DAC. This device has an integrated, high accuracy, low-drift reference. It has a rail-to-rail output buffer and is guaranteed monotonic. This DAC communicates through the simple SPI compatible interface.

Design files for this circuit board are available at <http://www.linear.com/demo/DC1466B>

LT, LT, LTC, LTM, Linear Technology and the Linear logo are registered trademarks and QuikEval is a trademark of Linear Technology Corporation. All other trademarks are the property of their respective owners.

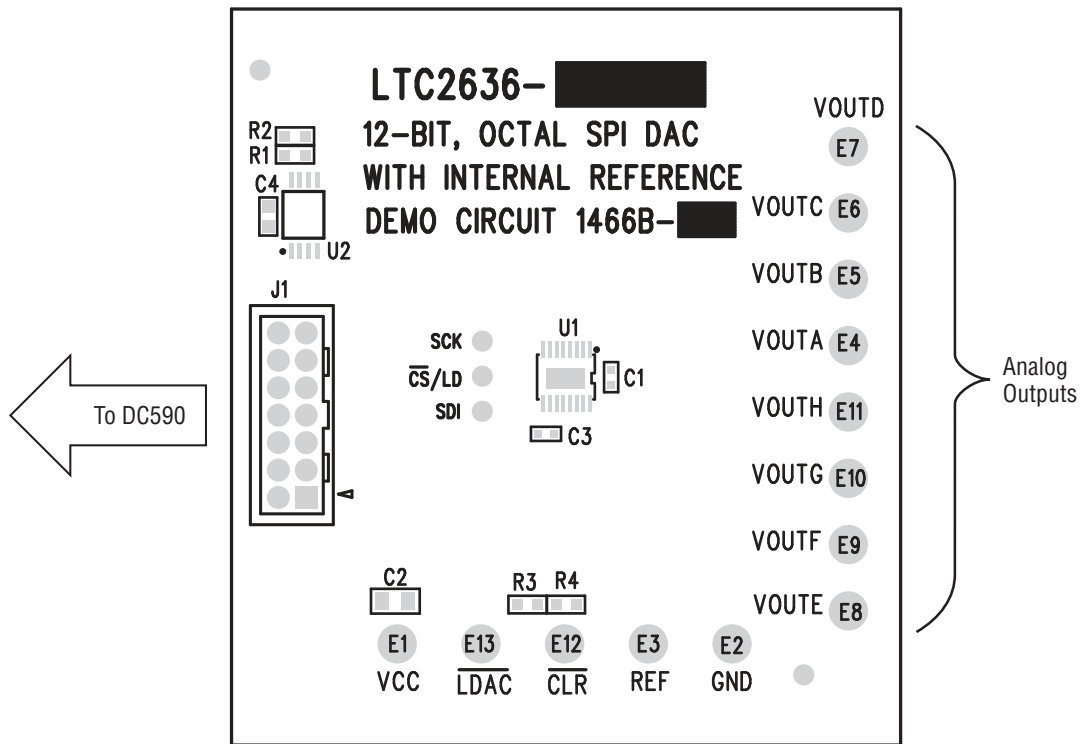

Figure 1

Table 1.

DEMO BOARD TYPE	LTC2636 VARIATION (SUFFIX)	POWER-UP OUTPUT	FULL-SCALE OUTPUT VOLTAGE
A	LZ	Zero	2.5V
B	LMI	Mid-Scale	2.5V
C	HZ	Zero	4.096V
D	HMI	Mid-Scale	4.096V

QUICK START PROCEDURE

Connect DC1466B to a DC590 USB serial controller using the supplied 14 conductor ribbon cable. Connect DC590 to a host PC with a standard USB A/B cable. Run the QuikEval™ evaluation software supplied with DC590 or download it from www.linear.com/software. The correct control panel will be loaded automatically. The DAC is updated as changes are made to the GUI screen. Entering a voltage into a text box will cause the DAC's output to

update immediately. Values may be entered in voltage, hexadecimal counts, or decimal counts by selecting the appropriate radio button. The reference mode may also be changed, and individual DACs can be powered down by unchecking the "Enable" box.

Complete software documentation is available from the Help menu item, as features may be added periodically.

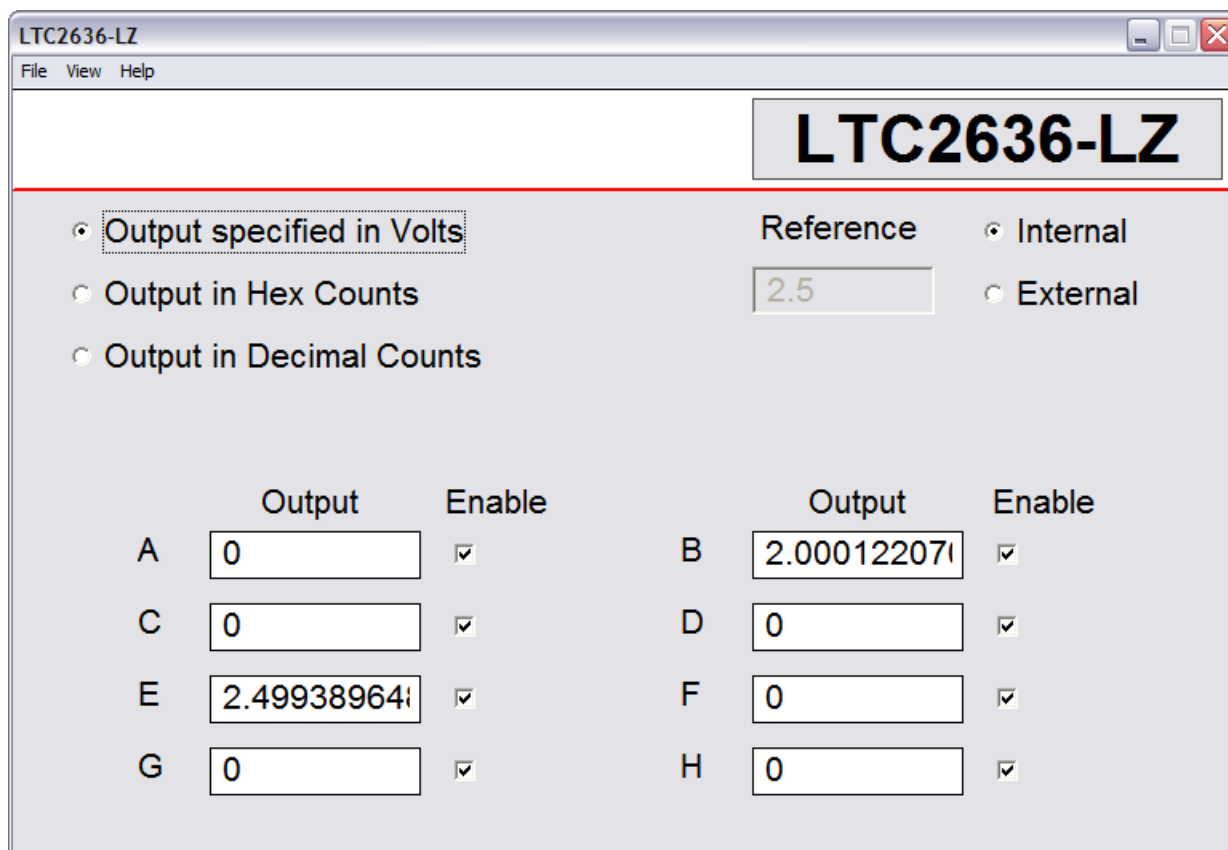

Figure 2

HARDWARE SETUP

Analog Connections

DAC Outputs – The eight DAC outputs from the LTC2636 are brought out to turrets labeled VOUTA through VOUTH. These may be connected to external instruments or other circuitry.

DAC outputs are not in alphabetical order on the circuit board.

REF – The REF turret is connected directly to the reference pin of the LTC2636. When the integrated reference is being used, the reference voltage may be monitored at this point. An external reference may also be applied to this turret after changing the setting in the evaluation software.

Digital Connections

$\overline{\text{LDAC}}$ – Load pin, active low, pulled to V_{CC} by a 10k resistor. Updates the DAC register from the Input register. Do not assert this pin when using with the evaluation software. This pin can be used to update all DACs simultaneously, after individual input registers have been written to.

$\overline{\text{CLR}}$ – Clear pin, active low, pulled to V_{CC} by a 10k resistor. Asserting this pin clears all DACs to their default power-up value.

Grounding and Power Connections

Power (V_{CC}) – Normally DC1466 is powered by the DC590 controller. V_{CC} can be supplied to this turret, however the power supply on DC590 must be disabled! Refer to DC590 Quick Start Guide for more details on this mode of operation.

Grounding – Ground turrets as well as 2 grounding strips are provided.

DEMO MANUAL DC1466B

PARTS LIST

ITEM	QTY	REFERENCE	PART DESCRIPTION	MANUFACTURER/PART NUMBER
Parts List – All Assembly Types				
1	2	C1, C3	CAP., X5R, 0.1µF, 16V, 10%, 0402	AVX, 0402YD104KAT
2	1	C4	CAP., X7R, 0.1µF, 16V, 10%, 0603	AVX, 0603YC104KAT
3	1	C2	CAP., X5R, 10µF, 16V, 10%, 0805	AVX, 0805YD106KAT
4	13	E1–E13	TESTPOINT, TURRET, 0.065"	MILL-MAX, 2308-2-00-80-00-00-07-0
5	1	J1	HEADER, 2×7 PIN, 0.079CC	MOLEX, 87831-1420
6	2	R1, R2	RES., CHIP, 4.99k, 1/16W, 1%, 0603	VISHAY, CRCW06034K99FKEA
7	2	R3, R4	RES., CHIP, 10k, 1/16W, 1%, 0603	VISHAY, CRCW06010K0FKEA
8	1	U2	IC, EEPROM 2k BIT 400kHz 8 TSSOP	MICROCHIP, 24LC025-I/ST
Parts List – DC1466B-A				
2	1	U1	LTC2636CMS-LZ12#PBF, MSOP 16-PIN	LINEAR TECH., LTC2636CMS-LZ12#PBF
Parts List – DC1466B-B				
2	1	U1	LTC2636CMS-LMI12#PBF, MSOP 16-PIN	LINEAR TECH., LTC2636CMS-LMI12#PBF
Parts List – DC1466B-C				
2	1	U1	LTC2636CMS-HZ12#PBF, MSOP 16-PIN	LINEAR TECH., LTC2636CMS-HZ12#PBF
Parts List – DC1466B-D				
2	1	U1	LTC2636CMS-HMI12#PBF, MSOP 16-PIN	LINEAR TECH., LTC2636CMS-HMI12#PBF

BOARD REVISION HISTORY

BOARD REV	DATE	DESCRIPTION
A		Original Design
B	10/13	Connected Floating Address Lines on ID EEPROM.

SCHEMATIC DIAGRAM

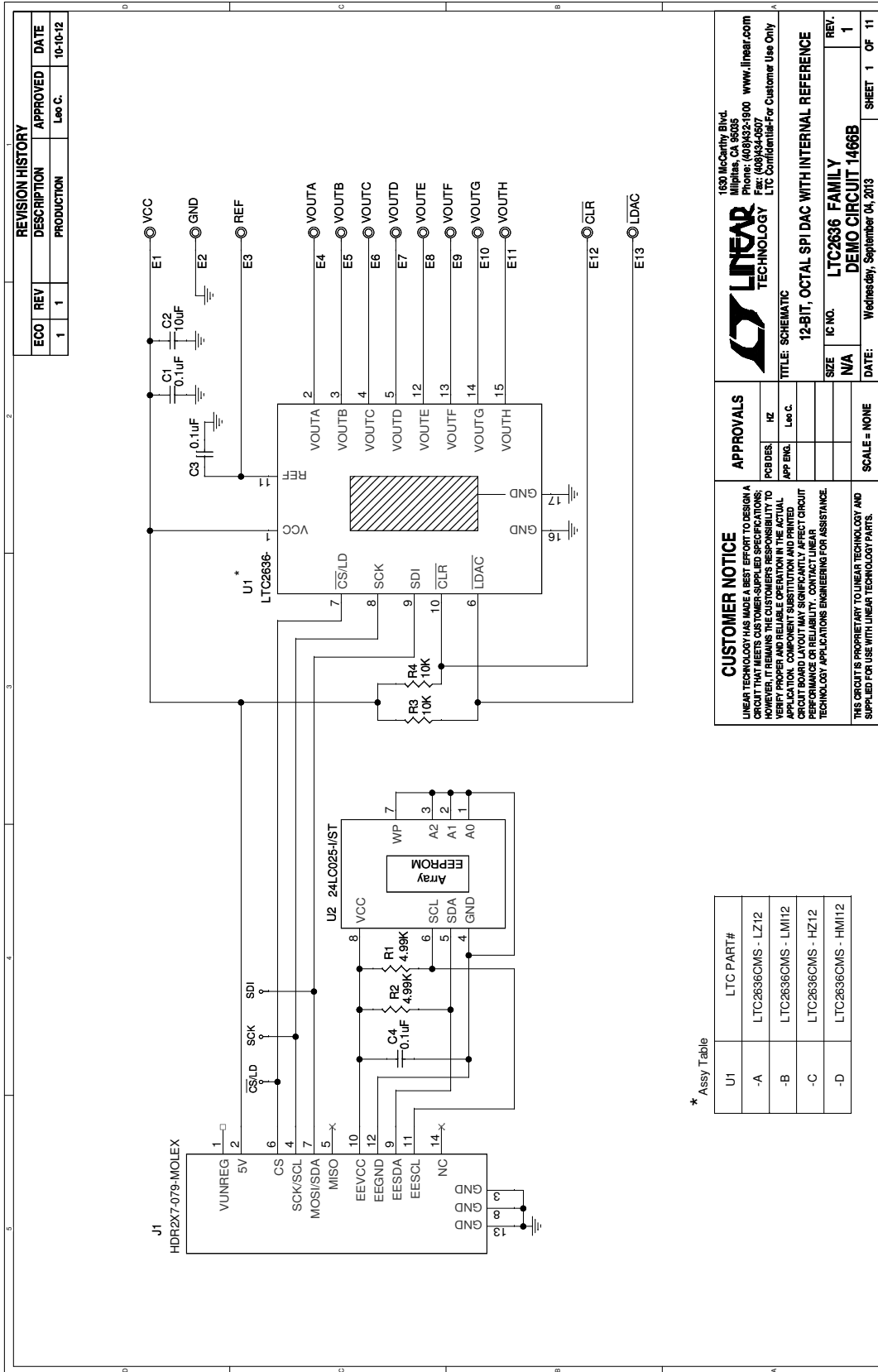

REVISION HISTORY		
ECO	REV	DESCRIPTION
1	1	PRODUCTION

APPROVED	DATE
Leo C.	10-10-12

1530 McCarthy Blvd.
Milpitas, CA 95035
Phone: (408)432-1900 www.linear.com
Fax: (408)434-0507
LTC Confidential-For Customer Use Only

LINEAR TECHNOLOGY

TITLE: SCHEMATIC

12-BIT, OCTAL SPI DAC WITH INTERNAL REFERENCE

SIZE	NA	REV.	1
IC NO.	LTC2636 FAMILY		
DATE:	Wednesday, September 04, 2013	SHEET	1 OF 11

SCALE = NONE

CUSTOMER NOTICE
LINEAR TECHNOLOGY HAS MADE A BEST EFFORT TO DESIGN A CIRCUIT THAT MEETS CUSTOMER-SUPPLIED SPECIFICATIONS; HOWEVER, IT REMAINS THE CUSTOMER'S RESPONSIBILITY TO VERIFY PROPER AND RELIABLE OPERATION IN THE ACTUAL APPLICATION. THE BOARD LAYOUT MAY SIGNIFICANTLY AFFECT CIRCUIT PERFORMANCE OR RELIABILITY. CONTACT LINEAR TECHNOLOGY APPLICATIONS ENGINEERING FOR ASSISTANCE.

THIS CIRCUIT IS PROPRIETARY TO LINEAR TECHNOLOGY AND SUPPLIED FOR USE WITH LINEAR TECHNOLOGY PARTS.

* Assy Table

U1	LTC PART#
-A	LTC2636CMS - LZ12
-B	LTC2636CMS - LM12
-C	LTC2636CMS - HZ12
-D	LTC2636CMS - HM12



Information furnished by Linear Technology Corporation is believed to be accurate and reliable. However, no responsibility is assumed for its use. Linear Technology Corporation makes no representation that the interconnection of its circuits as described herein will not infringe on existing patent rights.

DEMO MANUAL DC1466B

DEMONSTRATION BOARD IMPORTANT NOTICE

Linear Technology Corporation (LTC) provides the enclosed product(s) under the following **AS IS** conditions:

This demonstration board (DEMO BOARD) kit being sold or provided by Linear Technology is intended for use for **ENGINEERING DEVELOPMENT OR EVALUATION PURPOSES ONLY** and is not provided by LTC for commercial use. As such, the DEMO BOARD herein may not be complete in terms of required design-, marketing-, and/or manufacturing-related protective considerations, including but not limited to product safety measures typically found in finished commercial goods. As a prototype, this product does not fall within the scope of the European Union directive on electromagnetic compatibility and therefore may or may not meet the technical requirements of the directive, or other regulations.

If this evaluation kit does not meet the specifications recited in the DEMO BOARD manual the kit may be returned within 30 days from the date of delivery for a full refund. **THE FOREGOING WARRANTY IS THE EXCLUSIVE WARRANTY MADE BY THE SELLER TO BUYER AND IS IN LIEU OF ALL OTHER WARRANTIES, EXPRESSED, IMPLIED, OR STATUTORY, INCLUDING ANY WARRANTY OF MERCHANTABILITY OR FITNESS FOR ANY PARTICULAR PURPOSE. EXCEPT TO THE EXTENT OF THIS INDEMNITY, NEITHER PARTY SHALL BE LIABLE TO THE OTHER FOR ANY INDIRECT, SPECIAL, INCIDENTAL, OR CONSEQUENTIAL DAMAGES.**

The user assumes all responsibility and liability for proper and safe handling of the goods. Further, the user releases LTC from all claims arising from the handling or use of the goods. Due to the open construction of the product, it is the user's responsibility to take any and all appropriate precautions with regard to electrostatic discharge. Also be aware that the products herein may not be regulatory compliant or agency certified (FCC, UL, CE, etc.).

No License is granted under any patent right or other intellectual property whatsoever. **LTC assumes no liability for applications assistance, customer product design, software performance, or infringement of patents or any other intellectual property rights of any kind.**

LTC currently services a variety of customers for products around the world, and therefore this transaction **is not exclusive**.

Please read the DEMO BOARD manual prior to handling the product. Persons handling this product must have electronics training and observe good laboratory practice standards. **Common sense is encouraged.**

This notice contains important safety information about temperatures and voltages. For further safety concerns, please contact a LTC application engineer.

Mailing Address:

Linear Technology
1630 McCarthy Blvd.
Milpitas, CA 95035

Copyright © 2004, Linear Technology Corporation