

USB Type-C™ Mini Dock EVM

This user's guide provides an overview and operating instructions for TI's *USB Type-C Mini Dock EVM*. A quick-start guide section and schematics are also included in the document. Throughout this document, the abbreviations *dock*, *EVM*, *EVM board*, and the term *evaluation module* are synonymous with *USB Type-C Mini Dock EVM*, unless otherwise noted.

Contents

1	What is the TI USB Type-C Dock?	2
2	TI USB Type-C Mini Dock Features	3
3	USB Type-C Mini Dock Quick-Start Guide	4
4	Schematics	6

List of Figures

1	USB Type-C Mini Dock Block Diagram	2
2	USB Type-C Mini Dock EVM	3
3	USB Type-C Dock Example Setup	4
4	USB Type-C Dock Example Setup	5
5	USB Type-C Dock Example Setup	5
6	EVM Board Power Schematic	6
7	EVM Board Power 2 Schematic	7
8	USB Type-C Front End Schematic	8
9	TPS65986 Schematic	9
10	TUSB8041 Schematic	10
11	Port 1 Downstream USB Schematic	11
12	Port 2 Downstream USB Type-C Schematic	12
13	Port 2 USB Type-C Schematic	13
14	Port 3 USB Audio Schematic	14
15	Port 4 USB Type-C Charging Schematic	15
16	Port 4 USB Type-C Connector Schematic	16
17	DP4320 Schematic	17
18	DP4320 Power Schematic	18
19	DP4320 Bootstrap Schematic	19
20	EVM Display Port Schematic	20
21	DP to HDMI Schematic	21
22	EVM HDMI Connector Schematic	22
23	Debug Board Schematic	23
24	EVM Schematic Fab Notes	24

List of Tables

1	LEDs for Debug	4
---	----------------------	---

Trademarks

Type-C is a trademark of USB Implementers Forum, Inc..

1 What is the TI USB Type-C Dock?

The USB Type-C and Power Delivery (PD) mini-dock evaluation module (EVM) provides a complete reference solution for a USB Type-C dock including audio, USB data, power, and video. The EVM has a small 2 in x 4 in form factor and supports both source and sink power capabilities over the primary USB Type-C PD port. Video output capabilities include both DisplayPort and HDMI

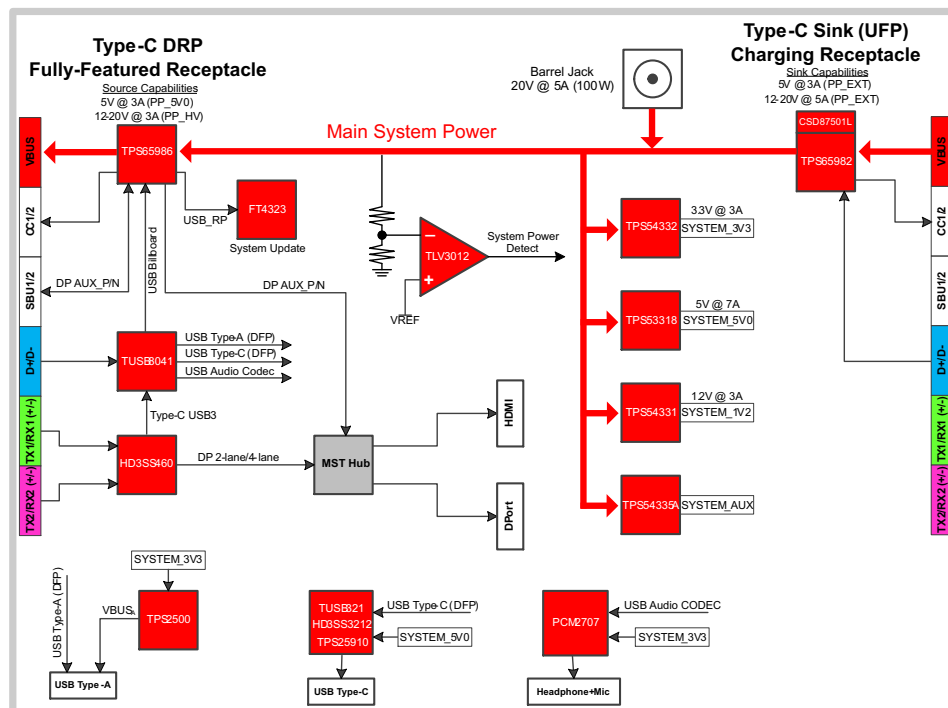

Figure 1. USB Type-C Mini Dock Block Diagram

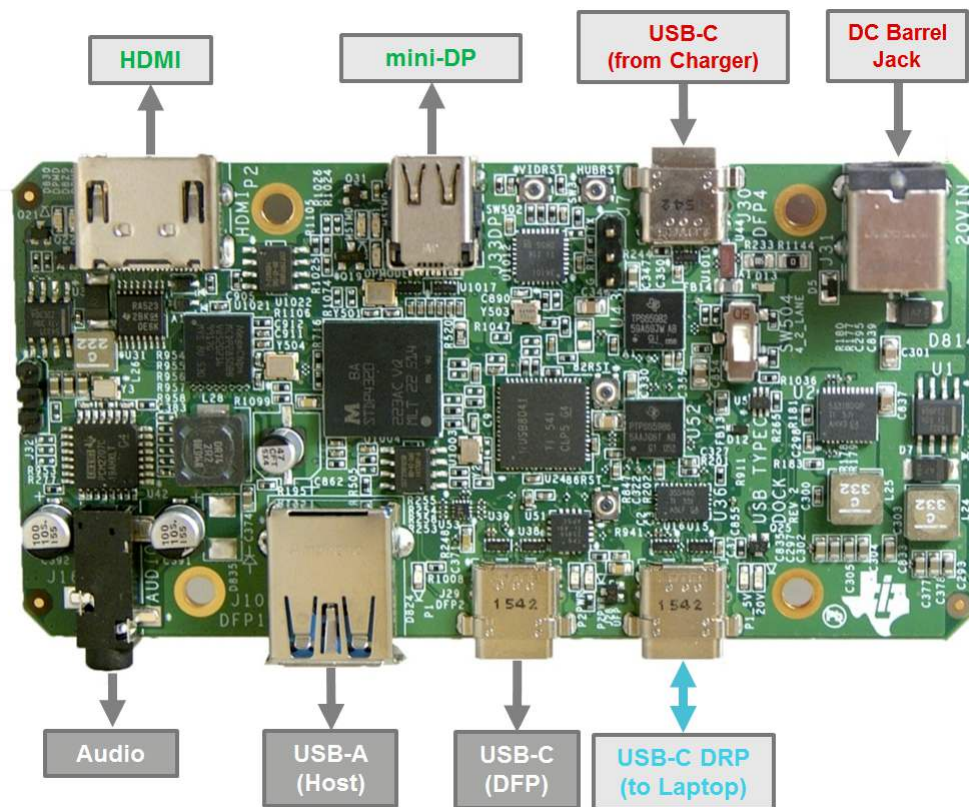

Figure 2. USB Type-C Mini Dock EVM

2 TI USB Type-C Mini Dock Features

This section lists and details supported features of the EVM:

- Power
 - This EVM has the following bi-directional power capabilities:
 - Externally powered by 20-V DC barrel jack (J31). Upon successful power contract negotiation, the dock can source up to 20 V at 3 A.
 - Externally powered by a USB Type-C Charger (J30). Upon successful power contract negotiation, the dock can source 5 V at 3 A or 12–20 V at 5 A.
 - Bus-powered from USB Type-C laptop. Upon successful power contract negotiation, the dock can sink 5 V at 3 A or 12–20 V at 3 A.

D823 or D822 blue LED turns on to indicate if a 20-V or 5-V power input is connected.

- DRP Full-Featured USB-C and PD Port
 - TUSB8041 HUB with upstream connection via HD3SS460 alternate mode switch
 - USB-C DFP using TUSB321 and HD3SS3212
 - USB Type-A DFP
 - 3.5-mm audio jack
- Dual Video (up to 4K) via HDMI or miniDP
- Flash Update Over USB Type-C via USB 2.0 Endpoint

- LEDs
 - [Table 1](#) lists the LEDs provided for easier debug purposes.

Table 1. LEDs for Debug

Reference Designator	LED Name	Description
D820	DP Mode	
D822	5V	Illuminates when 5-V input is present
D823	20V	Illuminates when 20-V input is present
D824	DFP1	Illuminates when Port 1 (J10) is enabled
D825	DFP2	
D826	DFP2	
D827	MS TMD	
D828	MS TMD	
D829	DP MD	
D830	DP MD	

- Firmware (FW) Update
 - Contact Texas Instruments for details on FW updates and see the [USB Type-C Mini Dock Quick-Start Guide](#) section.

3 USB Type-C Mini Dock Quick-Start Guide

The following steps are provided for a quick-start using the EVM:

- Step 1. Connect the *USB Type-C Enabler Board* to the PC with a USB Type-A to USB-B cable and a DisplayPort Cable.
- Step 2. Connect the *USB Type-C Enabler Board* to the *USB Type-C Mini Dock EVM* with a USB Type-C cable.

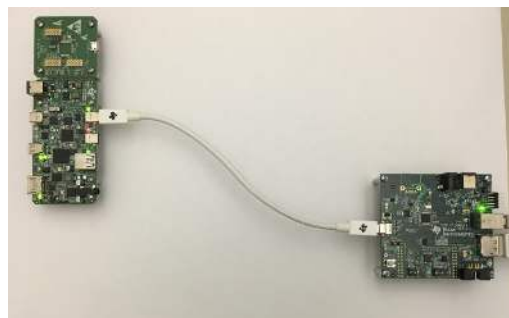

Figure 3. USB Type-C Dock Example Setup

- Step 3. Confirm that D822, D826, D824, D827, D820, D829 are lit.

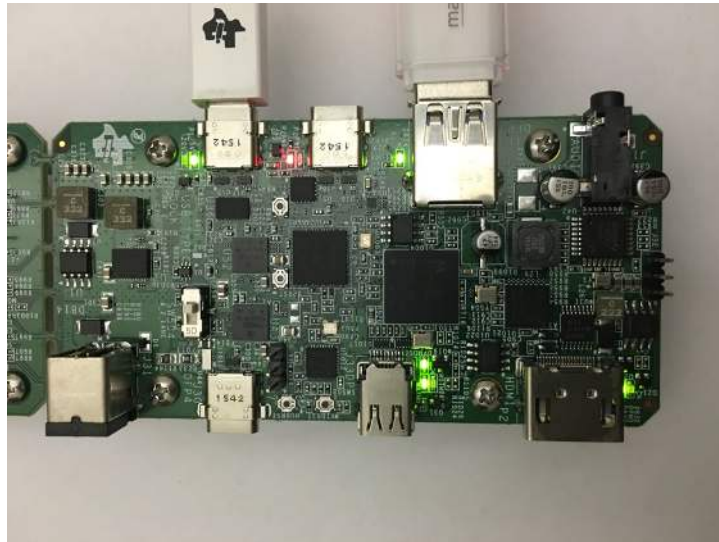

Figure 4. USB Type-C Dock Example Setup

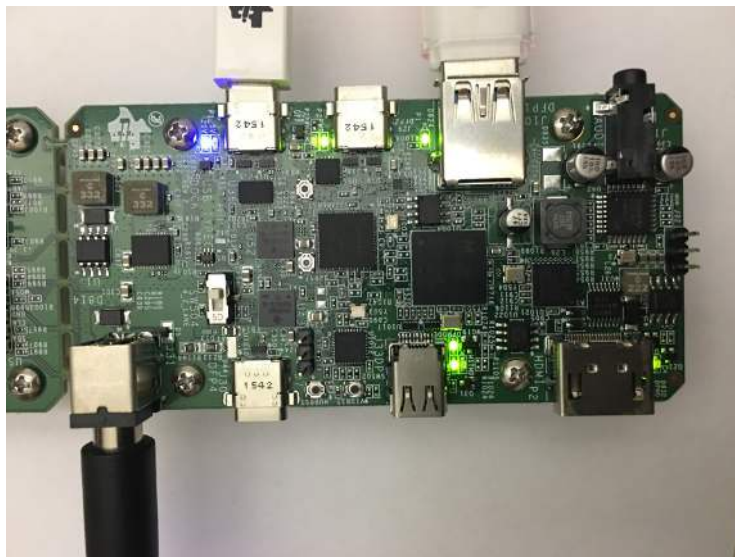

Figure 5. USB Type-C Dock Example Setup

- Step 4. Connect the Dell power adapter and confirm that the D823, D825, D824, D827, D820, D829 are lit.
- Step 5. Connect a USB flash drive to the USB Type-C Mini Dock EVM and confirm that data can be transferred to and from the USB flash drive.
- Step 6. Connect the HDMI cable to the USB Type-C Mini Dock EVM and to a monitor, confirm PC video is displayed on the monitor.
- Step 7. Disconnect the HDMI cable and connect a miniDP cable to the USB Type-C Mini Dock EVM and to a monitor, confirm PC video is displayed on the monitor.

4 Schematics

Figure 6 through Figure 24 illustrate the EVM schematics.

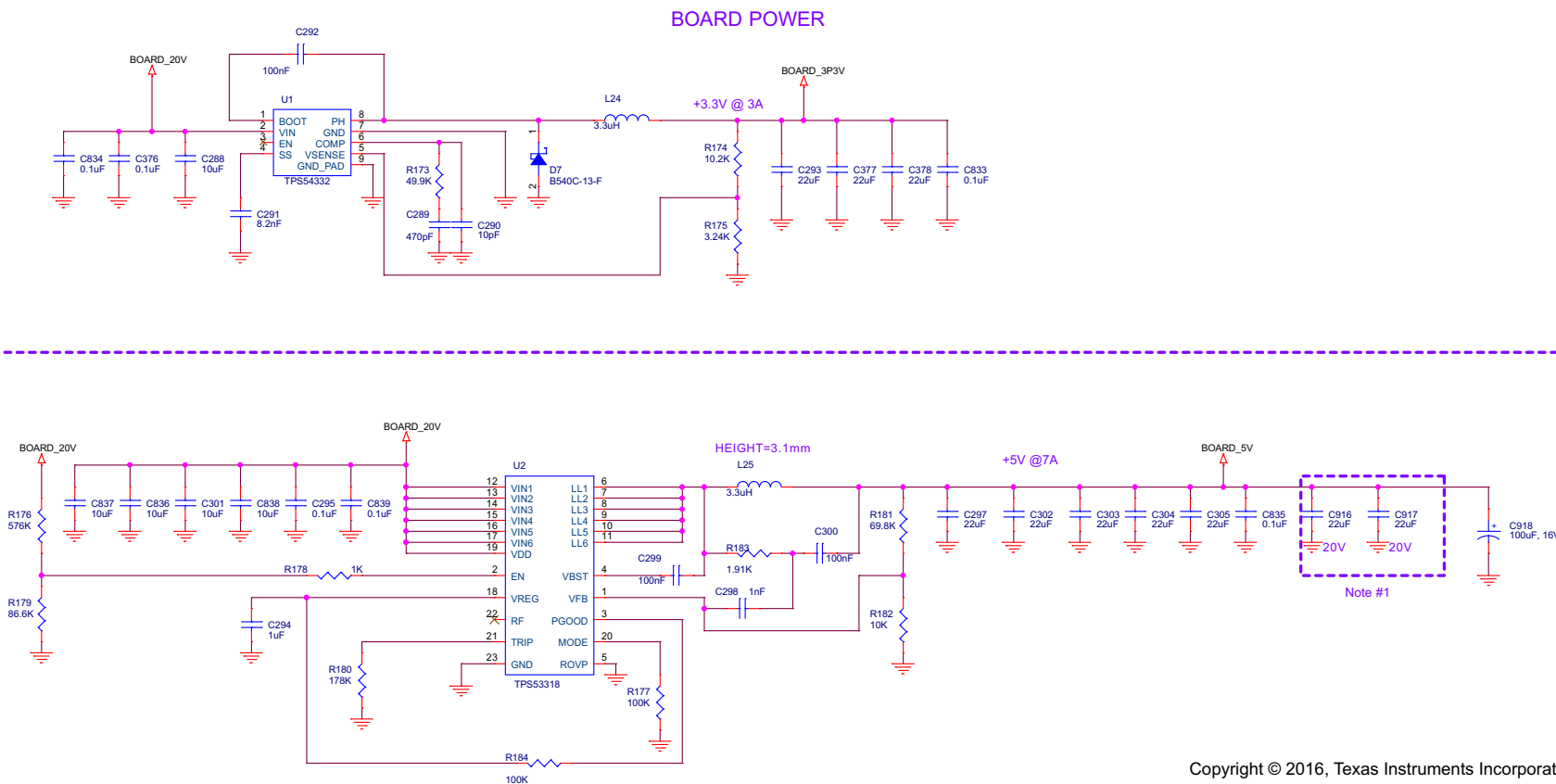
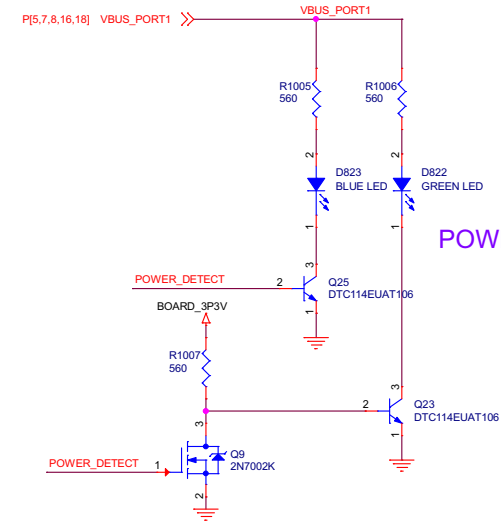
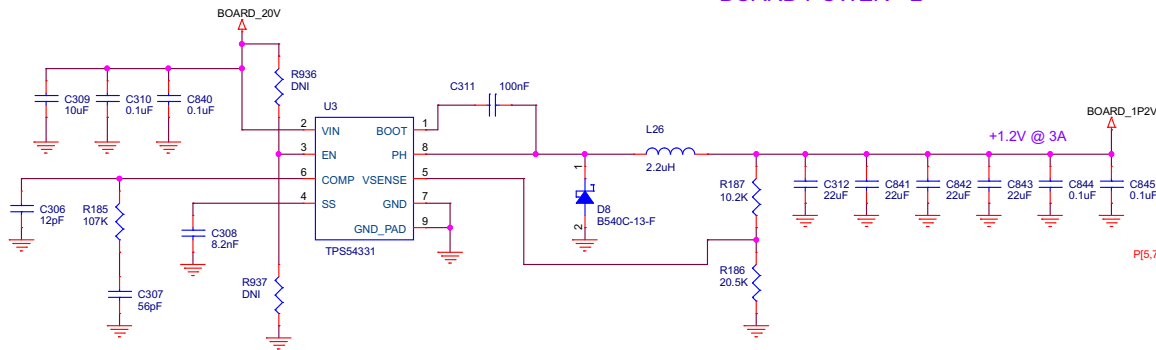
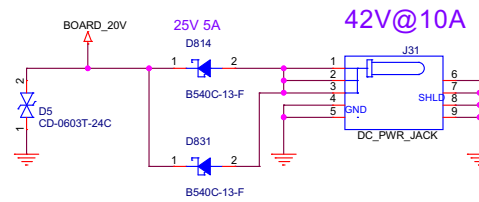
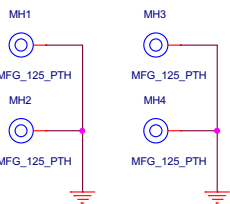
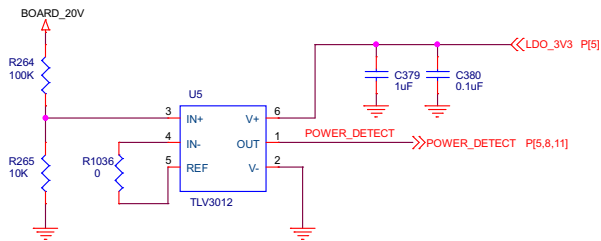

Figure 6. EVM Board Power Schematic

BOARD POWER - 2



POWER LEDS



Copyright © 2016, Texas Instruments Incorporated

Figure 7. EVM Board Power 2 Schematic

USB TYPE C FRONT END

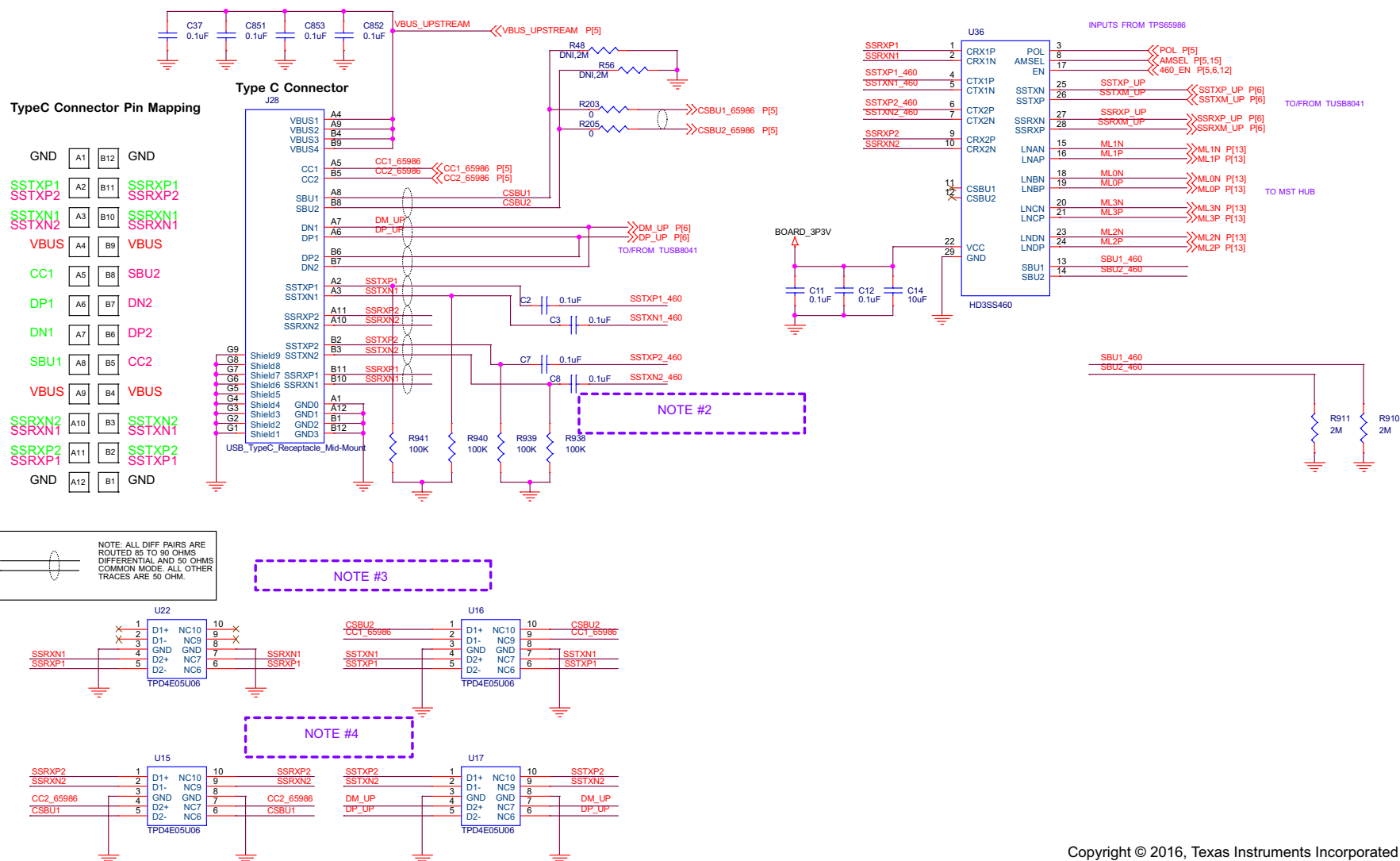
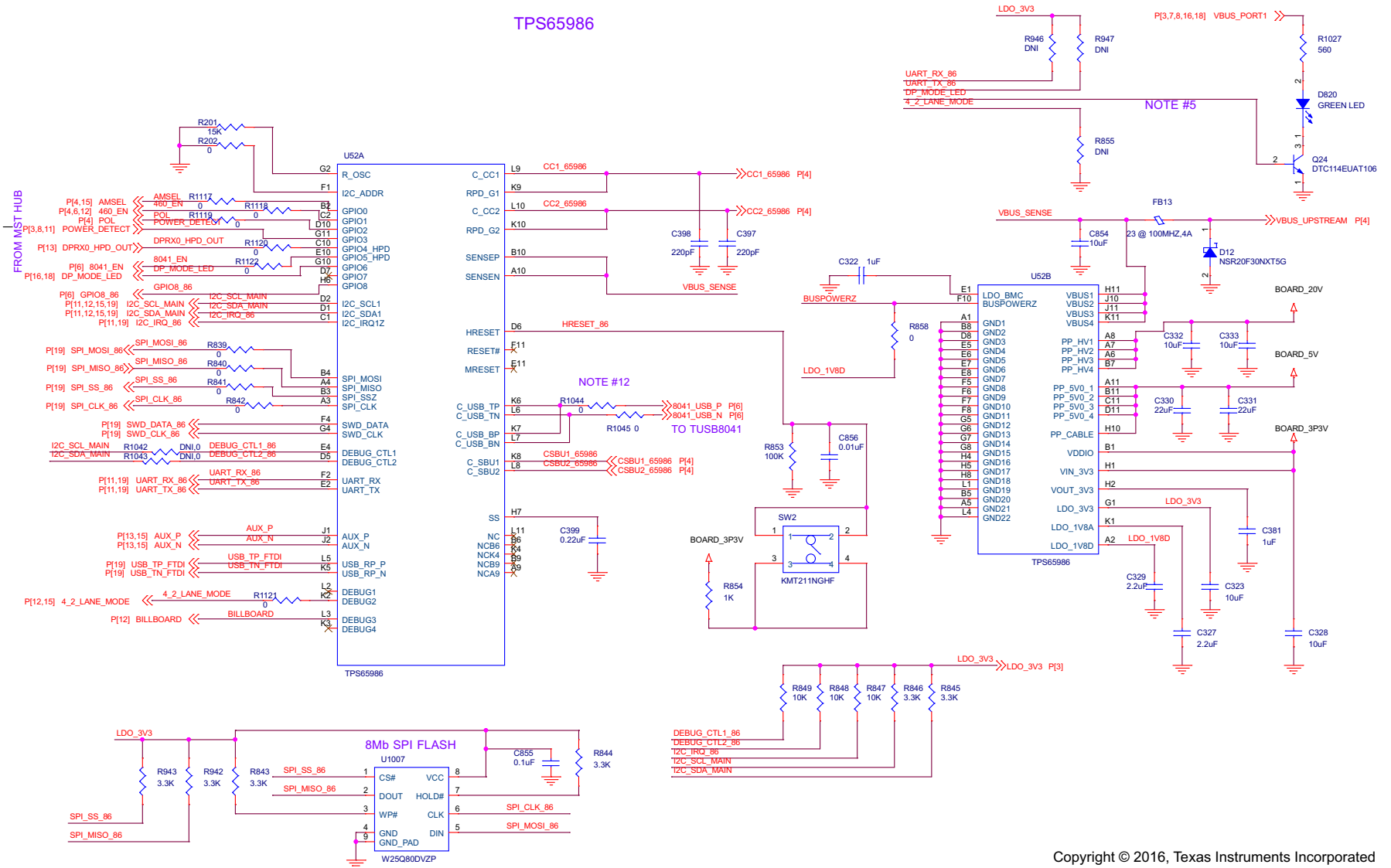

Figure 8. USB Type-C Front End Schematic

Copyright © 2016, Texas Instruments Incorporated



Copyright © 2016, Texas Instruments Incorporated

Figure 9. TPS65986 Schematic

TUSB 4 PORT USB3.0 HUB

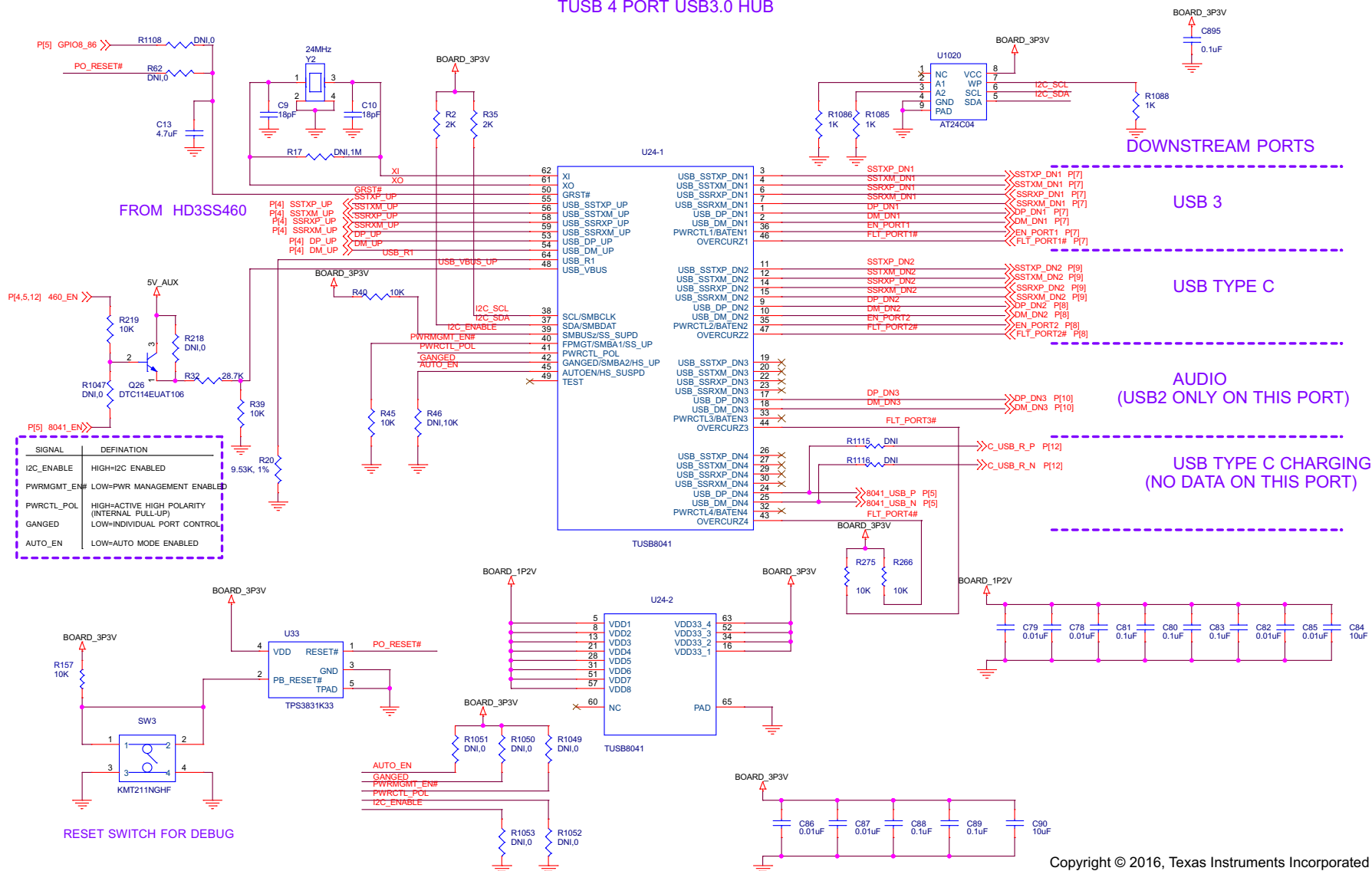

Copyright © 2016, Texas Instruments Incorporated

Figure 10. TUSB8041 Schematic

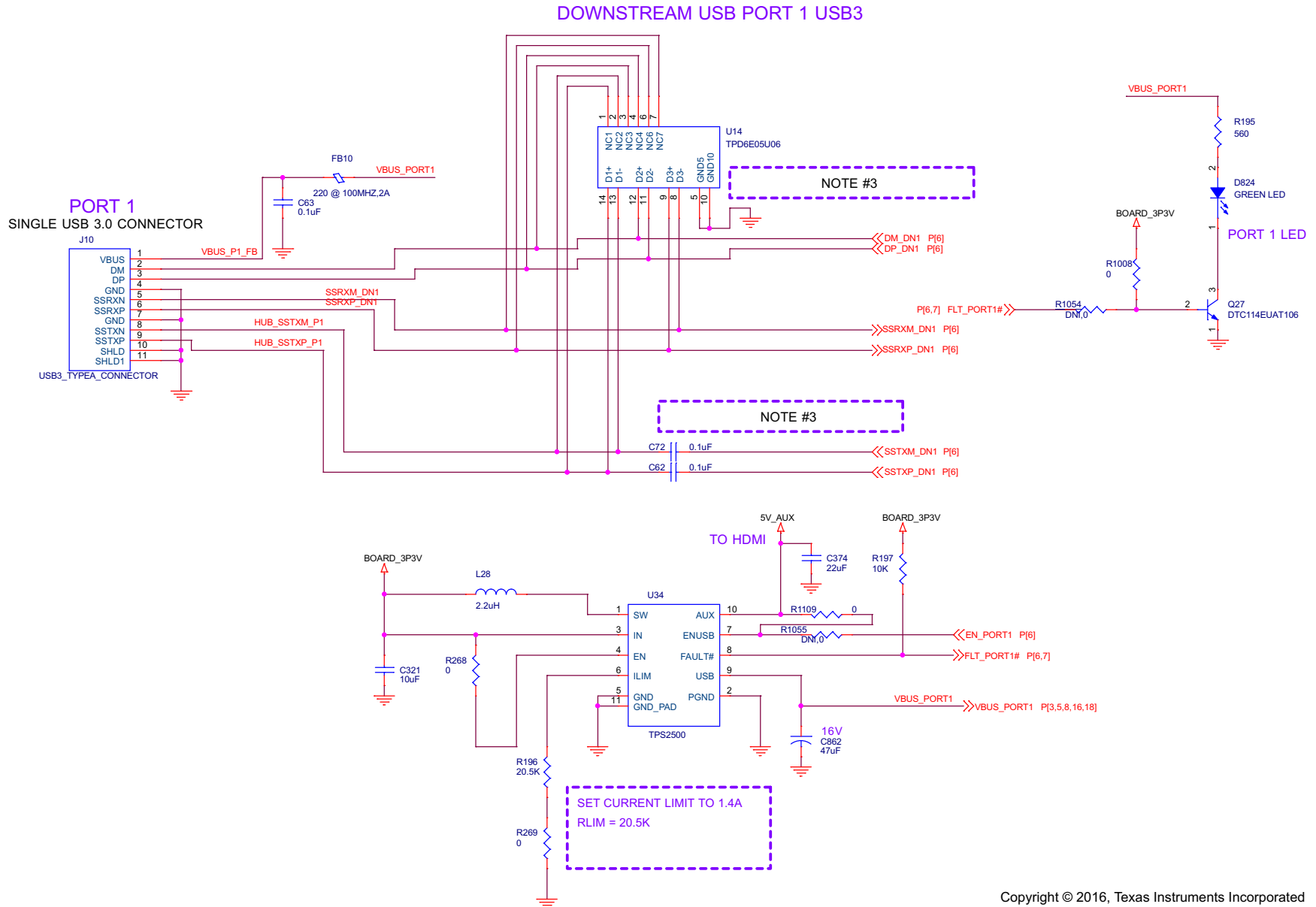

Copyright © 2016, Texas Instruments Incorporated

Figure 11. Port 1 Downstream USB Schematic

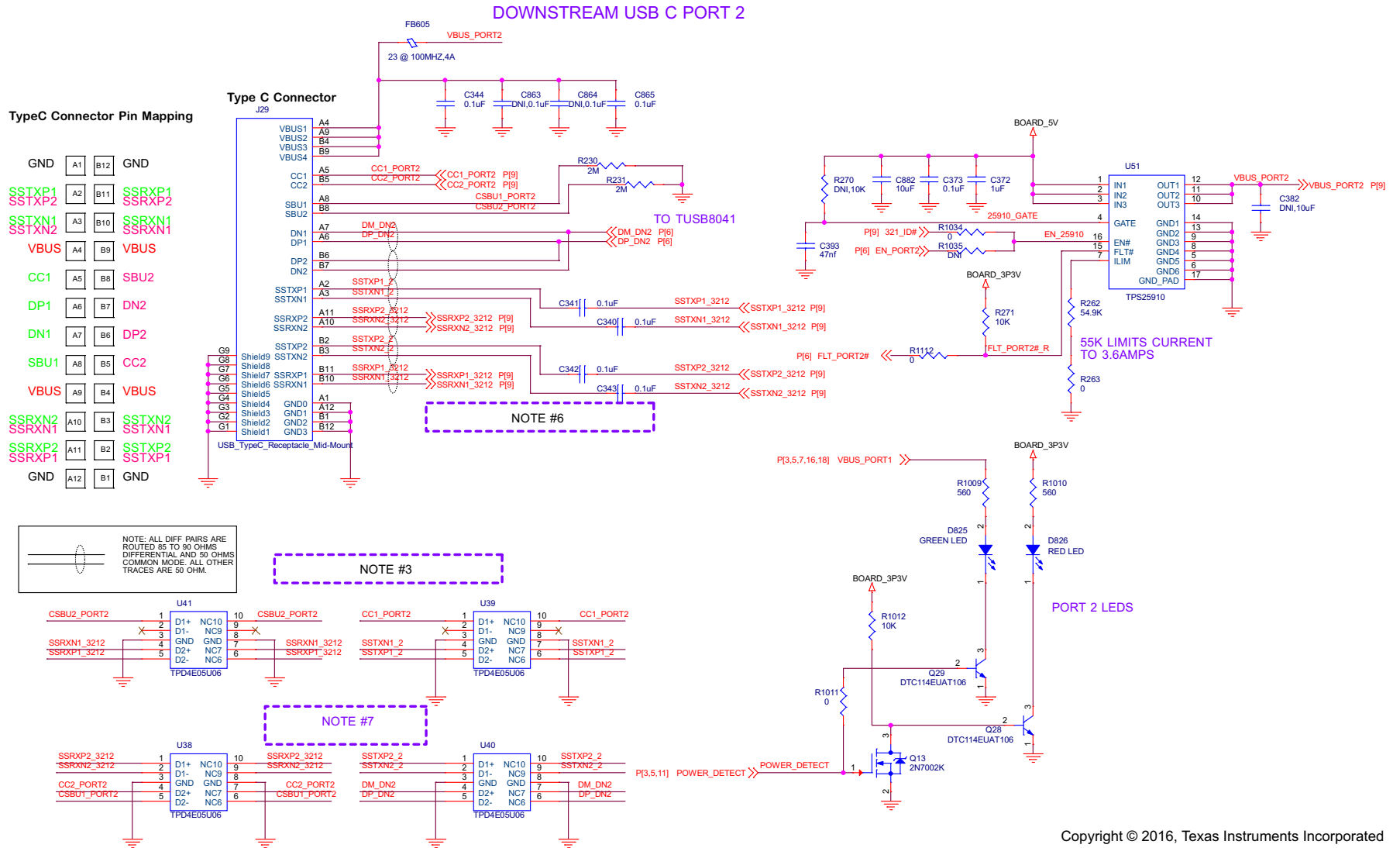
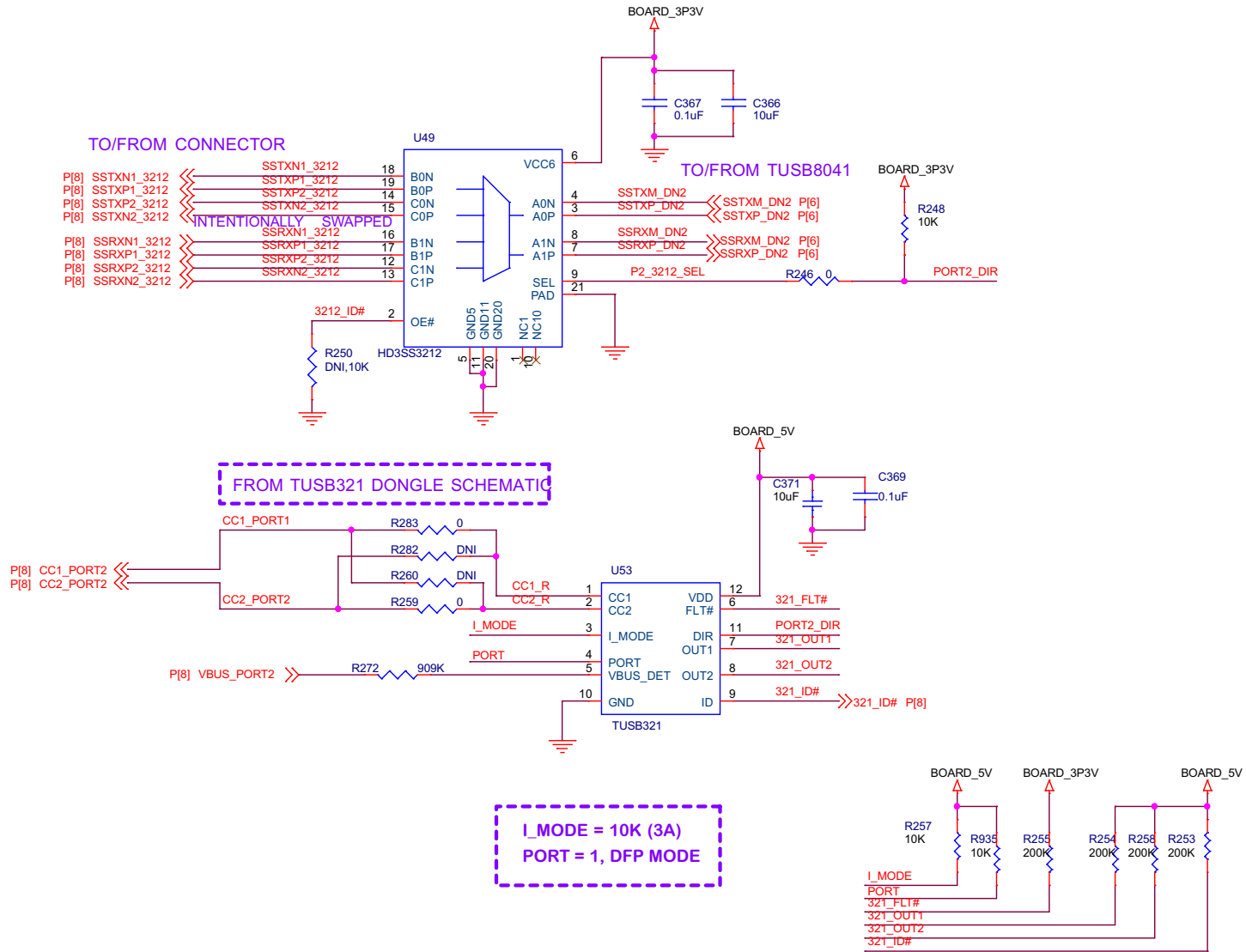

Figure 12. Port 2 Downstream USB Type-C Schematic

Copyright © 2016, Texas Instruments Incorporated

DOWNSTREAM USB C PORT 2



Copyright © 2016, Texas Instruments Incorporated

Figure 13. Port 2 USB Type-C Schematic

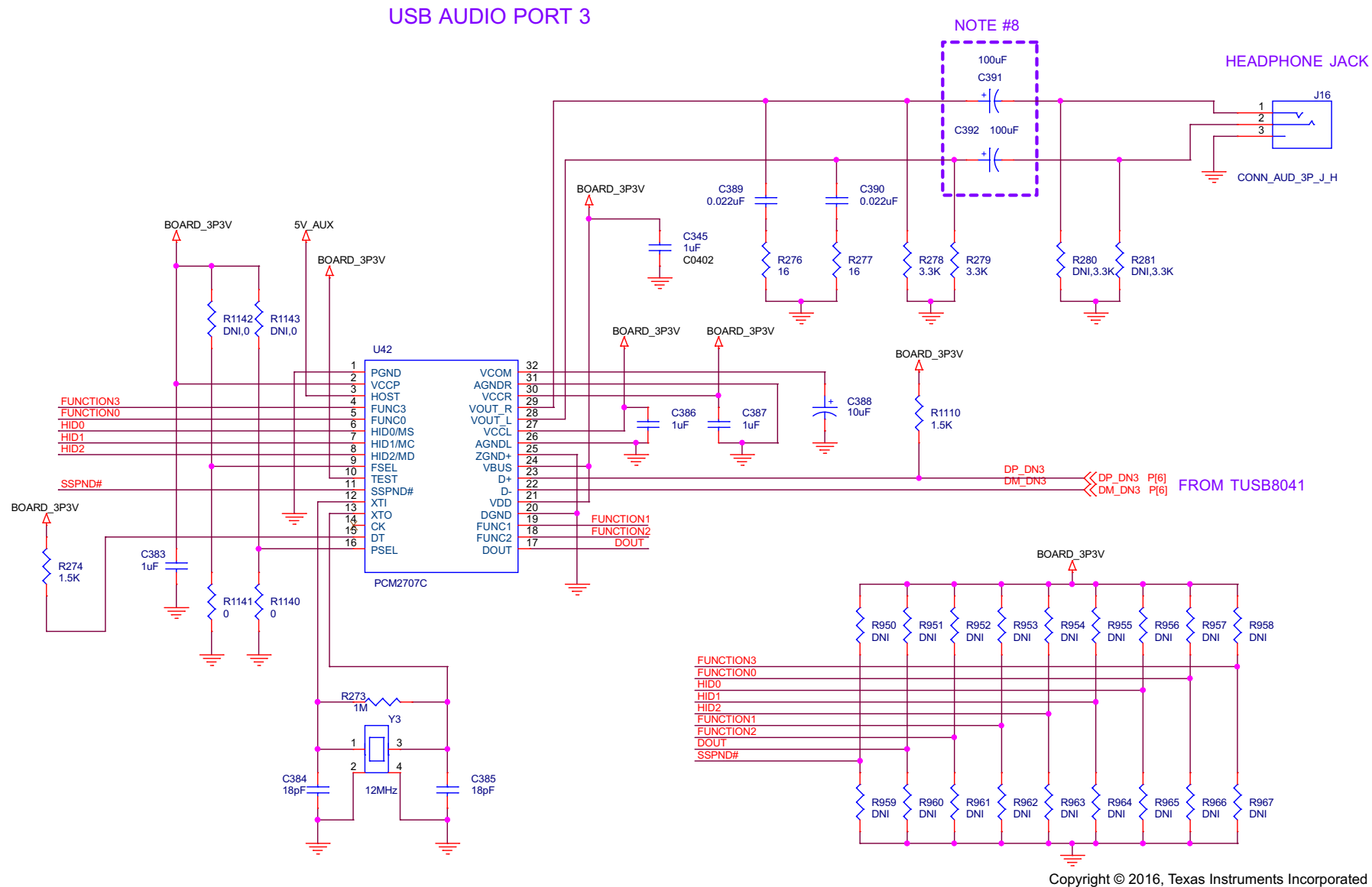
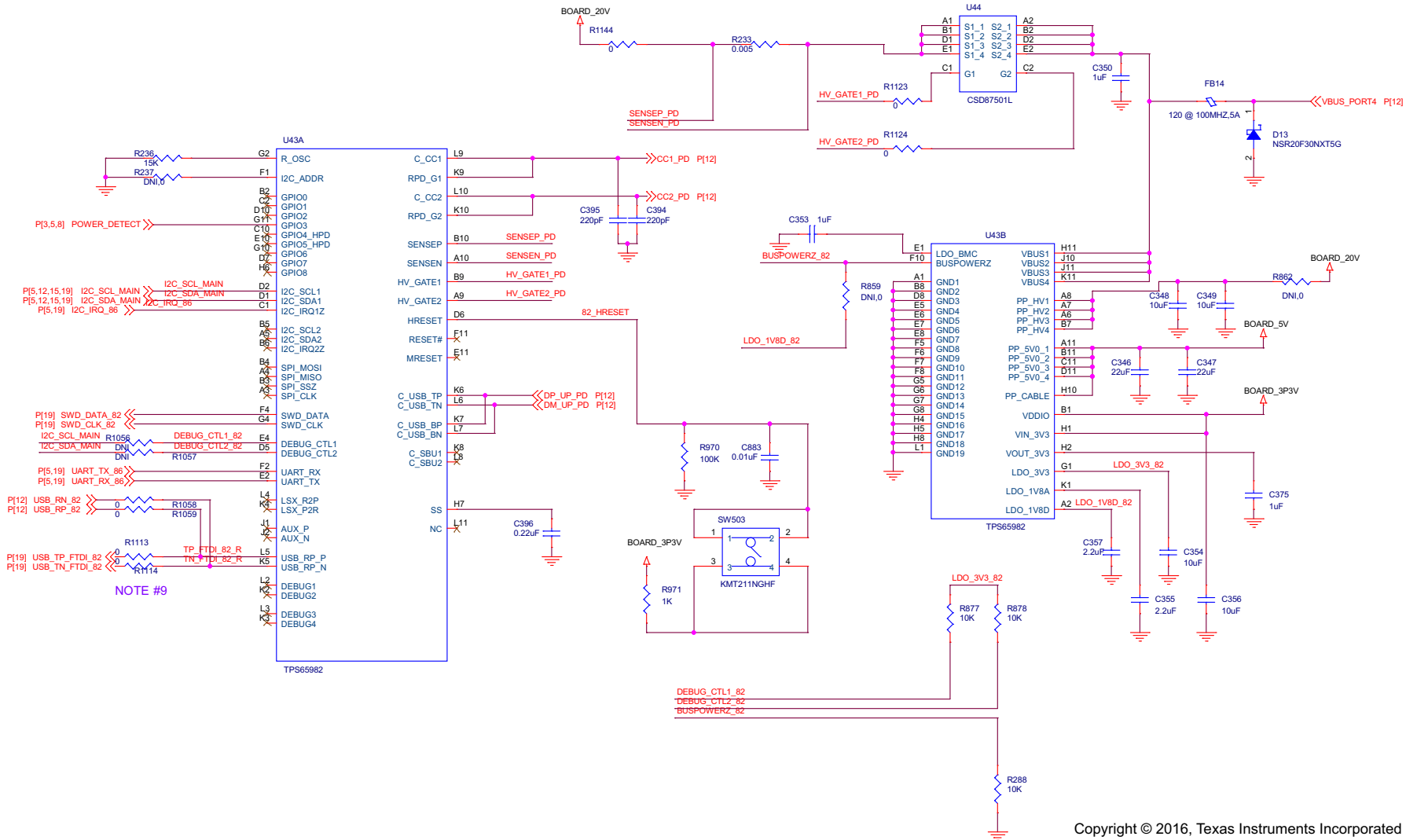

Figure 14. Port 3 USB Audio Schematic

PORT 4 - TPS65982



Copyright © 2016, Texas Instruments Incorporated

Figure 15. Port 4 USB Type-C Charging Schematic

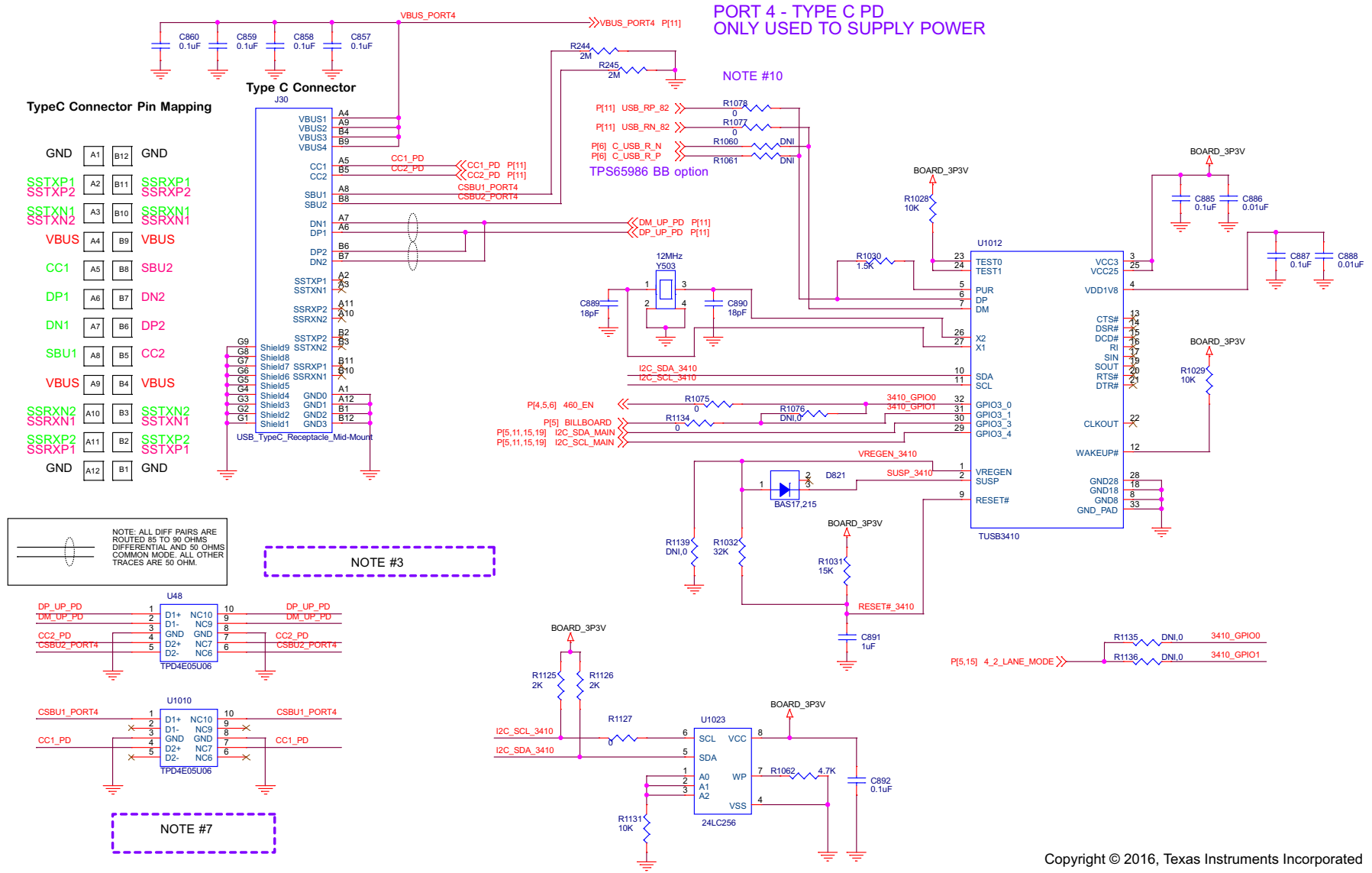

Figure 16. Port 4 USB Type-C Connector Schematic

Copyright © 2016, Texas Instruments Incorporated

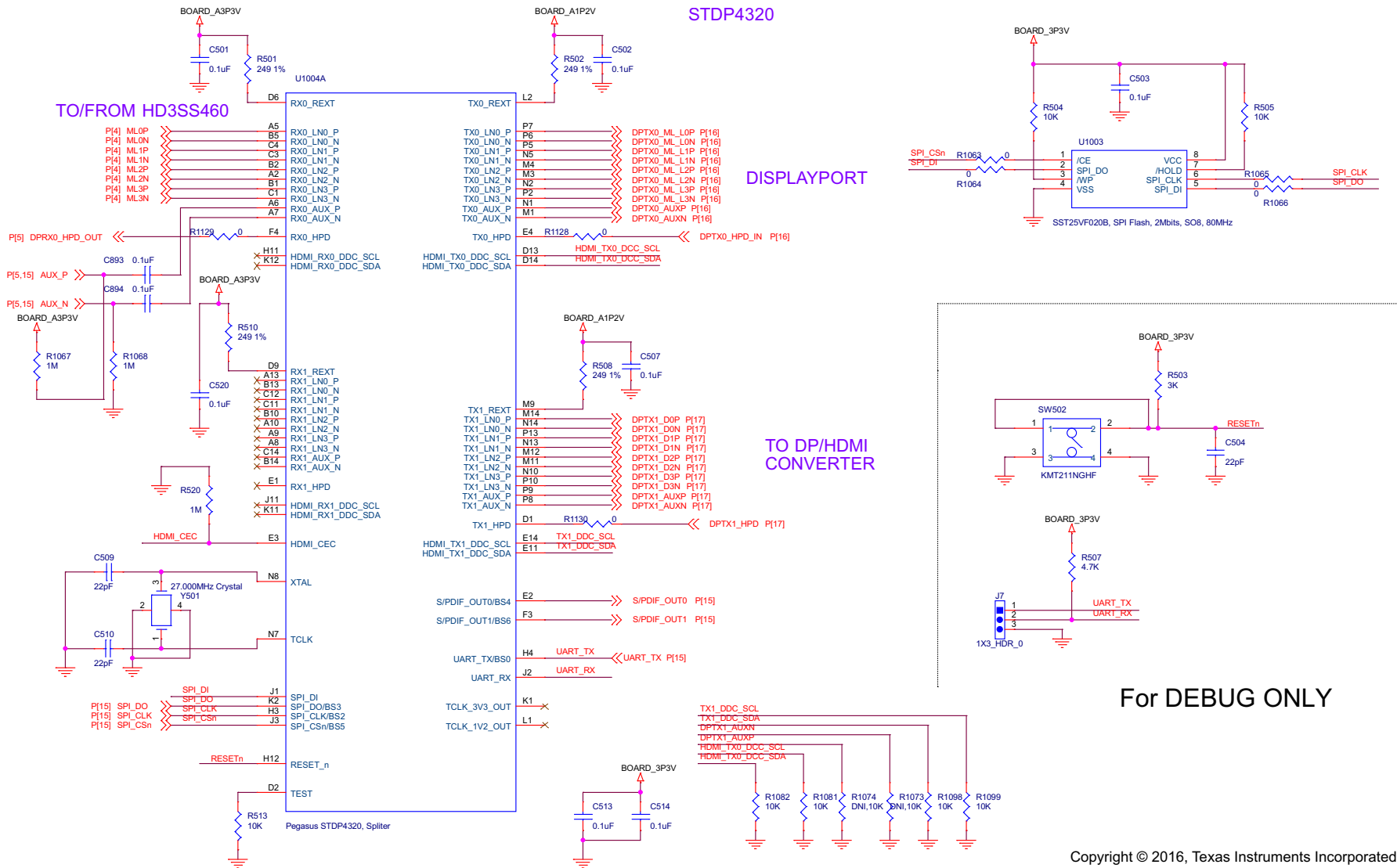
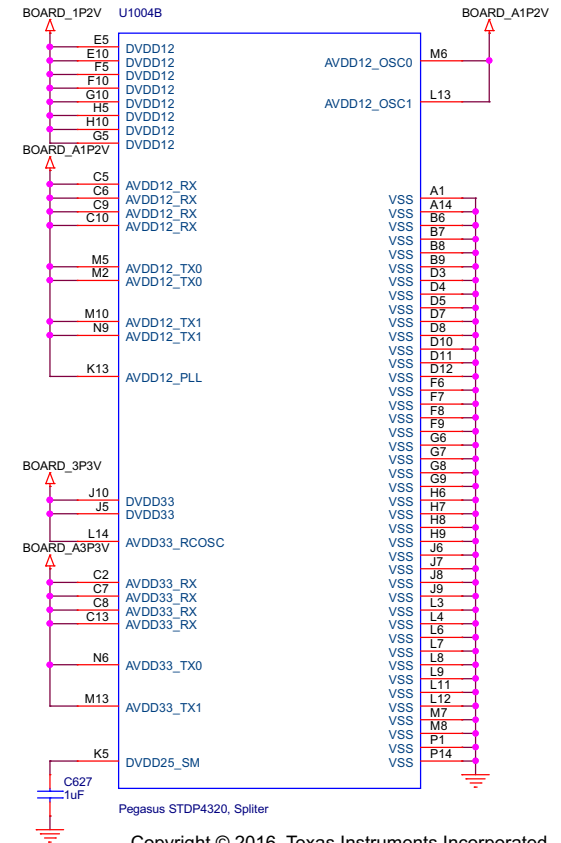
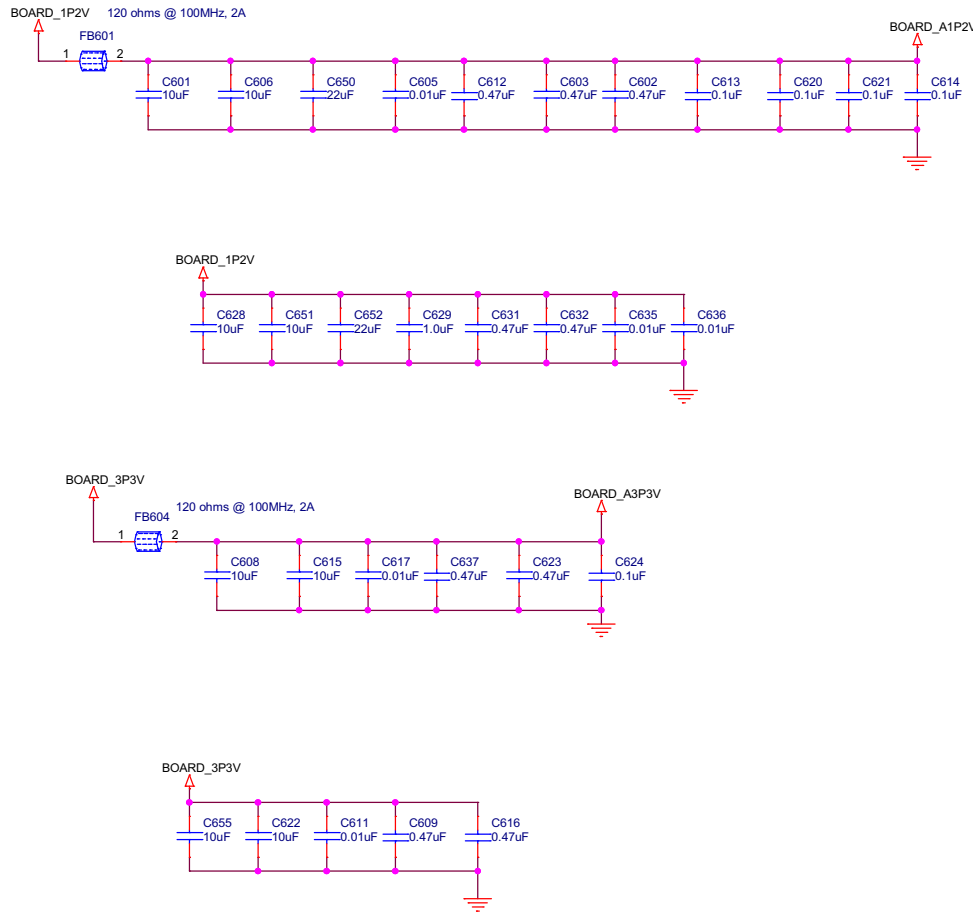

Figure 17. DP4320 Schematic

Copyright © 2016, Texas Instruments Incorporated

STDP4320 POWER



Pegasus STDP4320, Splitter
Copyright © 2016, Texas Instruments Incorporated

Figure 18. DP4320 Power Schematic

STDP4320 BOOTSTRAPS

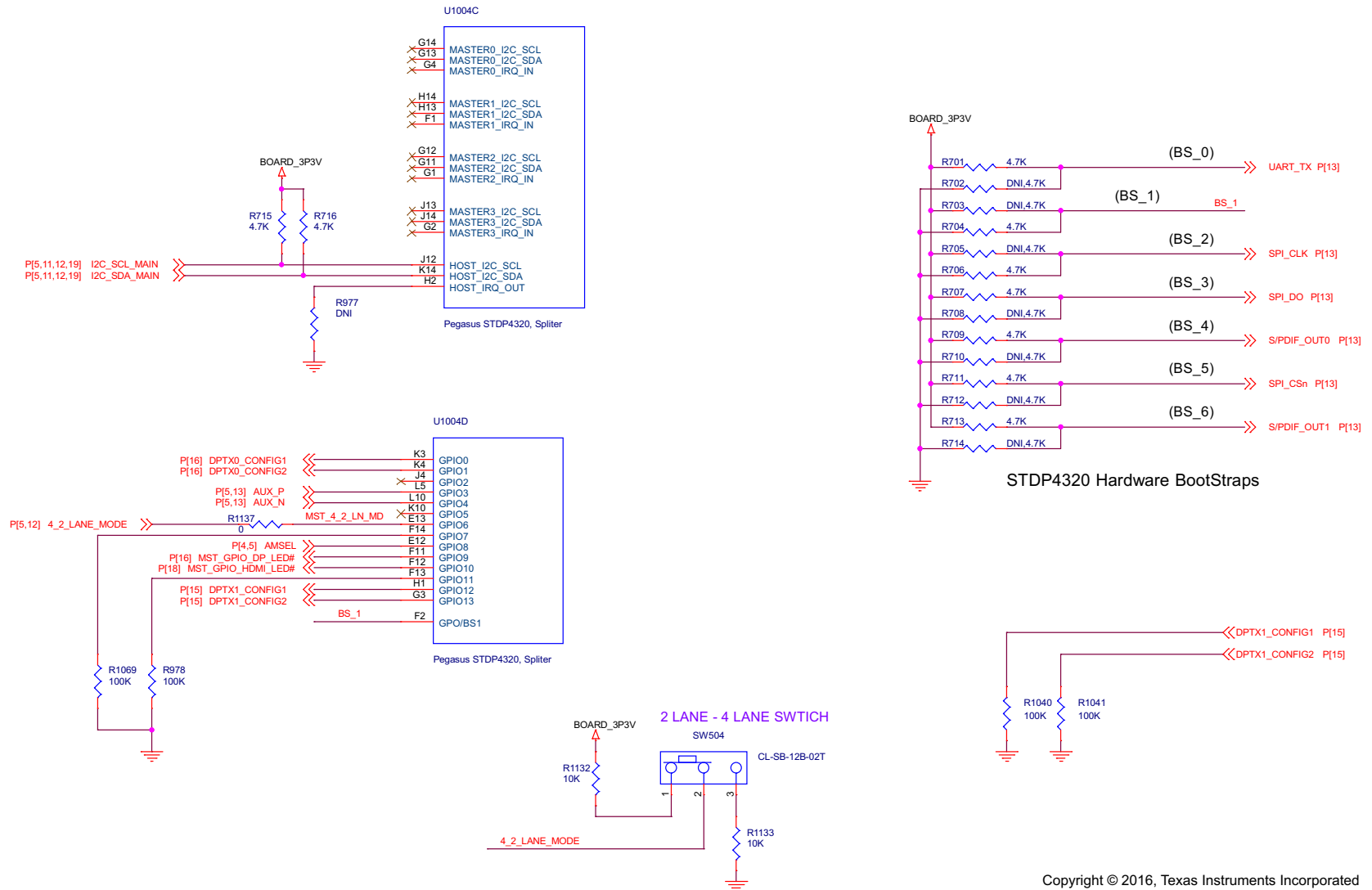

Copyright © 2016, Texas Instruments Incorporated

Figure 19. DP4320 Bootstrap Schematic

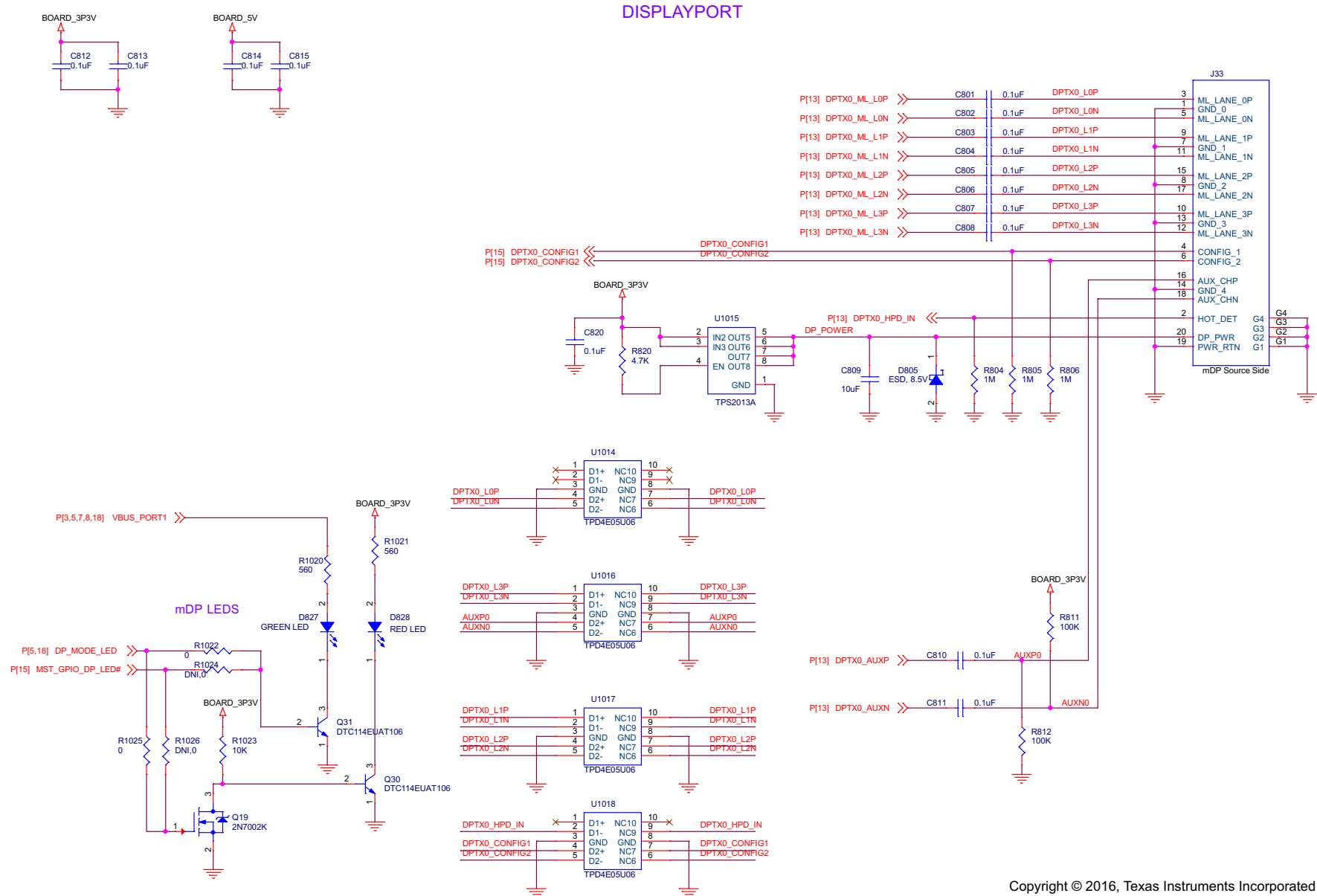

Copyright © 2016, Texas Instruments Incorporated

Figure 20. EVM Display Port Schematic

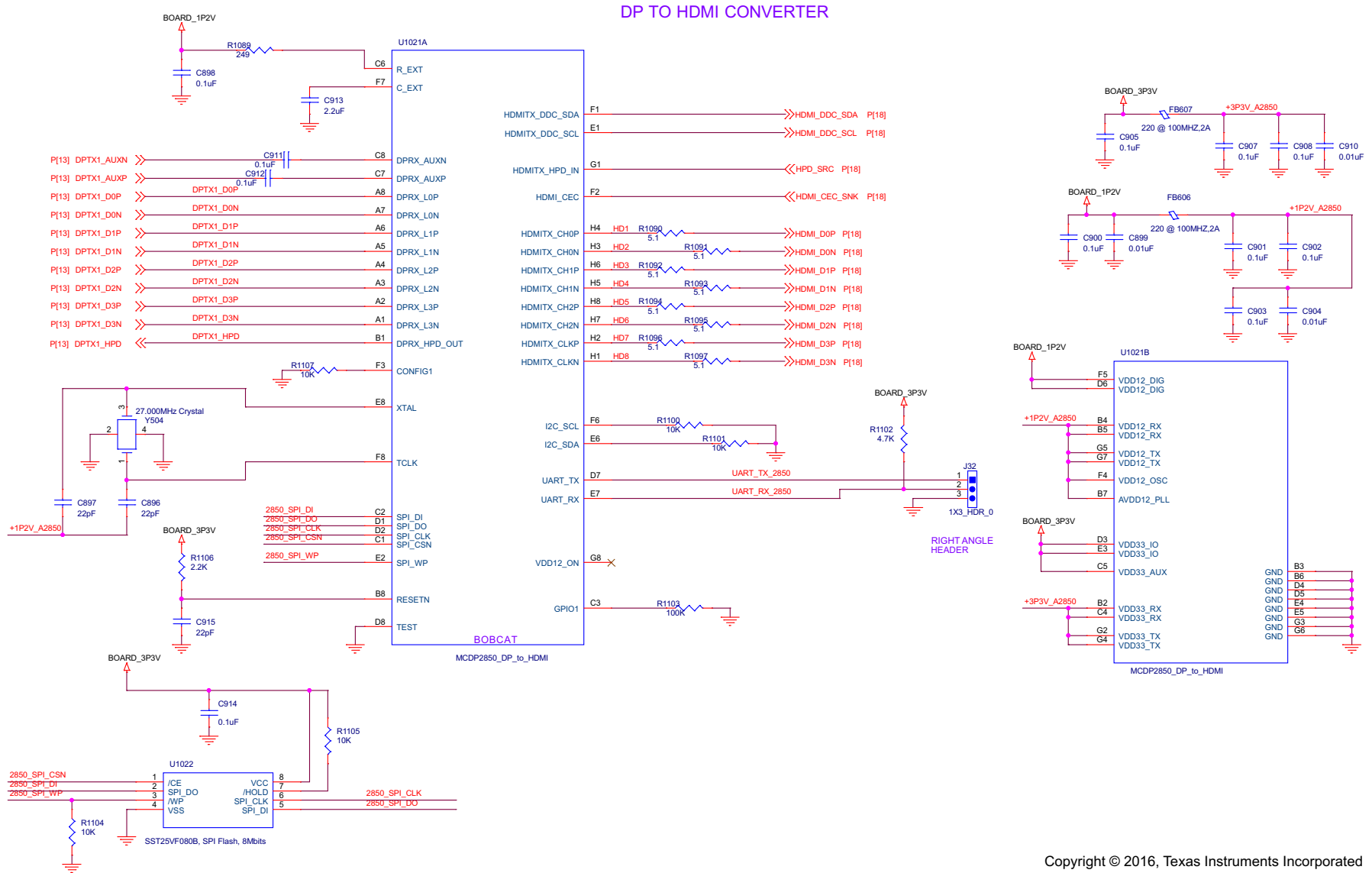

Copyright © 2016, Texas Instruments Incorporated

Figure 21. DP to HDMI Schematic

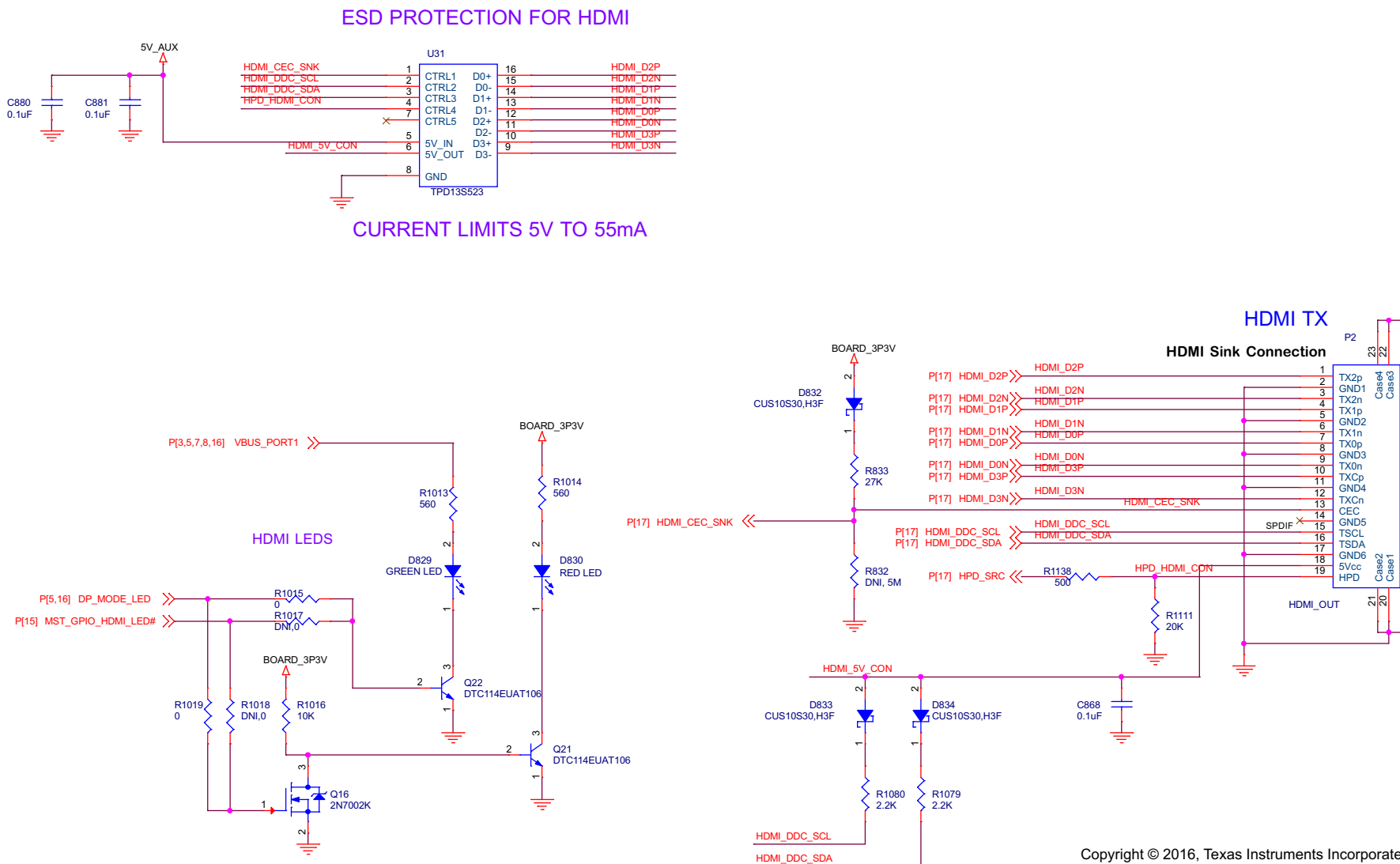
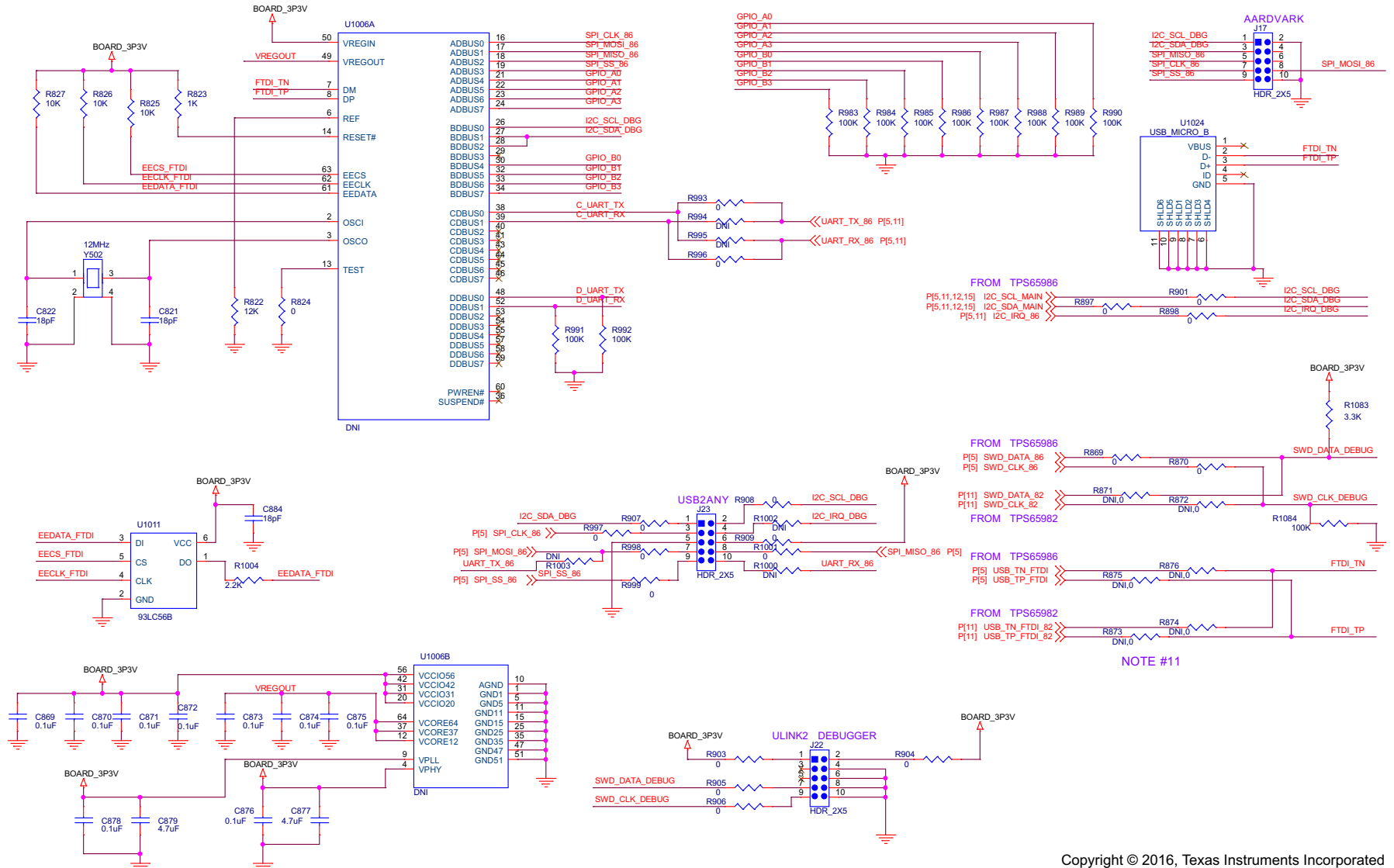

Figure 22. EVM HDMI Connector Schematic

DEBUG BOARD - FTDI - USB - I2C/SPI/UART



Copyright © 2016, Texas Instruments Incorporated

Figure 23. Debug Board Schematic

- 1- PLACE C916 C917 ANY WHERE ON THE BOARD
- 2- KEEP C2, C3, C7, C8 CAPS CLOSE TO CONNECTOR LET RESISTORS SHARE PADS
- 3- KEEP ESD CLOSE TO CONNECTOR
- 4- THESE CONNECTIONS ARE FOR FLOW THROUGH ROUTING
- 5- DP MODE LED PLACE NEAR DP/HDMI
- 6- KEEP C340, C341, C342, C343 CAPS CLOSE TO CONNECTOR LET RESISTORS SHARE PADS
- 7- THESE CONNECTIONS ARE FOR FLOW THROUGH ROUTING
- 8- C291 AND C192 MUST BE 5.4mm TALL
- 9- PAD SHARING R1058 AND R1114, R1059 AND R1113
- 10- Place R1077 and R1078 as close as possible to R1060 and R1061
- 11- PAD SHARING R873 AND R875, R874 AND 876
- 12- Pad sharing with R1060 and R1061 on page 12

Copyright © 2016, Texas Instruments Incorporated

Figure 24. EVM Schematic Fab Notes

Revision History

NOTE: Page numbers for previous revisions may differ from page numbers in the current version.

Changes from A Revision (August 2016) to B Revision	Page
• Changed description of USB Type-C Dock.	2

IMPORTANT NOTICE FOR TI DESIGN INFORMATION AND RESOURCES

Texas Instruments Incorporated ("TI") technical, application or other design advice, services or information, including, but not limited to, reference designs and materials relating to evaluation modules, (collectively, "TI Resources") are intended to assist designers who are developing applications that incorporate TI products; by downloading, accessing or using any particular TI Resource in any way, you (individually or, if you are acting on behalf of a company, your company) agree to use it solely for this purpose and subject to the terms of this Notice.

TI's provision of TI Resources does not expand or otherwise alter TI's applicable published warranties or warranty disclaimers for TI products, and no additional obligations or liabilities arise from TI providing such TI Resources. TI reserves the right to make corrections, enhancements, improvements and other changes to its TI Resources.

You understand and agree that you remain responsible for using your independent analysis, evaluation and judgment in designing your applications and that you have full and exclusive responsibility to assure the safety of your applications and compliance of your applications (and of all TI products used in or for your applications) with all applicable regulations, laws and other applicable requirements. You represent that, with respect to your applications, you have all the necessary expertise to create and implement safeguards that (1) anticipate dangerous consequences of failures, (2) monitor failures and their consequences, and (3) lessen the likelihood of failures that might cause harm and take appropriate actions. You agree that prior to using or distributing any applications that include TI products, you will thoroughly test such applications and the functionality of such TI products as used in such applications. TI has not conducted any testing other than that specifically described in the published documentation for a particular TI Resource.

You are authorized to use, copy and modify any individual TI Resource only in connection with the development of applications that include the TI product(s) identified in such TI Resource. NO OTHER LICENSE, EXPRESS OR IMPLIED, BY ESTOPPEL OR OTHERWISE TO ANY OTHER TI INTELLECTUAL PROPERTY RIGHT, AND NO LICENSE TO ANY TECHNOLOGY OR INTELLECTUAL PROPERTY RIGHT OF TI OR ANY THIRD PARTY IS GRANTED HEREIN, including but not limited to any patent right, copyright, mask work right, or other intellectual property right relating to any combination, machine, or process in which TI products or services are used. Information regarding or referencing third-party products or services does not constitute a license to use such products or services, or a warranty or endorsement thereof. Use of TI Resources may require a license from a third party under the patents or other intellectual property of the third party, or a license from TI under the patents or other intellectual property of TI.

TI RESOURCES ARE PROVIDED "AS IS" AND WITH ALL FAULTS. TI DISCLAIMS ALL OTHER WARRANTIES OR REPRESENTATIONS, EXPRESS OR IMPLIED, REGARDING TI RESOURCES OR USE THEREOF, INCLUDING BUT NOT LIMITED TO ACCURACY OR COMPLETENESS, TITLE, ANY EPIDEMIC FAILURE WARRANTY AND ANY IMPLIED WARRANTIES OF MERCHANTABILITY, FITNESS FOR A PARTICULAR PURPOSE, AND NON-INFRINGEMENT OF ANY THIRD PARTY INTELLECTUAL PROPERTY RIGHTS.

TI SHALL NOT BE LIABLE FOR AND SHALL NOT DEFEND OR INDEMNIFY YOU AGAINST ANY CLAIM, INCLUDING BUT NOT LIMITED TO ANY INFRINGEMENT CLAIM THAT RELATES TO OR IS BASED ON ANY COMBINATION OF PRODUCTS EVEN IF DESCRIBED IN TI RESOURCES OR OTHERWISE. IN NO EVENT SHALL TI BE LIABLE FOR ANY ACTUAL, DIRECT, SPECIAL, COLLATERAL, INDIRECT, PUNITIVE, INCIDENTAL, CONSEQUENTIAL OR EXEMPLARY DAMAGES IN CONNECTION WITH OR ARISING OUT OF TI RESOURCES OR USE THEREOF, AND REGARDLESS OF WHETHER TI HAS BEEN ADVISED OF THE POSSIBILITY OF SUCH DAMAGES.

You agree to fully indemnify TI and its representatives against any damages, costs, losses, and/or liabilities arising out of your non-compliance with the terms and provisions of this Notice.

This Notice applies to TI Resources. Additional terms apply to the use and purchase of certain types of materials, TI products and services. These include; without limitation, TI's standard terms for semiconductor products (<http://www.ti.com/sc/docs/stdterms.htm>), [evaluation modules](#), and [samples](http://www.ti.com/sc/docs/sampterm.htm) (<http://www.ti.com/sc/docs/sampterm.htm>).

Mailing Address: Texas Instruments, Post Office Box 655303, Dallas, Texas 75265
Copyright © 2018, Texas Instruments Incorporated