

ZL6100EVAL2Z Dual Channel Evaluation Board

AN2041

REV.0.00

Sep 11, 2009

Description

The ZL6100 is an integrated mixed-signal power conversion and management IC that combines an efficient step-down DC/DC converter with key power and thermal management functions in a single package. The ZL6100 incorporates current sharing and adaptive efficiency-optimization algorithms to provide a flexible, efficient power IC building block.

The ZL6100EVAL2Z platform is a 6-layer board with two power rails. One rail is a single phase, 30A power rail. The other rail is a dual phase, 60A power rail demonstrating the current sharing capability of the ZL6100.

A USB to SMBus adapter board can be used to connect the eval board to a PC. The PMBus command set is accessed by using the Zilker Labs PowerNavigator™ evaluation software from a PC running Microsoft Windows.

Features

- 30A Single-phase and 60A Dual-phase Rails
- Optimized for Efficiency
- Configurable Through SMBus
- Onboard Enable Switch
- Power Good Indicators

Target Specifications

- $V_{IN} = 12V$
- $V_{OUT1} = 1.8V/60A$ max
- $V_{OUT2} = 1.5V/30A$ max
- $f_{SW} = 300kHz$
- Efficiency: 90% at 50% load
- Output Ripple: $\pm 1.5\%$
- Dynamic response: $\pm 3\%$
(50%-70%-50% load step, $di/dt = 2.5A/\mu s$)
- Board Temperature: $+25^{\circ}C$

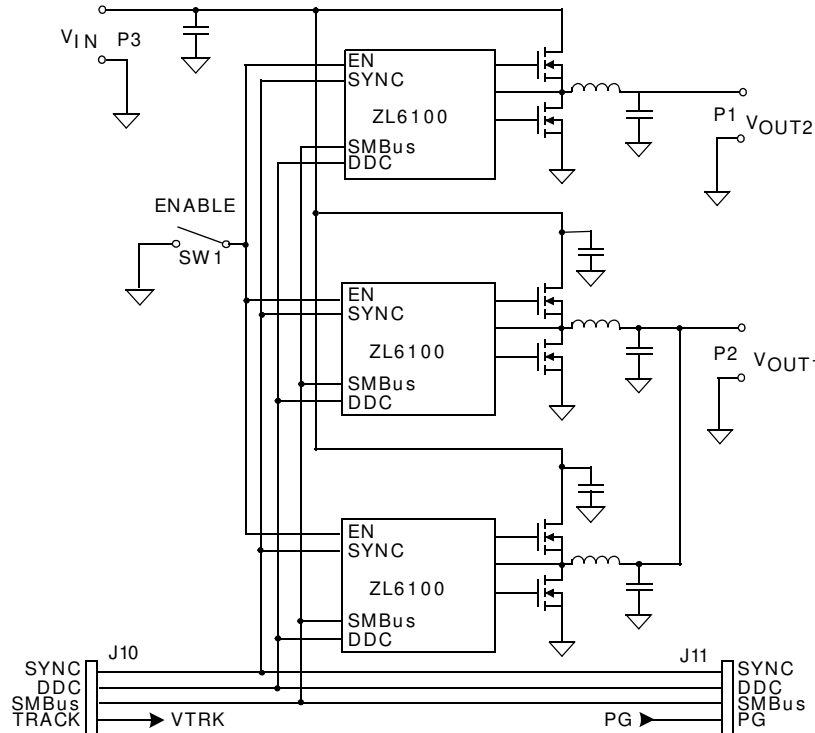

FIGURE 1. ZL6100EVAL2Z BLOCK DIAGRAM

Functional Description

The ZL6100EVAL2Z provides all circuitry required to demonstrate the features of the ZL6100. The ZL6100EVAL2Z has a functionally-optimized ZL6100 circuit layout that allows efficient operation up to the maximum output current. Power and load connections are provided through plug-in sockets.

All features of the ZL6100 such as current sharing, soft-start delay and ramp times, supply sequencing, voltage tracking, and voltage margining are available on this evaluation board. For voltage tracking, the board is set up for the single phase rail (V_{OUT2}) to track the dual phase rail (V_{OUT1}). Contact the Zilker Labs sales office for configuring the board for other tracking combinations.

Figure 1 shows a functional block diagram of the ZL6100EVAL2Z board. The SMBus address is selectable through a jumper on the top side of the board. All power to the board (VIN and I²C bus) must be removed before changing the jumpers.

The hardware enable function is controlled by a toggle switch on the ZL6100EVAL2Z board. The power good (PG) LEDs indicate the correct state of PG when external power is applied to the ZL6100EVAL2Z board. (Note: If a USB board is connected to the ZL6100EVAL2Z and no power is applied to the board, the PG LEDs will turn on even though the power rails are not enabled.) The right angle headers at opposite ends of the board are for connecting a USB to SMBus adapter board or for daisy chaining of multiple evaluation boards.

Figures 2 and 3 show the two phases of the 60A circuit. Figure 4 shows the single phase operational circuit. The circuit consists of the ZL6100 IC with its minimal component count to realize a 30A buck converter. The board layout has been optimized for thermal performance.

Figure 5 is the Interface and Figure 9 SMBus address selection circuitry.

Operation

PMBus Operation

The ZL6100 utilizes the PMBus protocol. The PMBus functionality can be controlled via USB from a PC running the PowerNavigator evaluation software in a Windows XP or Windows 2000/NT operating system.

Install the ZL6100EVAL2Z software using the CD included in the ZL6100EVAL2Z kit.

For board operation, connect the included USB-to-SMBus adapter board to J10 of the ZL6100EVAL2Z board. Connect the desired load and an appropriate power supply to the input and connect the included USB cable to the PC running the PowerNavigator evaluation software. Place the ENABLE switch in "DISABLE" and turn on the power.

The evaluation software allows modification of all ZL6100 PMBus parameters. Each of the ZL6100 devices have

been pre-configured as described in this document, but the user may modify the operating parameters through the eval software or by loading a predefined scenario from a configuration file.

Use the mouse-over pop-ups for PowerNavigator help. Refer to Zilker Labs application note AN2033 "PMBus™ Command Set DDC Products", Intersil Corporation, 2009 for PMBus details.

The ENABLE switch can then be moved to "ENABLE" and the ZL6100EVAL2Z board can be tested. Alternately, the PMBus ON-OFF CONFIG and OPERATION commands may be used.

Quick Start Guide

Stand Alone Operation

1. Set ENABLE switch to "DISABLE"
2. Apply load to VOUT+/VOUT- for each channel
3. Connect power supply to VIN+/VIN- (supply turned off)
4. Turn power supply on
5. Set ENABLE switch to "ENABLE"
6. Monitor ZL6100EVAL2Z board operation using an oscilloscope

USB (PMBus) Operation

1. Set ENABLE switch to "DISABLE"
2. Apply load to VOUT+/VOUT- for each channel
3. Connect power supply to VIN+/VIN- (supply turned off)
4. Turn power supply on
5. Insert the Zilker Labs Eval Kit CD
6. Connect USB to SMBus adapter board to J10 of ZL6100EVAL2Z
7. Connect supplied USB cable from computer to USB to SMBus adapter board
 - a) Upon first-time connection, the Found New Hardware Wizard will appear.
 - b) Windows XP users: Select 'No' at prompt to search the Internet for drivers.
 - c) Follow the steps on the screen to install the drivers from the CD.
8. Install the PowerNavigator evaluation software by running setup.exe from the PowerNavigator_installer folder on the CD.
9. Set ENABLE switch on EVB to "ENABLE"
10. Monitor and configure the ZL6100EVAL2Z board using PMBus commands in the evaluation software
11. Test the ZL6100EVAL2Z operation using an oscilloscope and the evaluation software.

Board Schematics

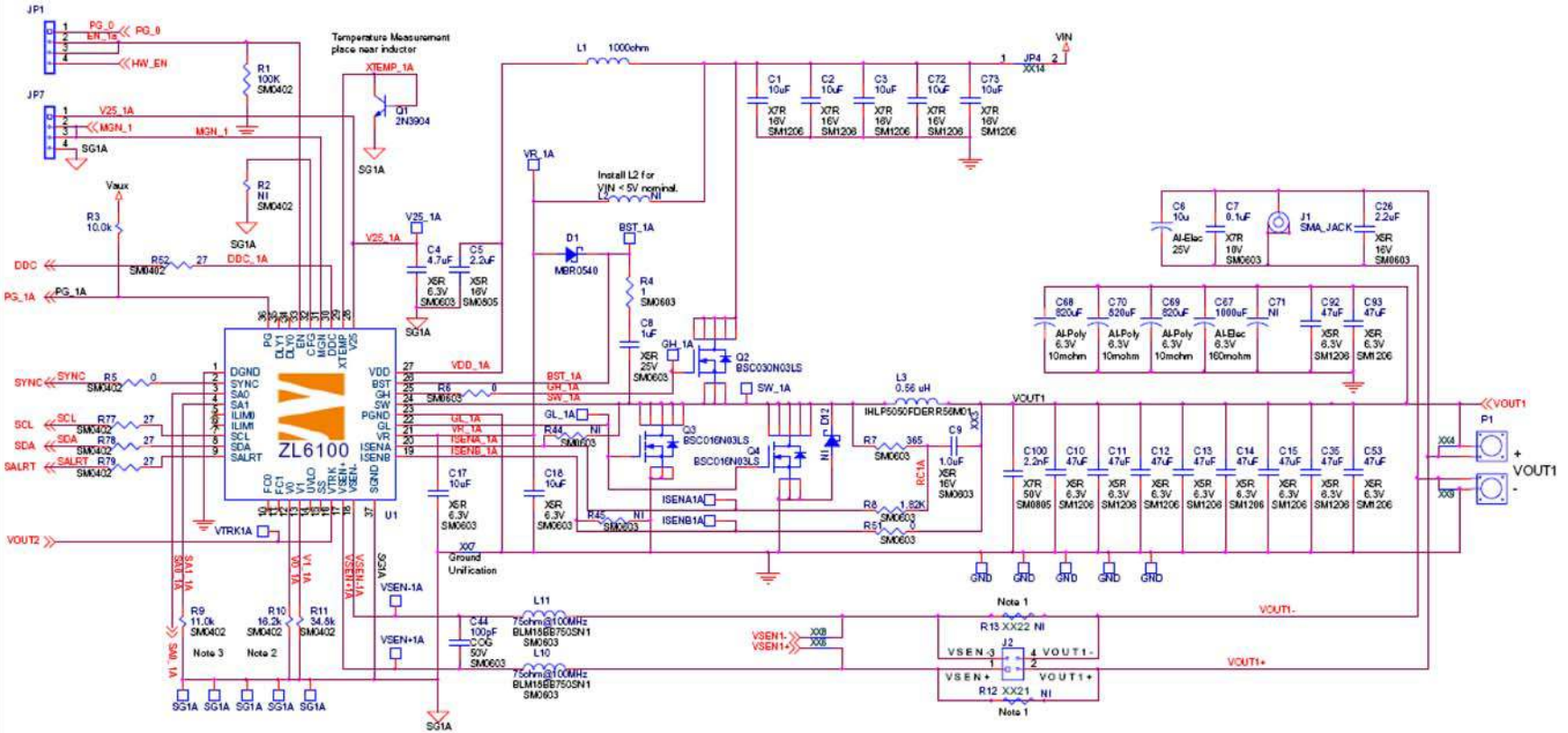

FIGURE 2. ZL6100EVAL2Z 60A CURRENT SHARING RAIL (PHASE A) CIRCUIT



Board Schematics (Continued)

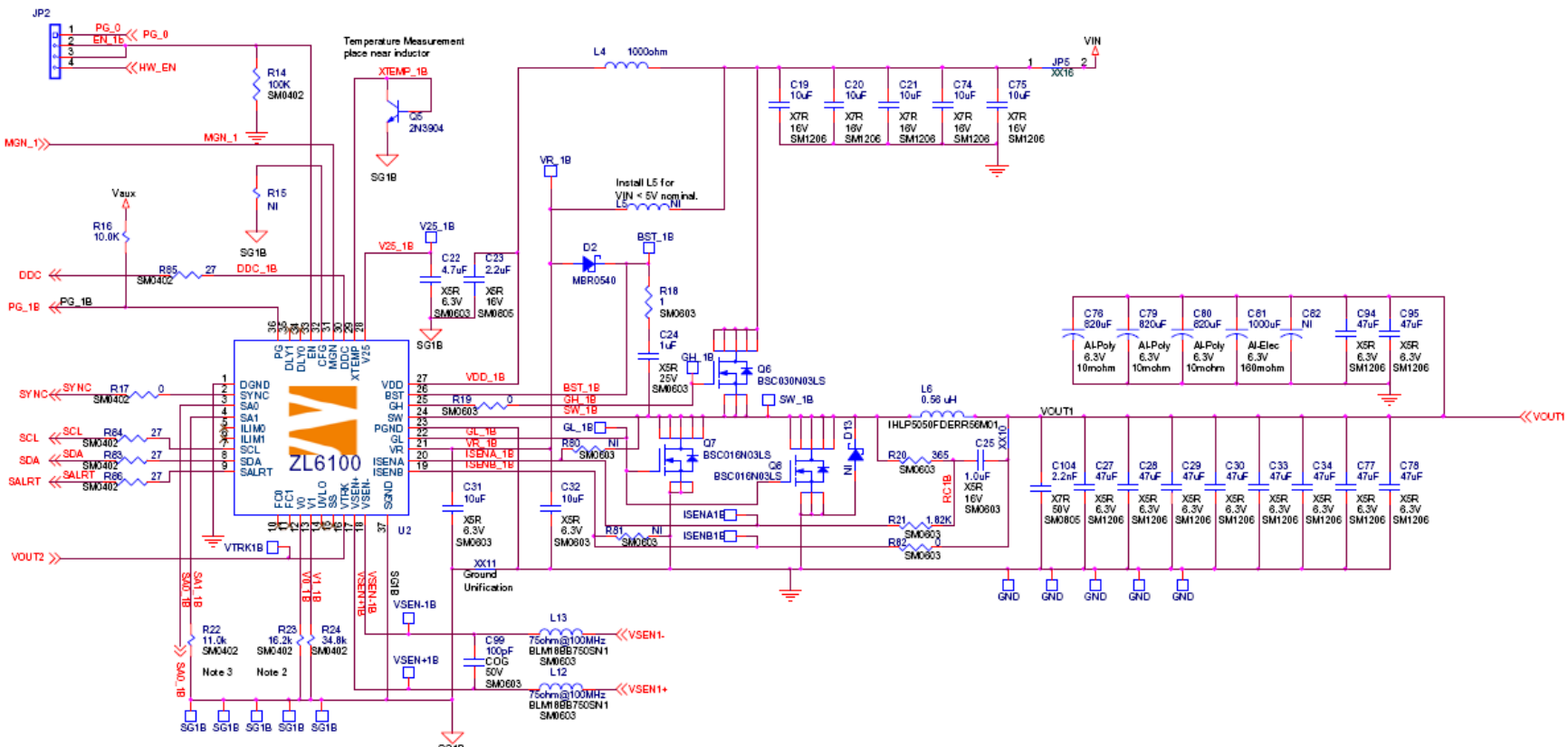

FIGURE 3. ZL6100EVAL2Z 60A CURRENT SHARING RAIL (PHASE B) CIRCUIT



Board Schematics (Continued)

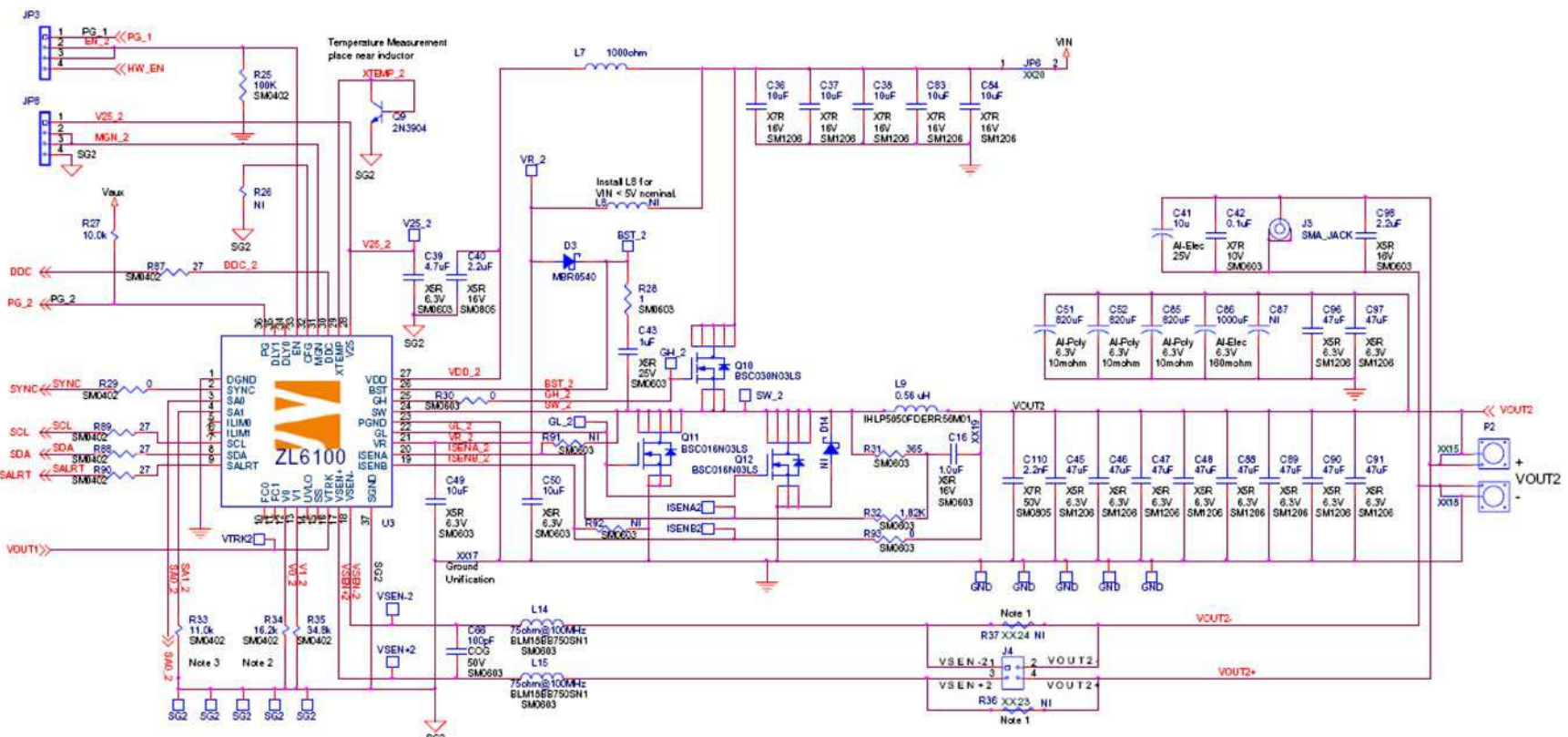

FIGURE 4. ZL6100EVAL2Z 30A SINGLE PHASE RAIL CIRCUIT

Board Schematics (Continued)

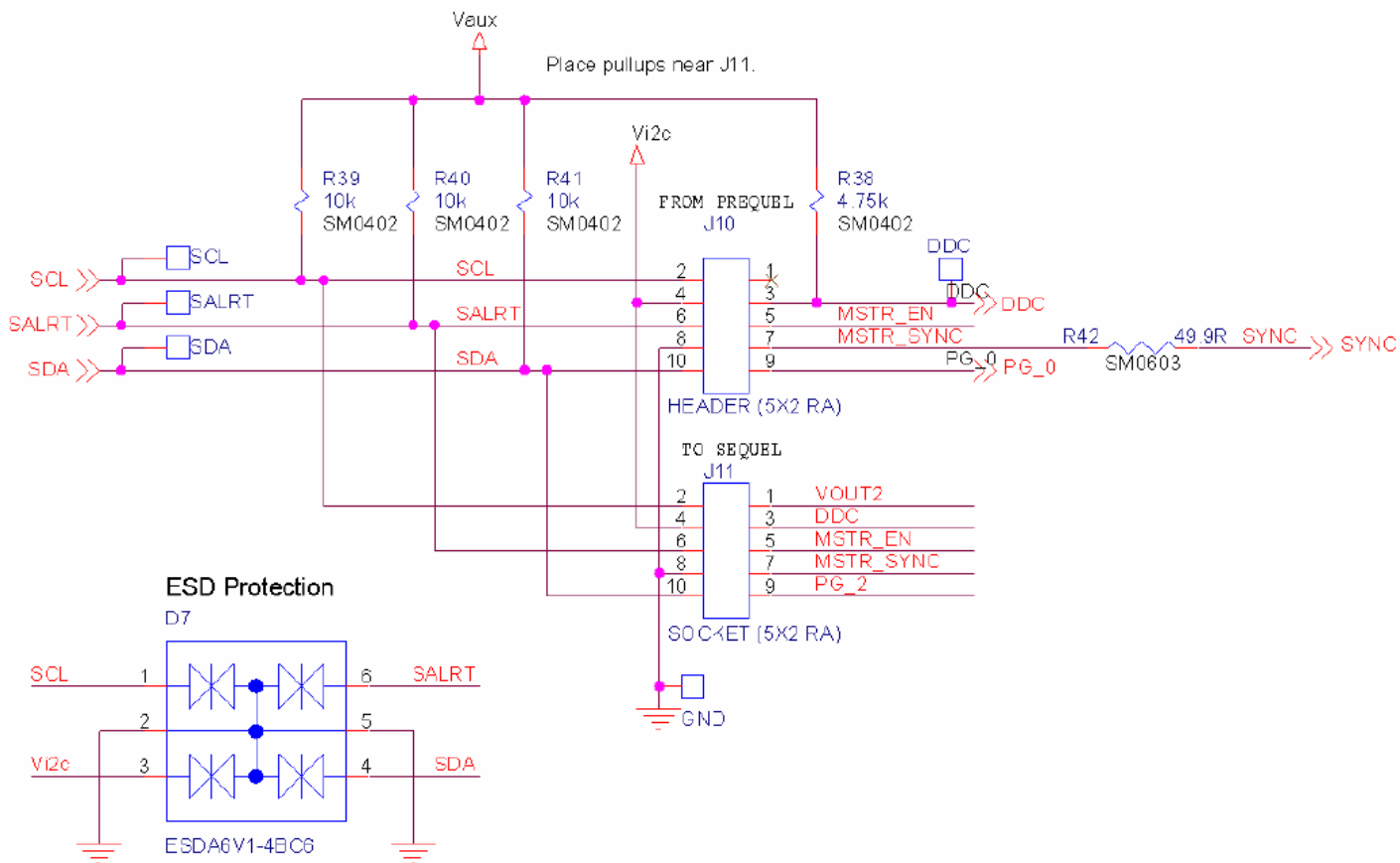

FIGURE 5. ZL6100EVAL2Z INTERFACE CIRCUITRY

Board Schematics (Continued)

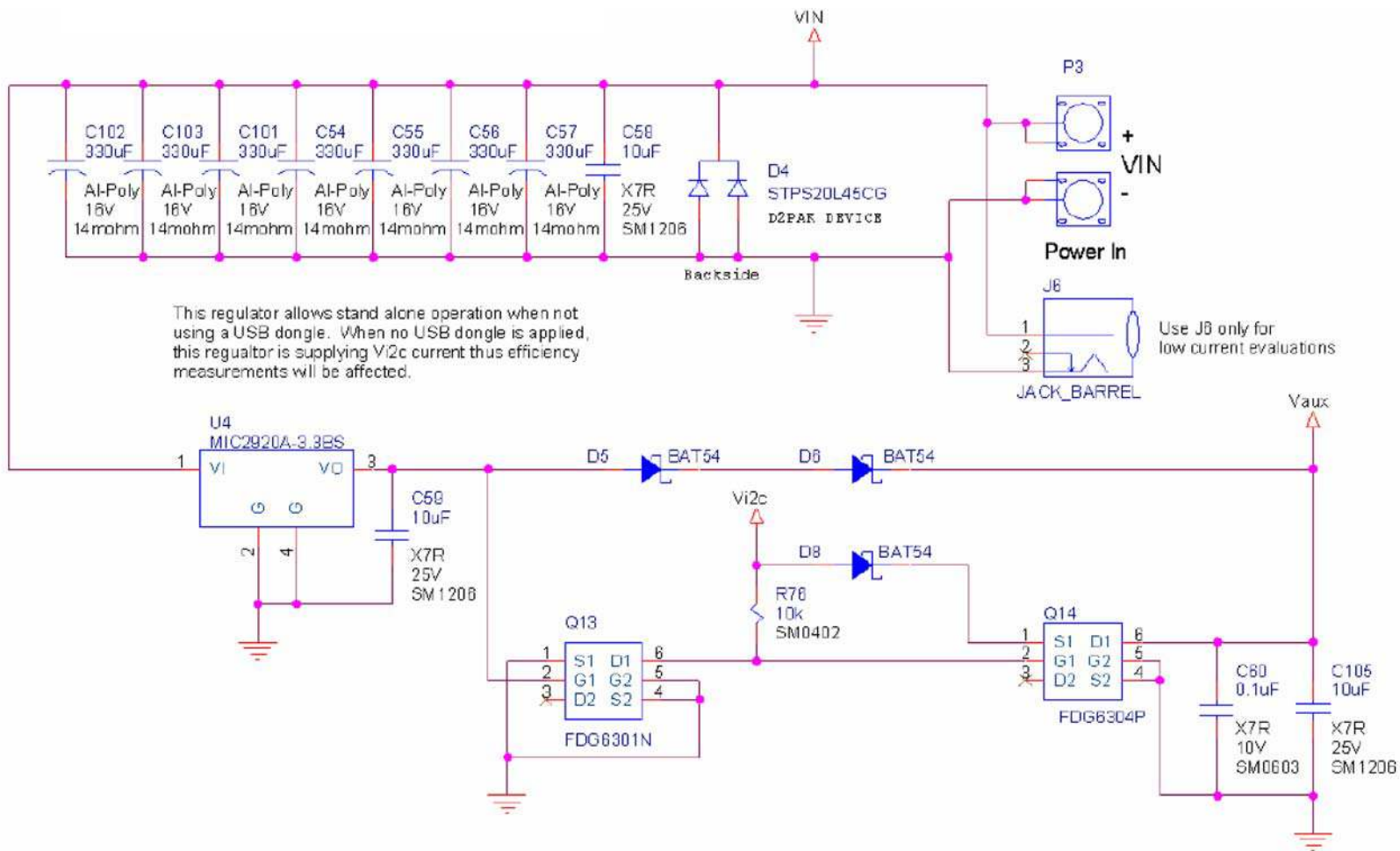

FIGURE 6. POWER-IN CIRCUIT

Board Schematics (Continued)

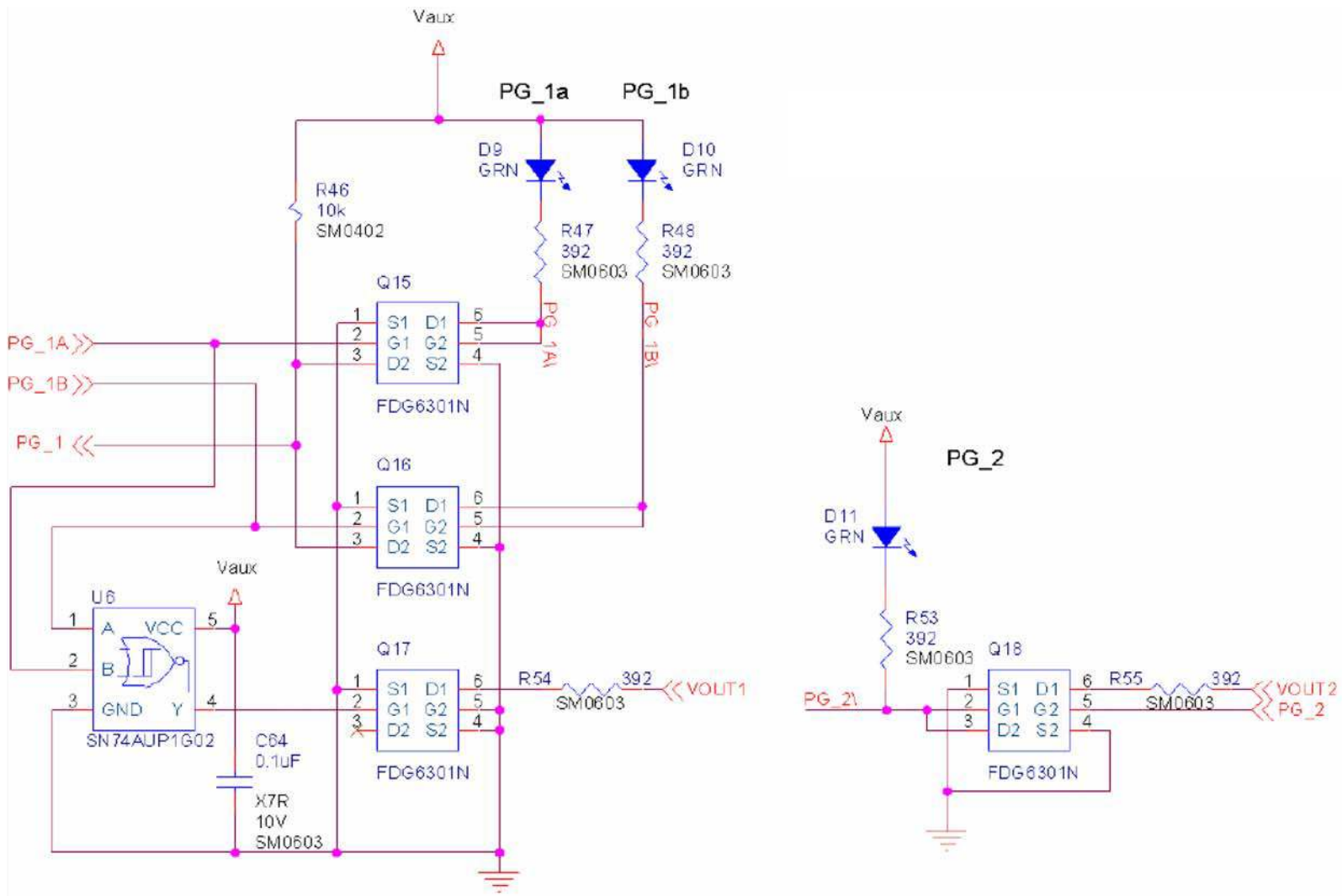

FIGURE 7. PG LED CIRCUITRY

Board Schematics (Continued)

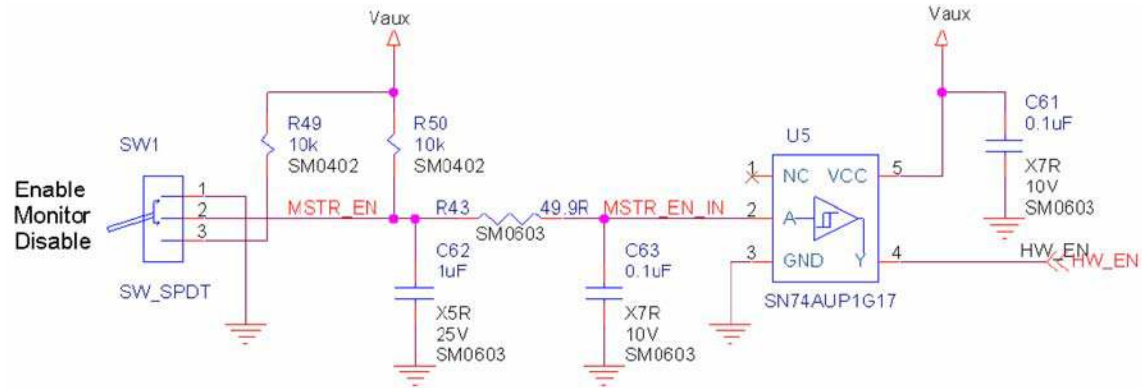

FIGURE 8. ENABLE SWITCH DEBOUNCE CIRCUIT

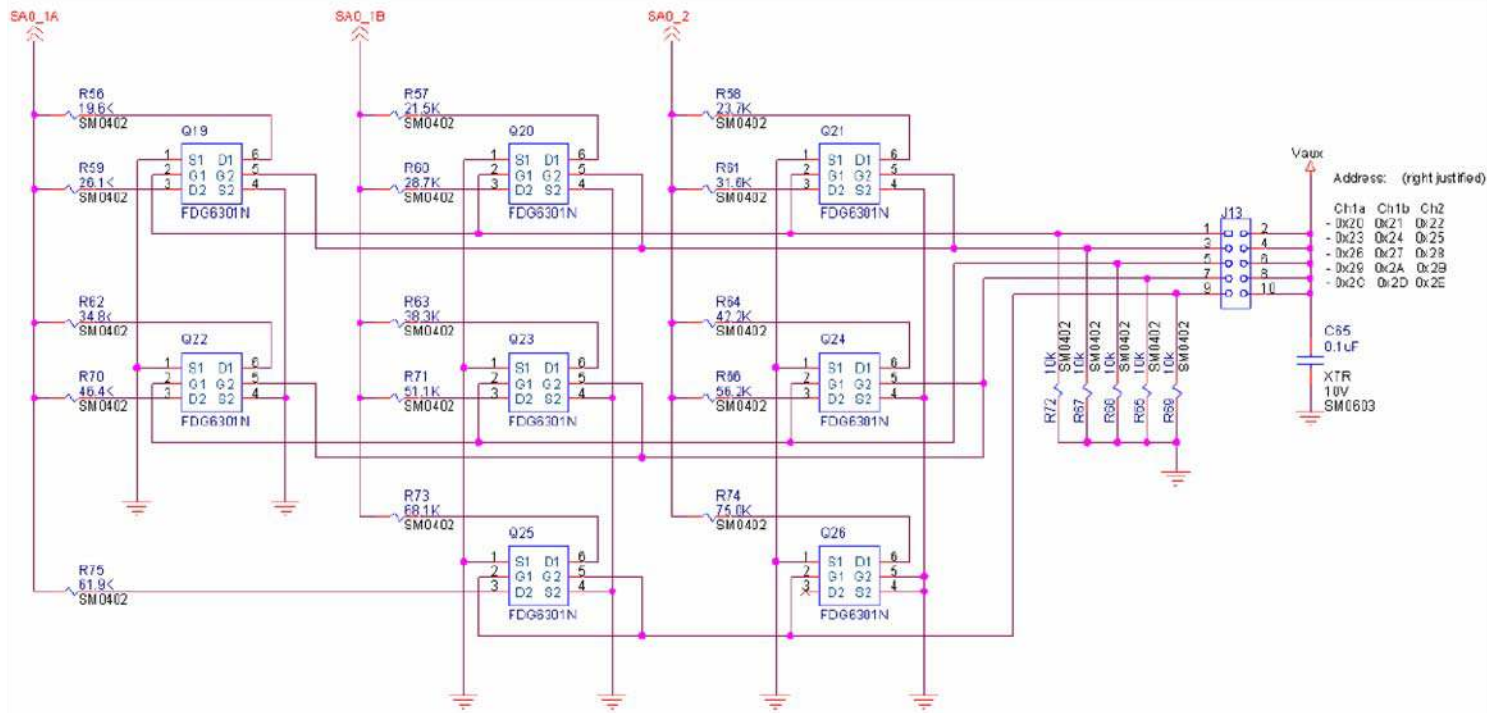

FIGURE 9. ADDRESS SELECTION CIRCUITRY

Board Layout – 6 Layers

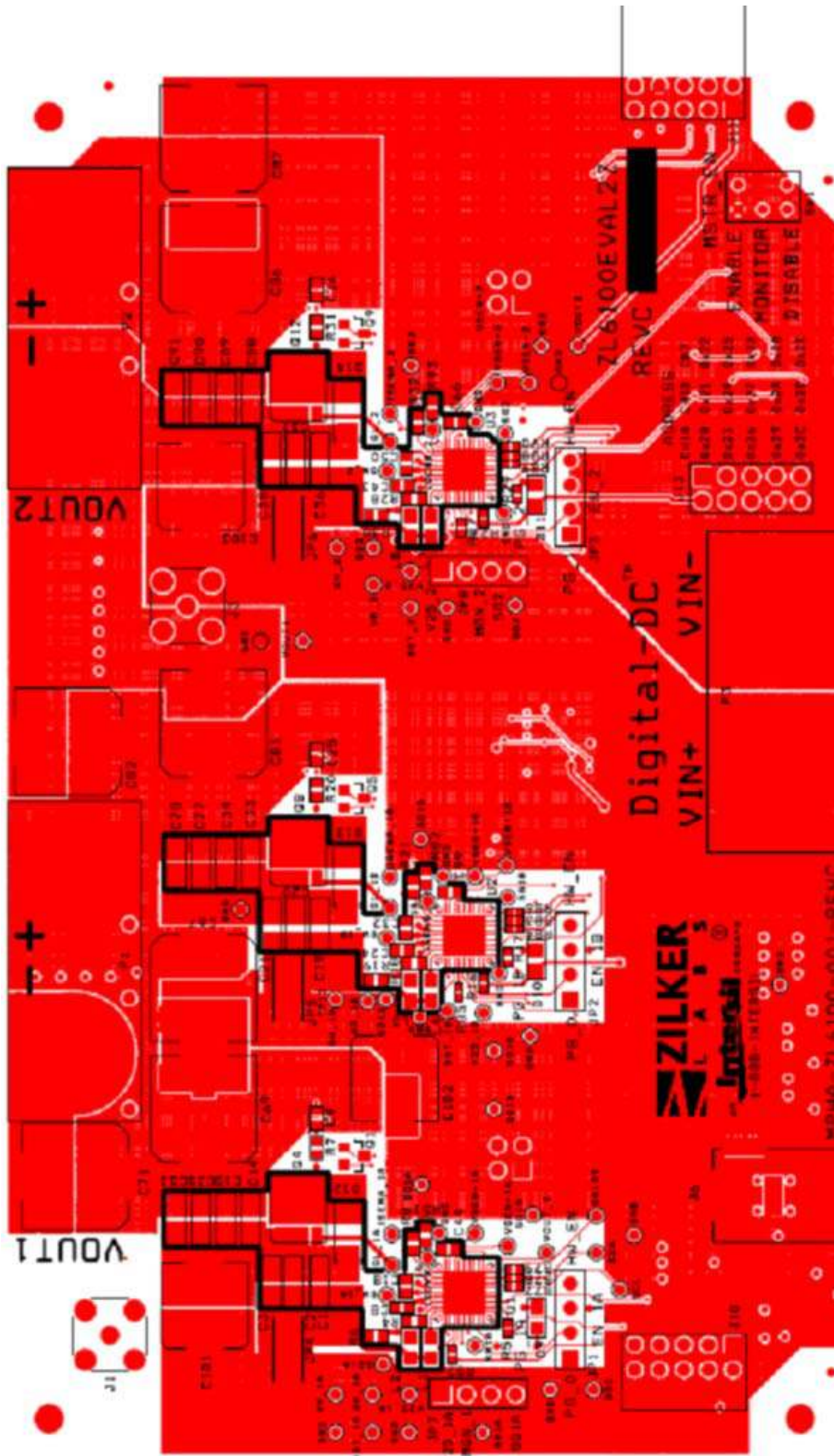

FIGURE 10. PCB – TOP LAYER

Board Layout – 6 Layers (Continued)

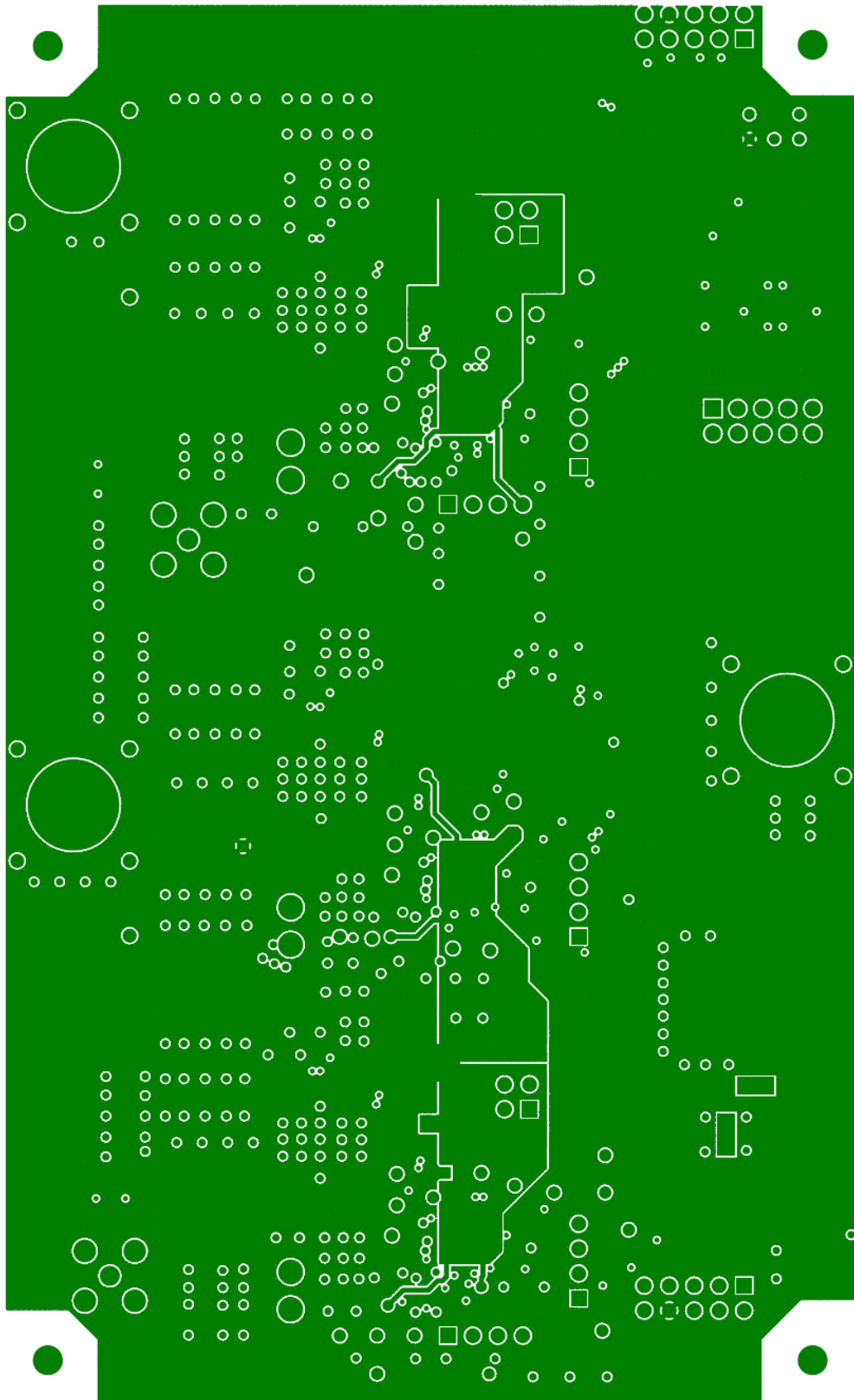

FIGURE 11. PCB – INNER LAYER 1 (VIEWED FROM TOP)

Board Layout – 6 Layers (Continued)

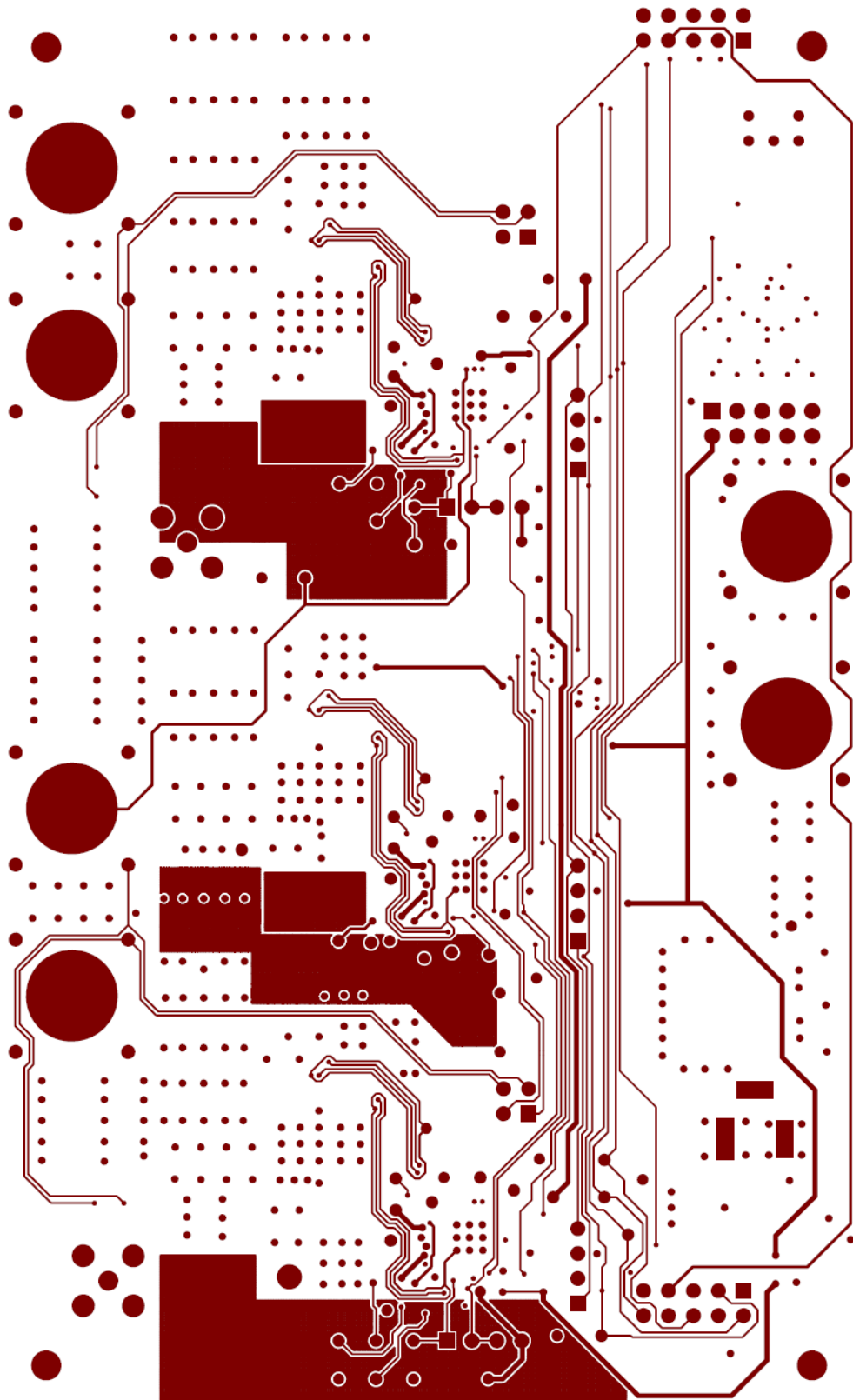

FIGURE 12. PCB – INNER LAYER 2 (VIEWED FROM TOP)

Board Layout – 6 Layers (Continued)

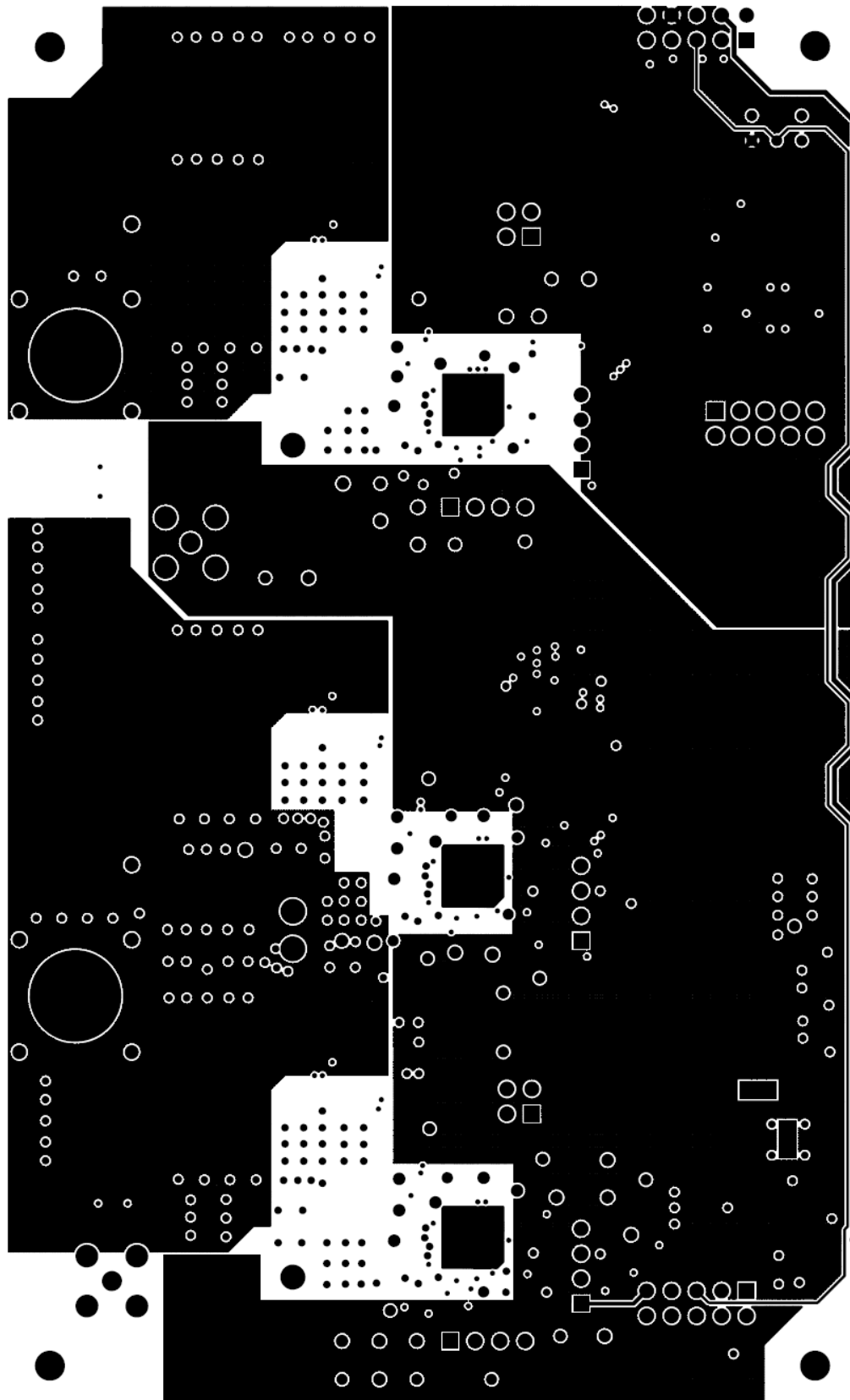

FIGURE 13. INNER LAYER 3 (VIEWED FROM TOP)

Board Layout – 6 Layers (Continued)

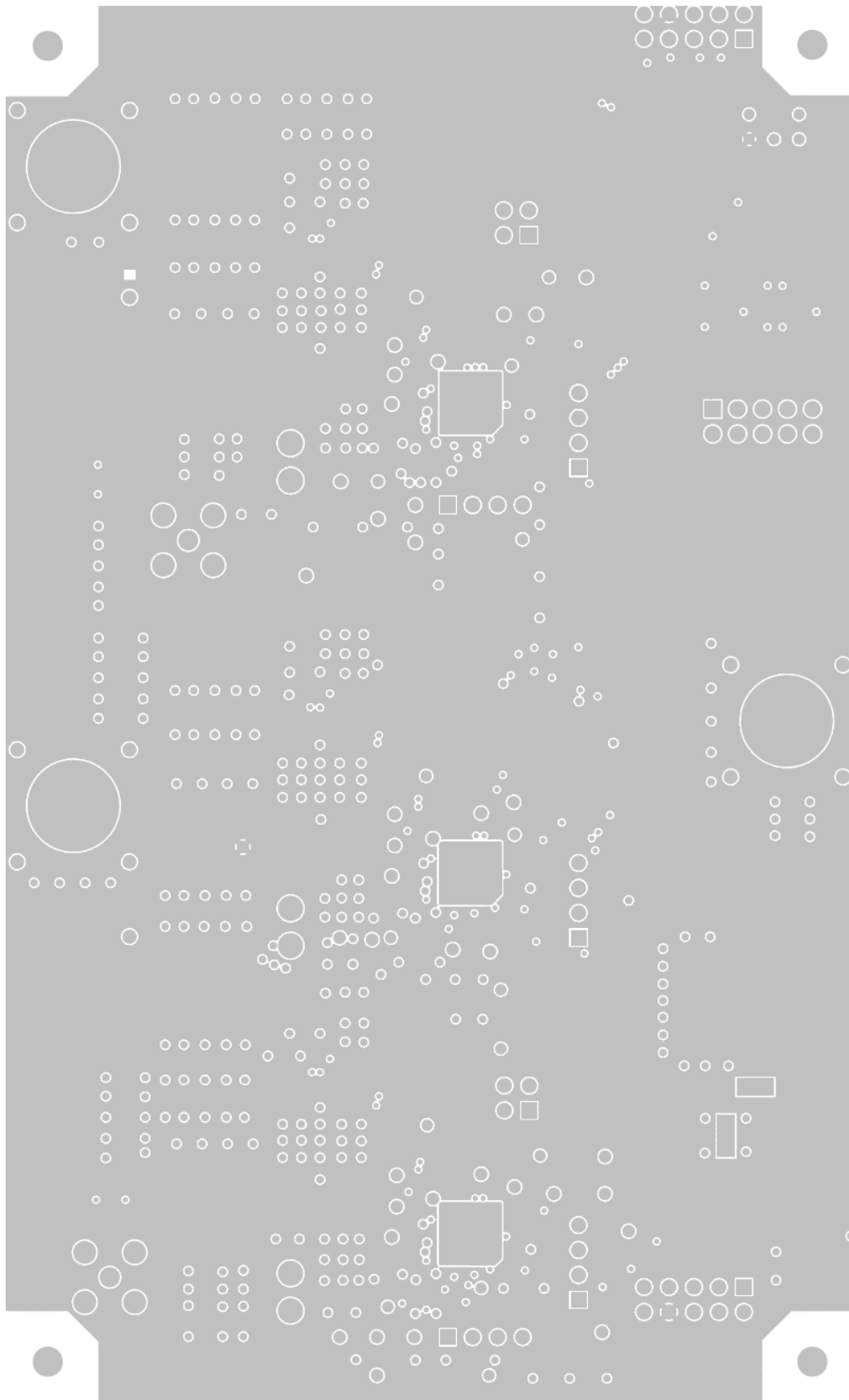

FIGURE 14. INNER LAYER 4 (VIEWED FROM TOP)

Board Layout – 6 Layers (Continued)

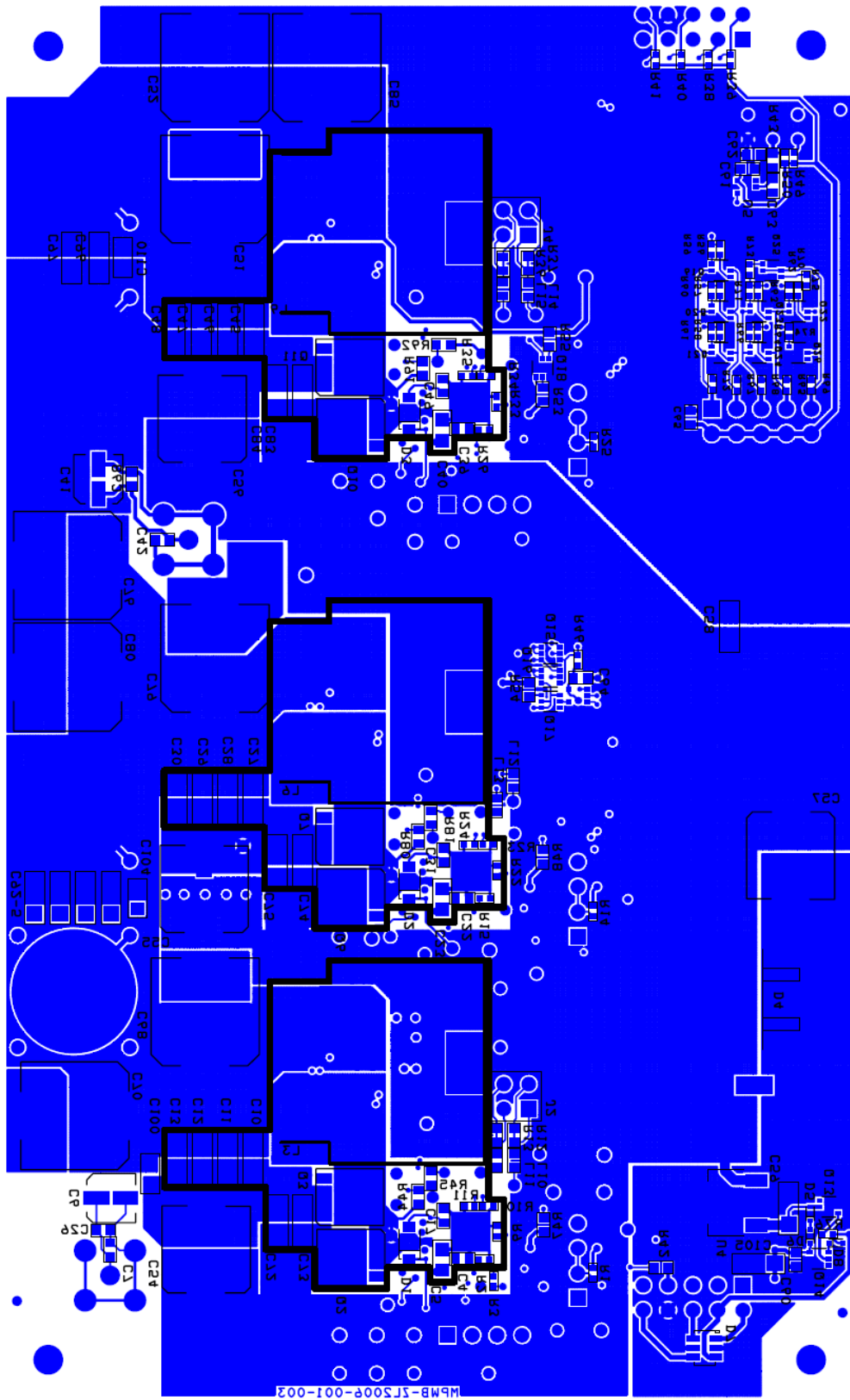

FIGURE 15. PCB – BOTTOM LAYER (VIEWED FROM TOP)

Board Layout – 6 Layers (Continued)

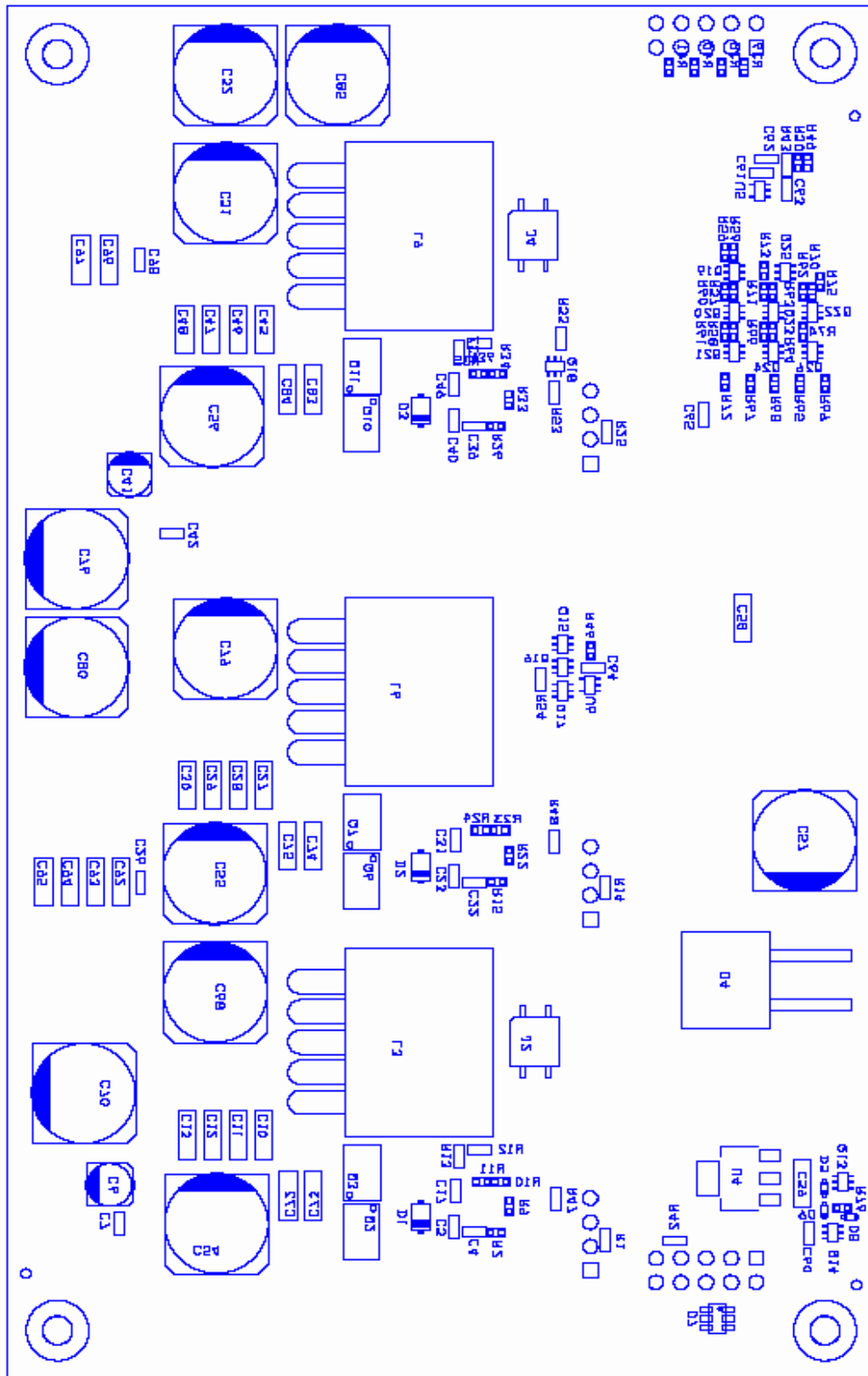

FIGURE 17. BOTTOM ASSEMBLY DRAWING

Bill of Materials

PART NUMBER	QTY	UNIT	REFERENCE DESIGNATOR	DESCRIPTION	MFR NAME	MFR PART
H1045-00104-16V10-T	7	ea	C7, C42, C60, C61, C63, C64, C65	CAP, SMD, 0603, 0.1 μ F, 16V, 10%, X7R, ROHS	MURATA	GRM39X7R104K016AD
H1045-00105-25V10-T	7	ea	C8, C9, C16, C24, C25, C43, C62	CAP, SMD, 0603, 1 μ F, 25V, 10%, X5R, ROHS	MURATA	GRM188R61E105KA12D
H1045-00106-6R3V20-T	6	ea	C17, C18, C31, C32, C49, C50	CAP, SMD, 0603, 10 μ F, 6.3V, 20%, X5R, ROHS	TDK	C1608X5R0J106M
H1045-00225-16V10-T	2	ea	C26, C98	CAP, SMD, 0603, 2.2 μ F, 16V, 10%, X5R, ROHS	MURATA	GRM188R61C225KE15D
H1045-00475-6R3V10-T	3	ea	C4, C22, C39	CAP, SMD, 0603, 4.7 μ F, 6.3V, 10%, X5R, ROHS	VENKEL	C0603X5R6R3-475KNE
H1045-DNP	0	ea	C44, C66, C99	CAP, SMD, 0603, DNP PLACE HOLDER, ROHS		
H1046-00225-25V10-T	3	ea	C5, C23, C40	CAP, SMD, 0805, 2.2 μ F, 25V, 10%, X5R, ROHS	PANASONIC	ECJ-2FB1E225K
H1065-00106-25V10-T	18	ea	a) C1, C2, C3, C19, C20, C21, C36, C37, C38, C58,	CAP, SMD, 1206, 10 μ F, 25V, 10%, X5R, ROHS	VENKEL	C1206X5R250-106KNE
H1065-00106-25V10-T	0	ea	b) C59, C72-C75, C83, C84, C105	CAP, SMD, 1206, 10 μ F, 25V, 10%, X5R, ROHS	VENKEL	C1206X5R250-106KNE
H1065-00476-6R3V20-T	30	ea	a) C10 to C15, C27 to C30, C33 to C35, C45 to C48,	CAP, SMD, 1206, 47 μ F, 6.3V, 20%, X5R, ROHS	MURATA	GRM31CR60J476ME19L
H1065-00476-6R3V20-T	0	ea	b) C53, C77, C78, C88 to C97	CAP, SMD, 1206, 47 μ F, 6.3V, 20%, X5R, ROHS	MURATA	GRM31CR60J476ME19L
APXA160ARA331MJC0G	7	ea	C54, C55, C56, C57, C101, C102, C103	CAP, SMD, 10x12, 330 μ F, 16V, 20%, 14m Ω , ALUM. ELEC., ROHS	NIPPON CHEMI-CON	APXA160ARA331MJC0G
APXA6R3ARA821MJC0G	9	ea	C51, C52, C68, C69, C70, C76, C79, C80, C85	CAP, SMD, 10x12, 820 μ F, 6.3V, 20%, 10m Ω , ALUM. ELEC., ROHS	NIPPON CHEMI-CON	APXA6R3ARA821MJC0G
EMVA250ADA100MD55G	2	ea	C6, C41	CAP, SMD, 4x5.2, 10 μ F, 25V, 20%, ALUM. ELEC., ROHS	NIPPON CHEMI-CON	EMVA250ADA100MD55G
EMZA6R3ADA102MHA0G	3	ea	C67, C81, C86	CAP, SMD, 8x10, 1000 μ F, 6.3V, 20%, ALUM. ELEC., ROHS	NIPPON CHEMI-CON	EMZA6R3ADA102MHA0G
EMZA6R3ADA102MHA0G	0	ea	DNP (C71, C82, C87)	CAP, SMD, 8x10, 1000 μ F, 6.3V, 20%, ALUM. ELEC., ROHS	NIPPON CHEMI-CON	EMZA6R3ADA102MHA0G
IHLP5050FDERR56M01	3	ea	L3, L6, L9	COIL-PWR INDUCTOR, SMD, 13mm, 0.56 μ H, 20%, 37A, ROHS	VISHAY	IHLP5050FDERR56M01
108-0740-001	6	ea	P1, P2, P3 (2 EACH)	CONN-JACK, BANANA-SS-SDRLESS, VERTICAL, ROHS	JOHNSON COMPONENTS	108-0740-001
142-0701-201	0	ea	DNP (J1, J3)	CONN-RF, SMA JACK, 50 Ω , BMT, ST	JOHNSON COMPONENTS	142-0701-201

Bill of Materials (Continued)

PART NUMBER	QTY	UNIT	REFERENCE DESIGNATOR	DESCRIPTION	MFR NAME	MFR PART
3-644456-4	3	ea	JP1, JP2, JP3	CONN-HEADER, 1x4, VERTICAL, TIN, WHT NYLON, ROHS	AMP/TYCO	3-644456-4
881545-2	4	ea	a) JP1-Pins 3 and 4, JP2-Pins 3 and 4,	CONN-JUMPER, SHUNT LP W/HANDLE, 2P, 2.54mm, BLK, ROHS	TYCO ELECTRONICS	881545-2
881545-2	0	ea	b) JP3-Pins 3 and 4, J13-Pins 1 and 2	CONN-JUMPER, SHUNT LP W/HANDLE, 2P, 2.54mm, BLK, ROHS	TYCO ELECTRONICS	881545-2
PJ-002A	1	ea	J6	CONN-POWER JACK, TH, 2.1mm, 16V@2.5A, BLK, R/A, ROHS	CUI, INC	PJ-002A
SSQ-105-02-T-D-RA	1	ea	J11	CONN-SOCKET STRIP, TH, 2x5, 2.54mm, TIN, R/A, ROHS	SAMTEC	SSQ-105-02-T-D-RA
TSW-105-07-T-D	1	ea	J13	CONN-HEADER, 2x5, BRKAWY, 2.54mm, TIN, ROHS	SAMTEC	TSW-105-07-T-D
TSW-105-08-T-D-RA	1	ea	J10	CONN-HEADER, 2X5, BRKAWY, 2.54mm, TIN, R/A, ROHS	SAMTEC	TSW-105-08-T-D-RA
BAT54XV2T1G-T	3	ea	D5, D6, D8	DIODE-SCHOTTKY, SMD, 2P, SOD523, 30V, 200mA, ROHS	ON SEMICONDUCTOR	BAT54XV2T1G
MBR0540T1G-T	3	ea	D1, D2, D3	DIODE-RECTIFIER, SMD, SOD-123, 2P, 40V, 0.5A, ROHS	ON SEMICONDUCTOR	MBR0540T1G
STPS20L45CG	1	ea	D4	DIODE-RECTIFIER, SCHOTTKY, SMD, D2PAK, 45V, 10A, ROHS	STMICRO ELECTRONICS	STPS20L45CG
CMD17-21VGC/TR8-T	3	ea	D9, D10, D11	LED, SMD, 0805, GREEN, CLEAR, 10mcd, 2.1V, 20mA, 570nm, ROHS	CHICAGO MINIATURE	CMD17-21VGC/TR8
BLM18BB750SN1-T	6	ea	L10, L11, L12, L13, L14, L15	FERRITE CHIP, SMD, 0603, 75Ω, 25%, 300mA, 0.7Ω, ROHS	MURATA	BLM18BB750SN1
BLM21AG102SN1D-T	0	ea	DNP (L2, L5, L8)	FERRITE CHIP, SMD, 0805, 1000Ω, 200mA, 100MHz, ROHS	MURATA	BLM21AG102SN1D
BLM21AG102SN1D-T	3	ea	L1, L4, L7	FERRITE CHIP, SMD, 0805, 1000Ω, 200mA, 100MHz, ROHS	MURATA	BLM21AG102SN1D
ESDA6V1-4BC6	1	ea	D7	DIODE-TVS, ESD, QUAD BI-DIRECTIONAL, 6P, SOT23-6L, 80W, ROHS	STMICRO ELECTRONICS	ESDA6V1-4BC6
MIC2920A-3.3WS	1	ea	U4	IC-LDO REGULATOR, 4P, SOT-223, 3.3V, 400mA, ROHS	MICREL	MIC2920A-3.3WS
SN74AUP1G02DCKR	1	ea	U6	IC-SINGLE 2-INPUT POSITIVE-NOR GATE, SMD, 5P, SC70-5, ROHS	TEXAS INSTRUMENTS	SN74AUP1G02DCKR

Bill of Materials (Continued)

PART NUMBER	QTY	UNIT	REFERENCE DESIGNATOR	DESCRIPTION	MFR NAME	MFR PART
SN74AUP1G17DCKR	1	ea	U5	IC-BUFFER, SCHMITT TRIGGER, 5P, SC-70-5, 3.6V, 4mA, ROHS	TEXAS INSTRUMENTS	SN74AUP1G17DCKR
ZL6100ALNFT	3	ea	U1, U2, U3	IC-DIGITAL DC-DC CONTROLLER, 36P, QFN, 6x6, ROHS	INTERSIL	ZL6100ALNFT
BSC016N03LSG	6	ea	Q3, Q4, Q7, Q8, Q11, Q12	TRANSIST-MOS, N-CHANNEL, 8P, PG-TDSON-8, 30V, 100A, ROHS	INFINEON TECHNOLOGY	BSC016N03LSG
BSC030N03LS G	3	ea	Q2, Q6, Q10	TRANSISTOR-MOS, N-CHANNEL, 8P, PG-TDSON-8, 30V, 100A, ROHS	INFINEON TECHNOLOGY	BSC030N03LS G
FDG6301N-T	13	ea	Q13, Q15 to Q26	TRANSIST-MOS, DUAL N-CHANNEL, SMD, SC70-6, 25V, 220mA, ROHS	FAIRCHILD	FDG6301N
FDG6304P	1	ea	Q14	TRANSIST-MOS, DUAL P-CHANNEL, 6P, SC70-6, -25V, -0.41A, ROHS	FAIRCHILD	FDG6304P
MMBT3904LT1G-T	3	ea	Q1, Q5, Q9	TRANSISTOR, NPN, SOT-23, 3P, 40V, 0.2A.0.35W, ROHS	ON SEMICONDUCTOR	MMBT3904LT1G-T
H2510-00R00-1/16W-T	15	ea	R5, R17, R29, R52, R77, R78, R79, R83 to R90	RES, SMD, 0402, 0 Ω , 1/16W, 5%, TF, ROHS	VENKEL	CR0402-16W-00T
H2510-01002-1/16W1-T	15	ea	a) R3, R16, R27, R39, R40, R41, R46, R49, R50,	RES, SMD, 0402, 10k, 1/16W, 1%, TF, ROHS	PANASONIC	ERJ-2RKF1002X
H2510-01002-1/16W1-T	0	ea	b) R65, R67, R68, R69, R72, R76	RES, SMD, 0402, 10k, 1/16W, 1%, TF, ROHS	PANASONIC	ERJ-2RKF1002X
H2510-01003-1/16W1-T	3	ea	R1, R14, R25	RES, SMD, 0402, 100k, 1/16W, 1%, TF, ROHS	PANASONIC	ERJ2RKF1003
H2510-01102-1/16W1-T	3	ea	R9, R22, R33	RES, SMD, 0402, 11k, 1/16W, 1%, TF, ROHS	PANASONIC	ERJ-2RKF1102V
H2510-01622-1/16W1-T	3	ea	R10, R23, R34	RES, SMD, 0402, 16.2k, 1/16W, 1%, TF, ROHS	PANASONIC	ERJ-2RKF1622
H2510-01962-1/16W1-T	1	ea	R56	RES, SMD, 0402, 19.6k, 1/16W, 1%, TF, ROHS	PANASONIC	ERJ-2RKF1962
H2510-02152-1/16W1-T	1	ea	R57	RES, SMD, 0402, 21.5k, 1/16W, 1%, TF, ROHS	PANASONIC	ERJ-2RKF2152X
H2510-02372-1/16W1-T	1	ea	R58	RES, SMD, 0402, 23.7k, 1/16W, 1%, TF, ROHS	PANASONIC	ERJ-2RKF2372V
H2510-02612-1/16W1-T	1	ea	R59	RES, SMD, 0402, 26.1k, 1/16W, 1%, TF, ROHS	VENKEL	CR0402-16W-2612FT
H2510-02701-1/16W1-T	1	ea	R38	RES, SMD, 0402, 2.7k, 1/16W, 1%, TF, ROHS	VENKEL	CR0402-16W-2701FT
H2510-02872-1/16W1-T	1	ea	R60	RES, SMD, 0402, 28.7k, 1/16W, 1%, TF, ROHS	PANASONIC	ERJ-2RKF2872X

Bill of Materials (Continued)

PART NUMBER	QTY	UNIT	REFERENCE DESIGNATOR	DESCRIPTION	MFR NAME	MFR PART
H2510-03162-1/16W1-T	1	ea	R61	RES, SMD, 0402, 31.6k, 1/16W, 1%, TF, ROHS	VENKEL	CR0402-16W-3162FT
H2510-03482-1/16W1-T	4	ea	R11, R24, R35, R62	RES, SMD, 0402, 34.8k, 1/16W, 1%, TF, ROHS	PANASONIC	ERJ-2RKF3482
H2510-03832-1/16W1-T	1	ea	R63	RES, SMD, 0402, 38.3k, 1/16W, 1%, TF, ROHS	PANASONIC	ERJ-2RKF3832
H2510-04222-1/16W1-T	1	ea	R64	RES, SMD, 0402, 42.2k, 1/16W, 1%, TF, ROHS	PANASONIC	ERJ-2RKF4222X
H2510-04642-1/16W1-T	1	ea	R70	RES, SMD, 0402, 46.4k, 1/16W, 1%, TF, ROHS	PANASONIC	ERJ2RKF4642
H2510-05112-1/16W1-T	1	ea	R71	RES, SMD, 0402, 51.1k, 1/16W, 1%, TF, ROHS	PANASONIC	ERJ-2RKF5112X
H2510-05622-1/16W1-T	1	ea	R66	RES, SMD, 0402, 56.2k, 1/16W, 1%, TF, ROHS	PANASONIC	ERJ-2RKF5622
H2510-06192-1/16W1-T	1	ea	R75	RES, SMD, 0402, 61.9k, 1/16W, 1%, TF, ROHS	VENKEL	CR0402-16W-6192FT
H2510-06812-1/16W1-T	1	ea	R73	RES, SMD, 0402, 68.1k, 1/16W, 1%, TF, ROHS	VENKEL	CR0402-16W-6812FT
H2510-07502-1/16W1-T	1	ea	R74	RES, SMD, 0402, 75k, 1/16W, 1%, TF, ROHS	VENKEL	CR0402-16W-7502FT
H2510-DNP	0	ea	R2, R15, R26	RES, SMD, 0402, DNP, DNP, DNP, TF, ROHS		
H2511-00010-1/10W1-T	2	ea	R4, R18	RES, SMD, 0603, 1 Ω , 1/10W, 1%, TF, ROHS	PANASONIC	ERJ-3RQF1R0V
H2511-00R00-1/10W-T	7	ea	R6, R19, R28, R30, R51, R82, R93	RES, SMD, 0603, 0 Ω , 1/10W, TF, ROHS	VENKEL	CR0603-10W-000T
H2511-01871-1/10W1-T	3	ea	R8, R21, R32	RES, SMD, 0603, 1.87k, 1/10W, 1%, TF, ROHS	VENKEL	CR0603-10W-1871FT
H2511-03650-1/10W1-T	3	ea	R7, R20, R31	RES, SMD, 0603, 365 Ω , 1/10W, 1%, TF, ROHS	VENKEL	CR0603-10W-3650FT
H2511-03920-1/10W1-T	5	ea	R47, R48, R53, R54,	RES, SMD, 0603, 392 Ω , 1/10W, 1%, TF, ROHS	PANASONIC	ERJ-3EKF3920V
H2511-049R9-1/10W1-T	2	ea	R42, R43	RES, SMD, 0603, 49.9 Ω , 1/10W, 1%, TF, ROHS	VENKEL	CR0603-10W-49R9FT
H2511-DNP	0	ea	R12, R13, R36, R37, R44, R45, R80, R81, R91, R92	RES, SMD, 0603, DNP-PLACE HOLDER, ROHS		
G13AP-RO	1	ea	SW1	SWITCH-TOGGLE, THRU-HOLE, 5P, SPDT, 3POS, ON-OFF-ON, ROHS	NKK	G13AP-RO
4-40X1/4-SCREW-SS	4	ea	Four corners	SCREW, 4-40x1/4in, PHILLIPS, PAN, STAINLESS STEEL, ROHS	KEYSTONE	9900
DNP	0	ea	C100, C104, C110	DO NOT POPULATE OR PURCHASE		
DNP	0	ea	D12, D13, D14	DO NOT POPULATE OR PURCHASE		

Bill of Materials (Continued)

PART NUMBER	QTY	UNIT	REFERENCE DESIGNATOR	DESCRIPTION	MFR NAME	MFR PART
DNP	0	ea	J2, J4	DO NOT POPULATE OR PURCHASE		
DNP	0	ea	JP4, JP5, JP6, JP7, JP8	DO NOT POPULATE OR PURCHASE		
DNP	0	ea	a) TP1-TP10, TP12-TP40, TP42, TP43, TP46,	DO NOT POPULATE OR PURCHASE		
DNP	0	ea	b) TP48 to TP56, TP58 to TP65, TP67, TP68,	DO NOT POPULATE OR PURCHASE		
DNP	0	ea	c) TP70 to TP75	DO NOT POPULATE OR PURCHASE		
VC-234-8	6	ea	P1, P2, P3 (COVER BOTTOMS OF POSTS)	CAPLUG-ROUND VINYL CLOSURE, FLEXIBLE, 0.5x0.234, ROHS	CAPLUGS	VC-234-8
H1045-00104-16V10-T	7	ea	C7, C42, C60, C61, C63, C64, C65	CAP, SMD, 0603, 0.1 μ F, 16V, 10%, X7R, ROHS	MURATA	GRM39X7R104K016AD

Default Configuration Text

The following text is loaded into the ZL6100 devices on the EV2 as default settings. Each PMBus command is loaded via the PowerNavigator software. The # symbol is used for a comment line.

```
# Configuration file for ZL6100EVAL2Z-Ch1A
#Erase default and user stores
RESTORE_FACTORY
STORE_USER_ALL
STORE_DEFAULT_ALL
RESTORE_DEFAULT_ALL
```

```
MFR_ID           Zilker_Labs
MFR_MODEL        ZL6100EVAL2ZR2
MFR_REVISION     Cfg Rev 1.1
MFR_LOCATION     Austin_TX
MFR_DATE         08_27_09
MFR_SERIAL       ch1A
```

```
VOUT_COMMAND     1.80
VOUT_DROOP       0.5
VOUT_UV_Fault_LIMIT 1.53
VOUT_UV_FAULT_RESPONSE 0x80
VOUT_OV_Fault_LIMIT 2.07
VOUT_OV_FAULT_RESPONSE 0x80
OVUV_CONFIG      0x80
```

```
IOUT_SCALE       1.13
IOUT_CAL_OFFSET  1.00
```

```
IOUT_OC_FAULT_LIMIT 45.0
IOUT_AVG_OC_FAULT_LIMIT 40.0
IOUT_UC_FAULT_LIMIT -40.0
IOUT_AVG_UC_FAULT_LIMIT -40.0
MFR_IOUT_OC_FAULT_RESPONSE 0xBF
MFR_IOUT_UC_FAULT_RESPONSE 0xBF
```

```
VIN_OV_FAULT_LIMIT 14.0
VIN_OV_WARN_LIMIT 13.5
VIN_OV_FAULT_RESPONSE 0x80
```

```
VIN_UV_WARN_LIMIT 4.641
VIN_UV_FAULT_LIMIT 4.50
VIN_UV_FAULT_RESPONSE 0x80
```

```
OT_FAULT_RESPONSE 0xBF
UT_FAULT_RESPONSE 0xBF
```

```
POWER_GOOD_ON 1.35
POWER_GOOD_DELAY 10.0
```

```
TON_DELAY 15
TON_RISE 5
TOFF_DELAY 15
TOFF_FALL 5
```

ZL6100EVAL2Z

```
DEADTIME          0x3838
DEADTIME_CONFIG  0x0606
MAX_DUTY          96
INDUCTOR          0.56

FREQUENCY_SWITCH  300 # kHz

#CompZL Taps for G=36,      Q=0.25,      f=3.5kHz,      fsw=300kHz, Vi=12, Vo=1.8
PID_TAPS    A=13553.75, B=-23599.50, C=10109.25 # dIo=30-45A @ 2.5A/us, dVo=+/-3%

# Advanced
USER_CONFIG      0x6050 # SYNC Input
MFR_CONFIG       0x82D4
INTERLEAVE       0x0000
TEMPCO_CONFIG    0xA4
TRACK_CONFIG     0x00

# Advanced 2
MISC_CONFIG      0x4080
ISHARE_CONFIG    0x0121 # Ishare Group 1, members 2, position 1, CS En
DDC_CONFIG       0x0101 # DDC Rail ID 1, Broadcast Group 1
DDC_GROUP        0x00000000

STORE_DEFAULT_ALL
RESTORE_DEFAULT_ALL

-----
# Configuration file for ZL6100EVAL2Z-Ch1B

#Erase default and user stores
RESTORE_FACTORY
STORE_DEFAULT_ALL
STORE_USER_ALL
RESTORE_DEFAULT_ALL

MFR_ID           Zilker_Labs
MFR_MODEL        ZL6100EVAL2ZR2
MFR_REVISION     Cfg Rev 1.1
MFR_LOCATION     Austin_TX
MFR_DATE         08_27_09
MFR_SERIAL       ch1B

VOUT_COMMAND     1.80
VOUT_DROOP       0.5
VOUT_UV_Fault_LIMIT 1.53
VOUT_UV_FAULT_RESPONSE 0x80
VOUT_OV_Fault_LIMIT 2.07
VOUT_OV_FAULT_RESPONSE 0x80
OVUV_CONFIG      0x80

IOUT_SCALE       1.13
IOUT_CAL_OFFSET 1.00

IOUT_OC_FAULT_LIMIT 45.0
IOUT_AVG_OC_FAULT_LIMIT 40.0
IOUT_UC_FAULT_LIMIT -40.0
```

ZL6100EVAL2Z

IOUT_AVG_UC_FAULT_LIMIT -40.0
MFR_IOUT_OC_FAULT_RESPONSE 0xBF
MFR_IOUT_UC_FAULT_RESPONSE 0xBF

VIN_OV_FAULT_LIMIT 14.0
VIN_OV_WARN_LIMIT 13.5
VIN_OV_FAULT_RESPONSE 0x80

VIN_UV_WARN_LIMIT 4.641
VIN_UV_FAULT_LIMIT 4.50
VIN_UV_FAULT_RESPONSE 0x80

OT_FAULT_RESPONSE 0xBF
UT_FAULT_RESPONSE 0xBF

POWER_GOOD_ON 1.35
POWER_GOOD_DELAY 10.0

TON_DELAY 5
TON_RISE 5
TOFF_DELAY 5
TOFF_FALL 5
DEADTIME 0x3838
DEADTIME_CONFIG 0x0606
MAX_DUTY 96
INDUCTOR 0.56

FREQUENCY_SWITCH 300 # kHz

#CompZL Taps for G=36, Q=0.25, f=3.5kHz, fsw=300kHz, Vi=12, Vo=1.8
PID_TAPS A=13553.75, B=-23599.50, C=10109.25 # dIo=30-45A @ 2.5A/us, dVo=+/-3%

Advanced
USER_CONFIG 0x6050 # SYNC INPUT
MFR_CONFIG 0x82D4
INTERLEAVE 0x0000
TEMPCO_CONFIG 0xA4
TRACK_CONFIG 0x00

Advanced 2
MISC_CONFIG 0x4080
ISHARE_CONFIG 0x0125 # Ishare Group 1, members 2, position 2, CS En
DDC_CONFIG 0x0101 # DDC Rail ID 1, Broadcast Group 1
DDC_GROUP 0x00000000
STORE_DEFAULT_ALL
RESTORE_DEFAULT_ALL

ZL6100EVAL2Z

Configuration file for ZL6100EVAL2Z-Ch2

#Erase default and user stores

RESTORE_FACTORY
STORE_DEFAULT_ALL
STORE_USER_ALL
RESTORE_DEFAULT_ALL

MFR_ID Zilker_Labs
MFR_MODEL ZL6100EVAL2ZR2
MFR_REVISION Cfg Rev 1.1
MFR_LOCATION Austin_TX
MFR_DATE 08_27_09
MFR_SERIAL ch2

VOUT_COMMAND 1.50
VOUT_DROOP 0.0
VOUT_UV_Fault_LIMIT 1.275
VOUT_UV_FAULT_RESPONSE 0x80
VOUT_OV_Fault_LIMIT 1.80
VOUT_OV_FAULT_RESPONSE 0x80
OVUV_CONFIG 0x80

IOUT_SCALE 1.16
IOUT_CAL_OFFSET -0.25

IOUT_OC_FAULT_LIMIT 45.0
IOUT_AVG_OC_FAULT_LIMIT 38.0
IOUT_UC_FAULT_LIMIT -15.0
IOUT_AVG_UC_FAULT_LIMIT -12.0
MFR_IOUT_OC_FAULT_RESPONSE 0xBF
MFR_IOUT_UC_FAULT_RESPONSE 0xBF

VIN_OV_FAULT_LIMIT 14.0
VIN_OV_WARN_LIMIT 13.5
VIN_OV_FAULT_RESPONSE 0x80

VIN_UV_WARN_LIMIT 4.641
VIN_UV_FAULT_LIMIT 4.50
VIN_UV_FAULT_RESPONSE 0x80

OT_FAULT_RESPONSE 0xBF
UT_FAULT_RESPONSE 0xBF

POWER_GOOD_ON 1.35
POWER_GOOD_DELAY 10

TON_DELAY 20
TON_RISE 5
TOFF_DELAY 20
TOFF_FALL 5
DEADTIME 0x3838
DEADTIME_CONFIG 0x0606
MAX_DUTY 96
INDUCTOR 0.56

FREQUENCY_SWITCH 300 # kHz

CompZL Taps for G=37, Q=0.25, f=3.5kHz, fsw=300kHz, Vi=12, Vo=1.5
PID_TAPS A=15207.50, B=-26479.50, C=11342.75 # dIo=15-22.5A @ 2.5A/us, dVo=+/-3%

```
# Advanced
USER_CONFIG          0x0030 # SYNC Output
MFR_CONFIG           0x82D5
INTERLEAVE           0x0140
TEMPCO_CONFIG        0xA8
TRACK_CONFIG         0x00

# Advanced 2
MISC_CONFIG          0x0080
ISHARE_CONFIG        0x0200 # Ishare Group 2, members 1, position 1, CS disabled
DDC_CONFIG           0x0202 # DDC Rail ID 2, Broadcast Group 2
DDC_GROUP            0x00000000
STORE_DEFAULT_ALL
RESTORE_DEFAULT_ALL
```

Measured Data

The following data was acquired using a ZL6100EVAL2Z rev 3 evaluation board.

Efficiency

The measured input power includes the quiescent current for all three controllers on the evaluation board and is included in the efficiency measurement for the separate channels. Adaptive diode emulation and adaptive frequency modes are disabled for these efficiency measurements.

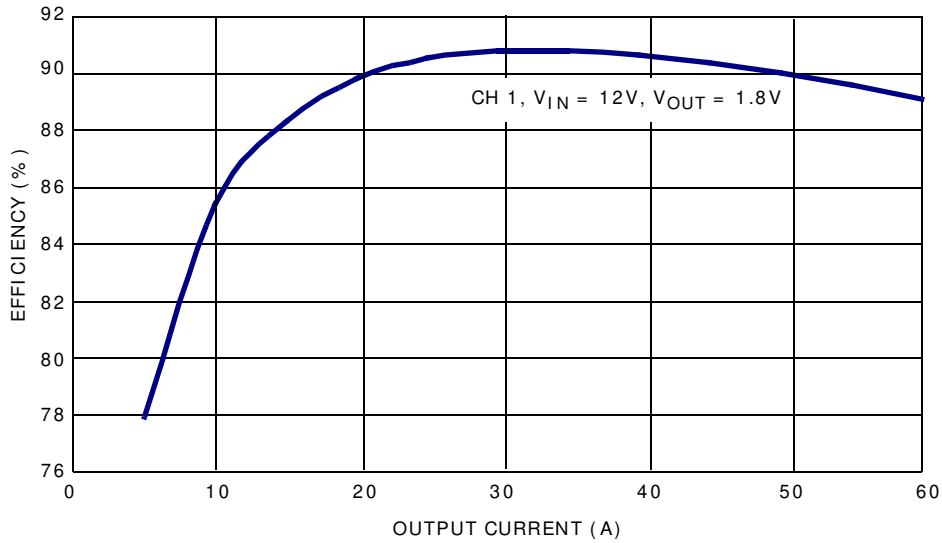

FIGURE 18. CHANNEL 1 EFFICIENCY

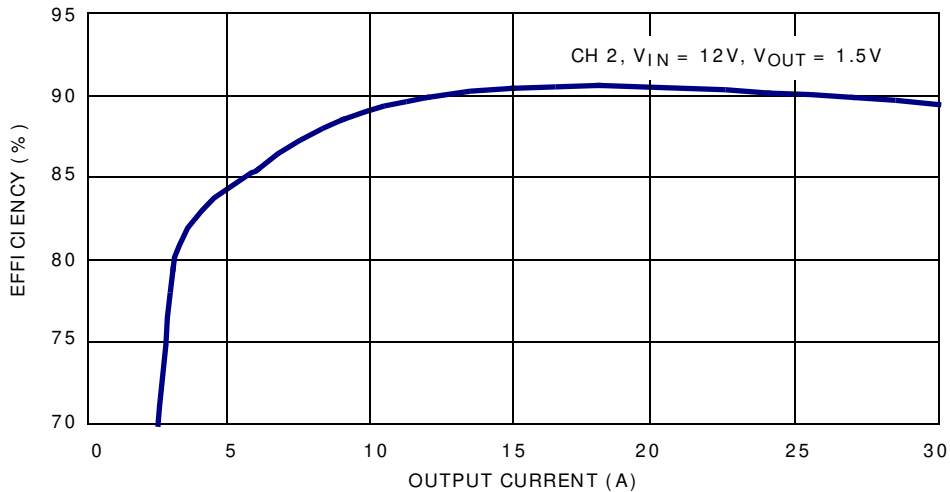

FIGURE 19. CHANNEL 2 EFFICIENCY

Ramp-up/ Ramp-down Characteristics

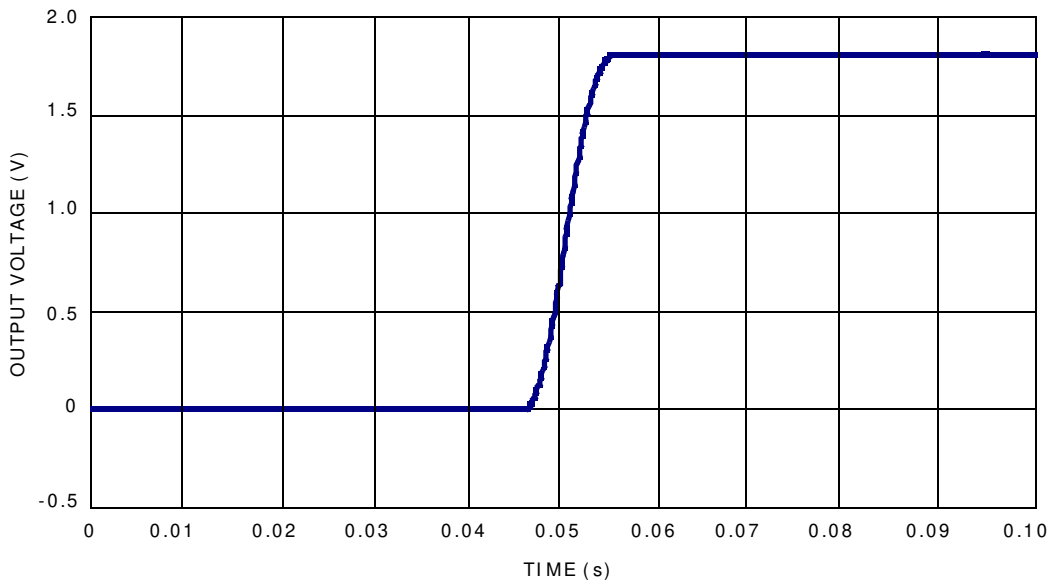

FIGURE 20. CHANNEL 1 RAMP UP

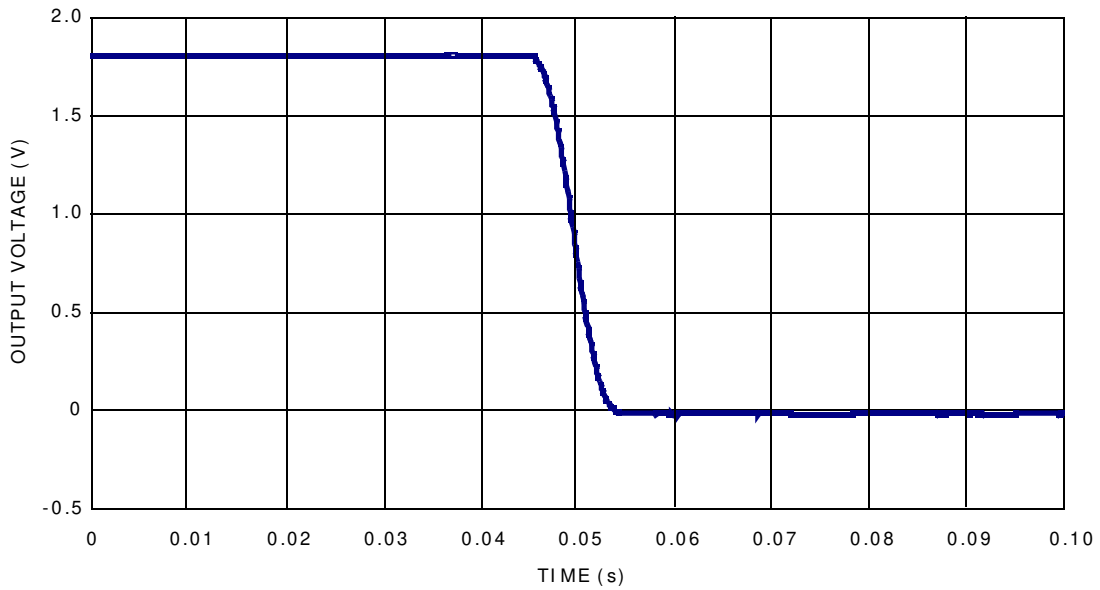

FIGURE 21. CHANNEL 1 RAMP DOWN

Ramp-up/ Ramp-down Characteristics (Continued)

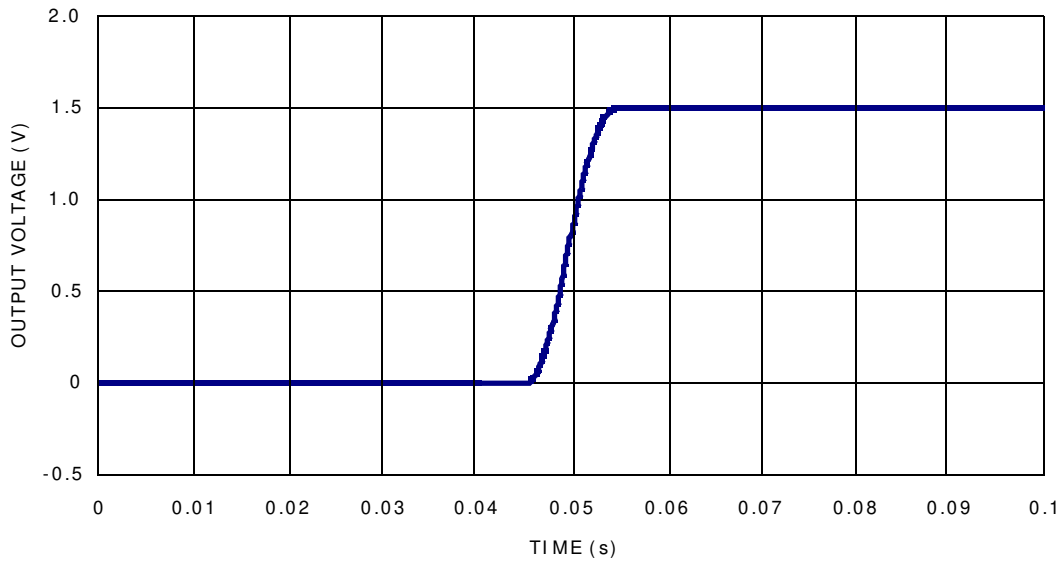

FIGURE 22. CHANNEL 2 RAMP UP

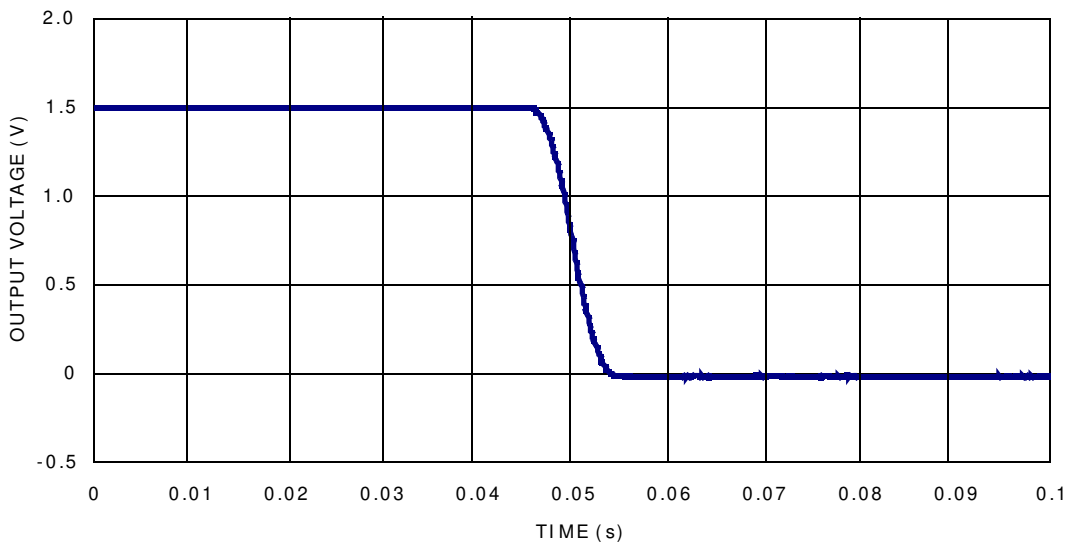

FIGURE 23. CHANNEL 2 RAMP DOWN

Dynamic Load Response

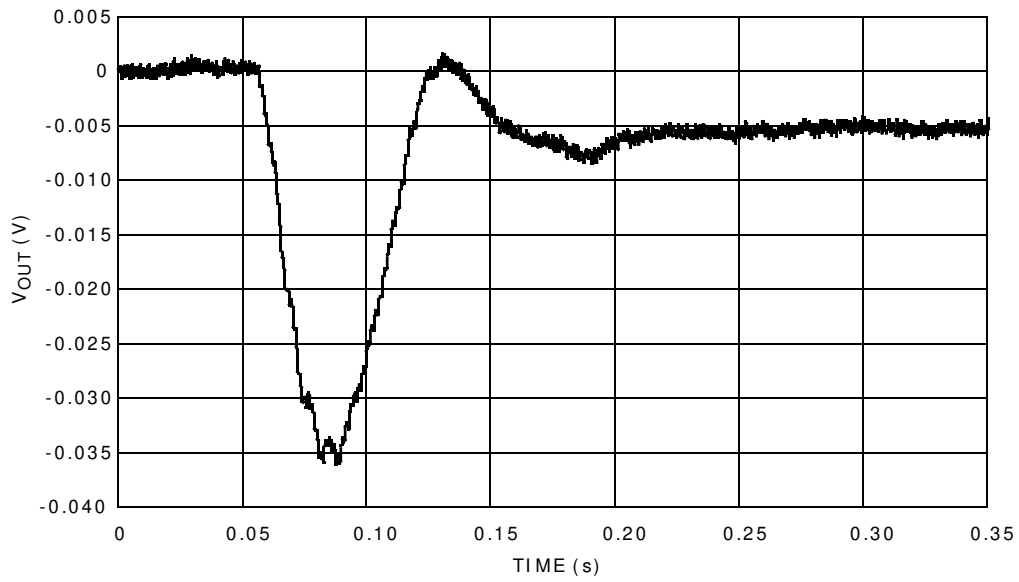

FIGURE 24. CHANNEL 1 DYNAMIC RESPONSE, 30A TO 42A LOAD STEP

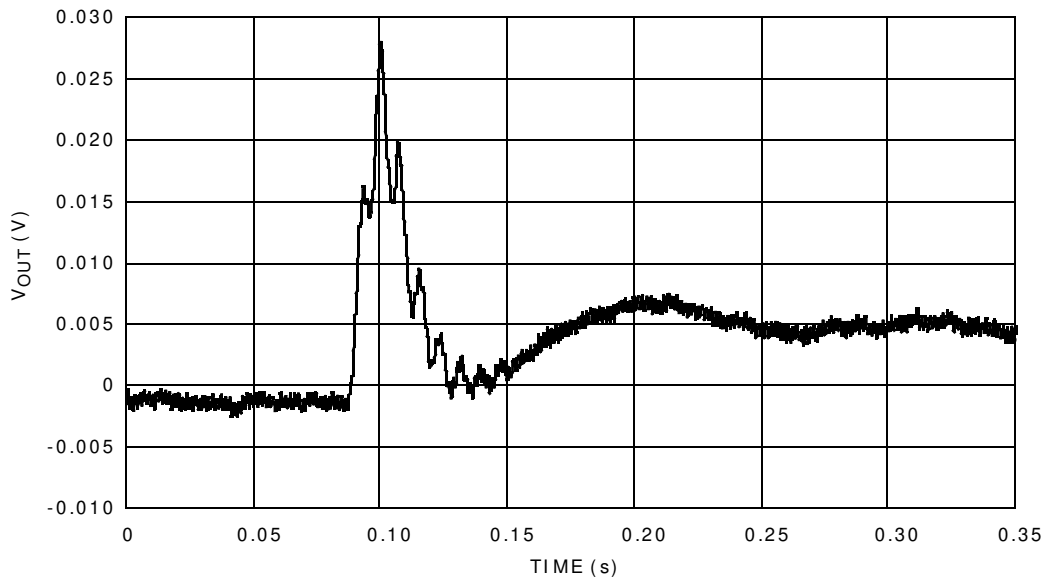

FIGURE 25. CHANNEL 1 DYNAMIC RESPONSE, 42A TO 30A LOAD STEP

Dynamic Load Response (Continued)

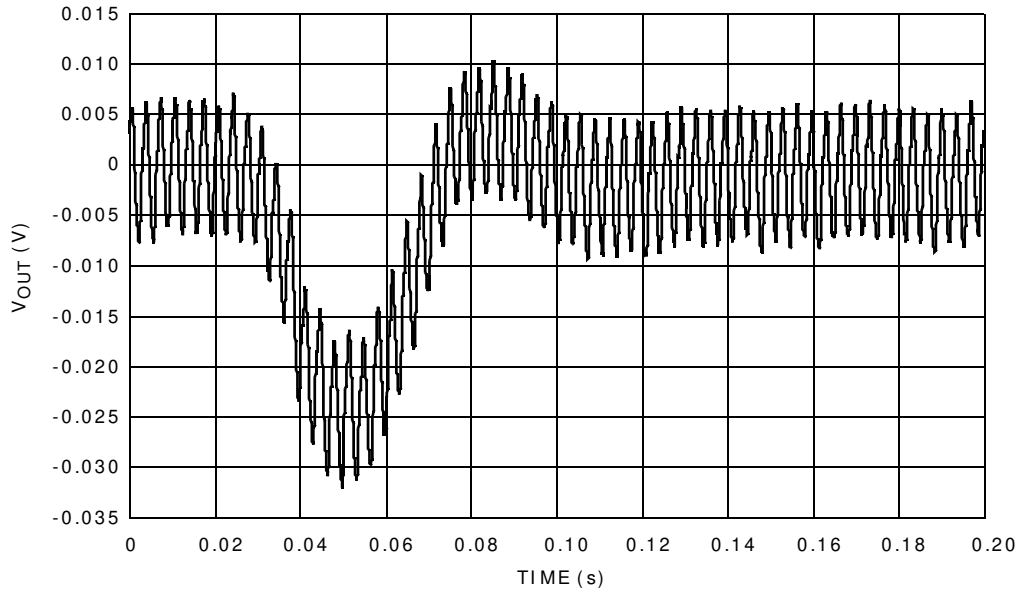

FIGURE 26. CHANNEL 2 DYNAMIC RESPONSE, 21A TO 15A LOAD STEP

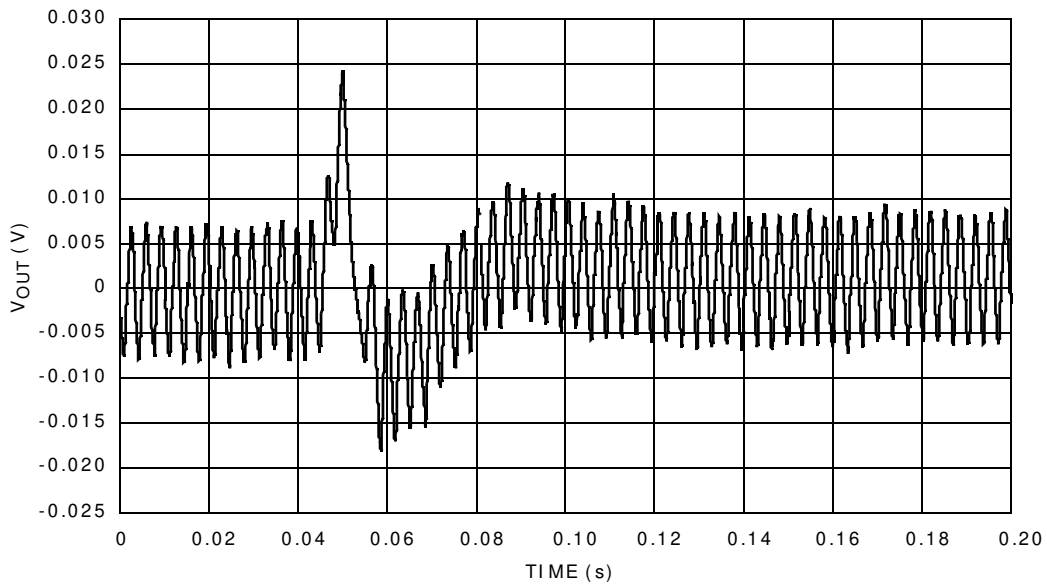

FIGURE 27. CHANNEL 2 DYNAMIC RESPONSE, 15A TO 21A LOAD STEP

ORDERABLE PART NUMBER	DESCRIPTION
ZL6100EVAL2Z	ZL6100 Two Channel Evaluation Kit (EVB, USB Adapter, Cable, Software)

References

12. *ZL6100 Data Sheet*, Intersil Corporation, 2009.
13. AN2033 – *PMBus™ Command Set*, Intersil Corporation, 2009.

Notice

1. Descriptions of circuits, software and other related information in this document are provided only to illustrate the operation of semiconductor products and application examples. You are fully responsible for the incorporation or any other use of the circuits, software, and information in the design of your product or system. Renesas Electronics disclaims any and all liability for any losses and damages incurred by you or third parties arising from the use of these circuits, software, or information.
 2. Renesas Electronics hereby expressly disclaims any warranties against and liability for infringement or any other claims involving patents, copyrights, or other intellectual property rights of third parties, by or arising from the use of Renesas Electronics products or technical information described in this document, including but not limited to, the product data, drawings, charts, programs, algorithms, and application examples.
 3. No license, express, implied or otherwise, is granted hereby under any patents, copyrights or other intellectual property rights of Renesas Electronics or others.
 4. You shall not alter, modify, copy, or reverse engineer any Renesas Electronics product, whether in whole or in part. Renesas Electronics disclaims any and all liability for any losses or damages incurred by you or third parties arising from such alteration, modification, copying or reverse engineering.
 5. Renesas Electronics products are classified according to the following two quality grades: "Standard" and "High Quality". The intended applications for each Renesas Electronics product depends on the product's quality grade, as indicated below.
"Standard": Computers; office equipment; communications equipment; test and measurement equipment; audio and visual equipment; home electronic appliances; machine tools; personal electronic equipment; industrial robots; etc.
"High Quality": Transportation equipment (automobiles, trains, ships, etc.); traffic control (traffic lights); large-scale communication equipment; key financial terminal systems; safety control equipment; etc.
Unless expressly designated as a high reliability product or a product for harsh environments in a Renesas Electronics data sheet or other Renesas Electronics document, Renesas Electronics products are not intended or authorized for use in products or systems that may pose a direct threat to human life or bodily injury (artificial life support devices or systems; surgical implantations; etc.), or may cause serious property damage (space system; undersea repeaters; nuclear power control systems; aircraft control systems; key plant systems; military equipment; etc.). Renesas Electronics disclaims any and all liability for any damages or losses incurred by you or any third parties arising from the use of any Renesas Electronics product that is inconsistent with any Renesas Electronics data sheet, user's manual or other Renesas Electronics document.
 6. When using Renesas Electronics products, refer to the latest product information (data sheets, user's manuals, application notes, "General Notes for Handling and Using Semiconductor Devices" in the reliability handbook, etc.), and ensure that usage conditions are within the ranges specified by Renesas Electronics with respect to maximum ratings, operating power supply voltage range, heat dissipation characteristics, installation, etc. Renesas Electronics disclaims any and all liability for any malfunctions, failure or accident arising out of the use of Renesas Electronics products outside of such specified ranges.
 7. Although Renesas Electronics endeavors to improve the quality and reliability of Renesas Electronics products, semiconductor products have specific characteristics, such as the occurrence of failure at a certain rate and malfunctions under certain use conditions. Unless designated as a high reliability product or a product for harsh environments in a Renesas Electronics data sheet or other Renesas Electronics document, Renesas Electronics products are not subject to radiation resistance design. You are responsible for implementing safety measures to guard against the possibility of bodily injury, injury or damage caused by fire, and/or danger to the public in the event of a failure or malfunction of Renesas Electronics products, such as safety design for hardware and software, including but not limited to redundancy, fire control and malfunction prevention, appropriate treatment for aging degradation or any other appropriate measures. Because the evaluation of microcomputer software alone is very difficult and impractical, you are responsible for evaluating the safety of the final products or systems manufactured by you.
 8. Please contact a Renesas Electronics sales office for details as to environmental matters such as the environmental compatibility of each Renesas Electronics product. You are responsible for carefully and sufficiently investigating applicable laws and regulations that regulate the inclusion or use of controlled substances, including without limitation, the EU RoHS Directive, and using Renesas Electronics products in compliance with all these applicable laws and regulations. Renesas Electronics disclaims any and all liability for damages or losses occurring as a result of your noncompliance with applicable laws and regulations.
 9. Renesas Electronics products and technologies shall not be used for or incorporated into any products or systems whose manufacture, use, or sale is prohibited under any applicable domestic or foreign laws or regulations. You shall comply with any applicable export control laws and regulations promulgated and administered by the governments of any countries asserting jurisdiction over the parties or transactions.
 10. It is the responsibility of the buyer or distributor of Renesas Electronics products, or any other party who distributes, disposes of, or otherwise sells or transfers the product to a third party, to notify such third party in advance of the contents and conditions set forth in this document.
 11. This document shall not be reprinted, reproduced or duplicated in any form, in whole or in part, without prior written consent of Renesas Electronics.
 12. Please contact a Renesas Electronics sales office if you have any questions regarding the information contained in this document or Renesas Electronics products.
- (Note 1) "Renesas Electronics" as used in this document means Renesas Electronics Corporation and also includes its directly or indirectly controlled subsidiaries.
(Note 2) "Renesas Electronics product(s)" means any product developed or manufactured by or for Renesas Electronics.

(Rev.4.0-1 November 2017)



SALES OFFICES

Renesas Electronics Corporation

<http://www.renesas.com>

Refer to "<http://www.renesas.com/>" for the latest and detailed information.

Renesas Electronics Corporation

TOYOSU FORESIA, 3-2-24 Toyosu, Koto-ku, Tokyo 135-0061, Japan

Renesas Electronics America Inc.

1001 Murphy Ranch Road, Milpitas, CA 95035, U.S.A.
Tel: +1-408-432-8888, Fax: +1-408-434-5351

Renesas Electronics Canada Limited

9251 Yonge Street, Suite 8309 Richmond Hill, Ontario Canada L4C 9T3
Tel: +1-905-237-2004

Renesas Electronics Europe Limited

Dukes Meadow, Millboard Road, Bourne End, Buckinghamshire, SL8 5FH, U.K
Tel: +44-1628-651-700

Renesas Electronics Europe GmbH

Arcadiastrasse 10, 40472 Düsseldorf, Germany
Tel: +49-211-6503-0, Fax: +49-211-6503-1327

Renesas Electronics (China) Co., Ltd.

Room 1709 Quantum Plaza, No.27 ZhichunLu, Haidian District, Beijing, 100191 P. R. China
Tel: +86-10-8235-1155, Fax: +86-10-8235-7679

Renesas Electronics (Shanghai) Co., Ltd.

Unit 301, Tower A, Central Towers, 555 Langao Road, Putuo District, Shanghai, 200333 P. R. China
Tel: +86-21-2226-0888, Fax: +86-21-2226-0999

Renesas Electronics Hong Kong Limited

Unit 1601-1611, 16/F., Tower 2, Grand Century Place, 193 Prince Edward Road West, Mongkok, Kowloon, Hong Kong
Tel: +852-2265-6688, Fax: +852 2886-9022

Renesas Electronics Taiwan Co., Ltd.

13F, No. 363, Fu Shing North Road, Taipei 10543, Taiwan
Tel: +886-2-8175-9600, Fax: +886 2-8175-9670

Renesas Electronics Singapore Pte. Ltd.

80 Bendemeer Road, Unit #06-02 Hyflux Innovation Centre, Singapore 339949
Tel: +65-6213-0200, Fax: +65-6213-0300

Renesas Electronics Malaysia Sdn.Bhd.

Unit 1207, Block B, Menara Amcorp, Amcorp Trade Centre, No. 18, Jln Persiaran Barat, 46050 Petaling Jaya, Selangor Darul Ehsan, Malaysia
Tel: +60-3-7955-9390, Fax: +60-3-7955-9510

Renesas Electronics India Pvt. Ltd.

No.777C, 100 Feet Road, HAL 2nd Stage, Indiranagar, Bangalore 560 038, India
Tel: +91-80-67208700, Fax: +91-80-67208777

Renesas Electronics Korea Co., Ltd.

17F, KAMCO Yangjae Tower, 262, Gangnam-daero, Gangnam-gu, Seoul, 06265 Korea
Tel: +82-2-558-3737, Fax: +82-2-558-5338