

DESIGNED AND DIMENSIONED IN MILLIMETERS[INCHES]
ALL DIMENSIONS REFERENCE EXCEPT AS SHOWN

DO NOT SCALE FROM THIS PRINT

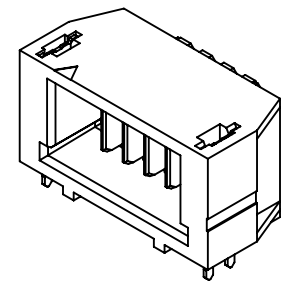
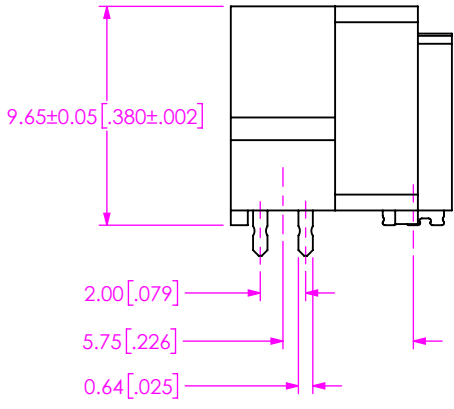
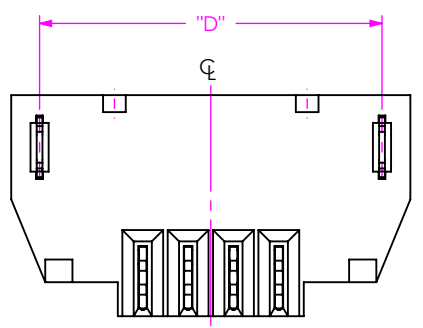
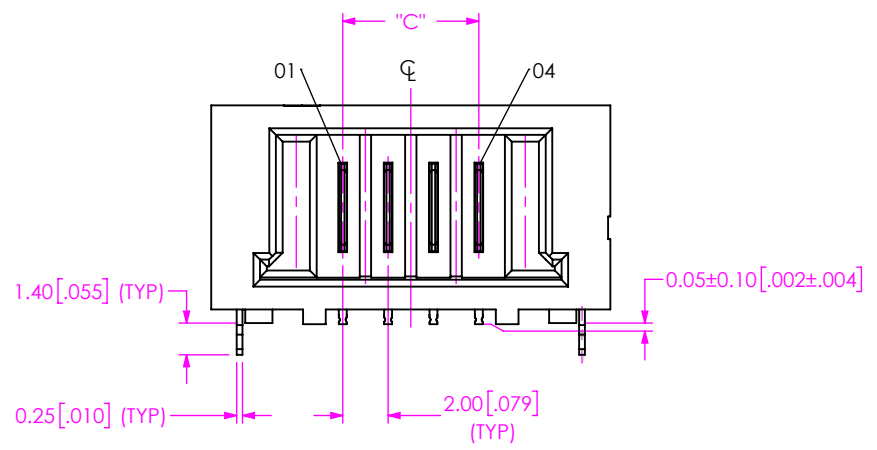
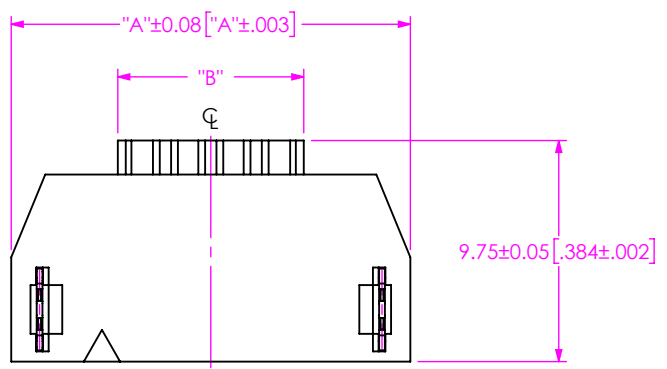

FIG 1
UMPT-04-01-XX-RA-WT SHOWN

UMPT-XX-XX-XX-RA-WX-X-XR

No OF POSITIONS
-02, -03, -04, -05,
-06, -07, -08, -09,
-10

LEAD STYLE
-01: SURFACE MOUNT

PLATING
-T: MATTE TIN
-L: 10µ" SELECTIVE GOLD IN CONTACT AREA, MATTE TIN ON TAIL, MATTE TIN ON THE WELD TAB.
-S: 30µ" SELECTIVE GOLD IN CONTACT AREA, MATTE TIN ON TAIL, MATTE TIN ON THE WELD TAB.
-SL: 30µ" SELECTIVE GOLD IN CONTACT AREA, TIN-LEAD ON TAIL, TIN-LEAD ON THE WELD TAB.

TAPE & REEL (SEE NOTE 3 & 4)
-TR: TAPE & REEL
-FR: FULL REEL QTY TAPE & REEL

LATCH OPTIONS
(LEAVE BLANK FOR NO LATCH)
-P: PLASTIC TOP LATCH
-M: METAL SIDE LATCHES

WELD TAB OPTIONS
-WT: WELD TAB THROUGH HOLE
*-WS: WELD TAB SURFACE MOUNT

ORIENTATION
-RA: RIGHT ANGLE

(* = NOT TOOLED)

TABLE 1				
No. OF POS	"A"	"B"	"C"	"D"
-02	13.60 [.535]	4.20 [.165]	2.00 [.079]	11.10 [.437]
-03	15.60 [.614]	6.20 [.244]	4.00 [.157]	13.10 [.516]
-04	17.60 [.693]	8.20 [.323]	6.00 [.236]	15.10 [.594]
-05	19.60 [.772]	10.20 [.402]	8.00 [.315]	17.10 [.673]
-06	21.60 [.850]	12.20 [.480]	10.00 [.394]	19.10 [.752]
-07	23.60 [.929]	14.20 [.559]	12.00 [.472]	21.10 [.831]
-08	25.60 [1.008]	16.20 [.638]	14.00 [.551]	23.10 [.909]
-09	27.60 [1.087]	18.20 [.717]	16.00 [.630]	25.10 [.988]
-10	29.60 [1.165]	20.20 [.795]	18.00 [.709]	27.10 [1.067]

NOTES:

- NOTE DELETED.
- NOTE DELETED.
- ATTACH LABEL -4x2 TO EACH REEL.
- ORDERS WILL BE PACKAGED ACCORDING TO THE SAMTEC PACKAGING EFFICIENCY STANDARDS (SPES) FOUND ON WWW.SAMTEC.COM.

PROPRIETARY NOTE
THIS DOCUMENT CONTAINS CONFIDENTIAL AND PROPRIETARY INFORMATION AND ALL DESIGN, MANUFACTURING, REPRODUCTION, USE, PATENT RIGHTS AND SALES RIGHTS ARE EXPRESSLY RESERVED BY SAMTEC, INC. THIS DOCUMENT SHALL NOT BE DISCLOSED, IN WHOLE OR PART, TO ANY UNAUTHORIZED PERSON OR ENTITY NOR REPRODUCED, TRANSFERRED OR INCORPORATED IN ANY OTHER PROJECT IN ANY MANNER WITHOUT THE EXPRESS WRITTEN CONSENT OF SAMTEC, INC.

DO NOT SCALE DRAWING
SHEET SCALE: 1:2

MATERIAL:
INSULATOR: LCP
TERMINAL: COPPER ALLOY
WELD TAB: COPPER ALLOY

samtec
520 PARK EAST BLVD, NEW ALBANY, IN 47150
PHONE: 812-944-6733 FAX: 812-948-5047
e-Mail info@SAMTEC.com code 5332

DESCRIPTION:
ULTRA MICRO POWER RA TERMINAL

DWG. NO.
UMPT-XX-XX-XX-RA-WX-X-XR

BY: ETHAN C 06/12/2019 SHEET 1 OF 2

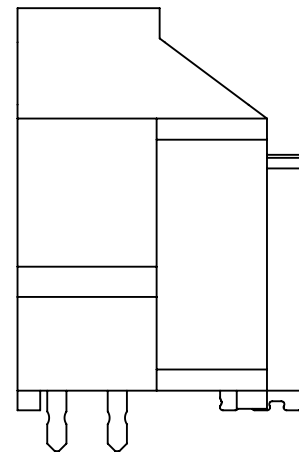
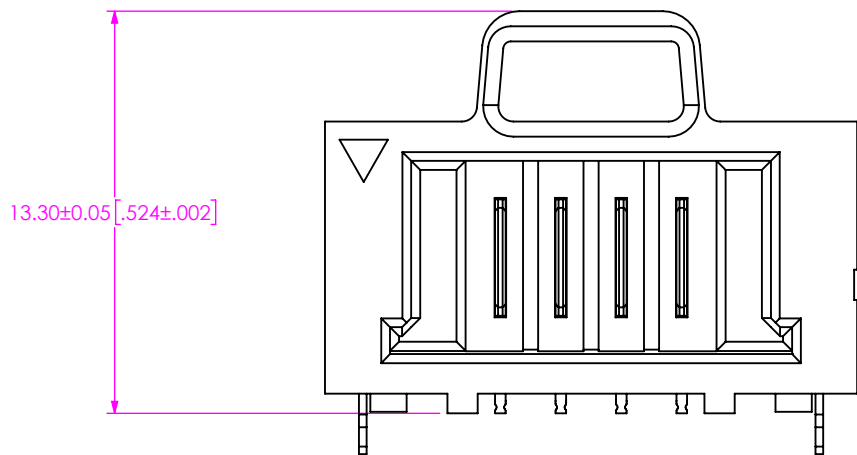

FIG 2
UMPT-04-01-XX-RA-WT-P SHOWN
(DIFFERENT AS SHOWN, OTHERWISE SAME AS FIG 1)

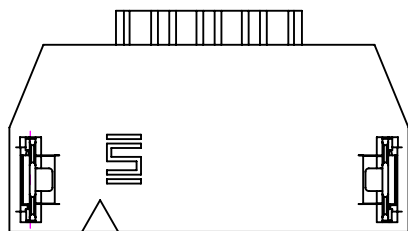

FIG 3
UMPT-04-01-XX-RA-WT-M SHOWN
(DIFFERENT AS SHOWN, OTHERWISE SAME AS FIG 1)

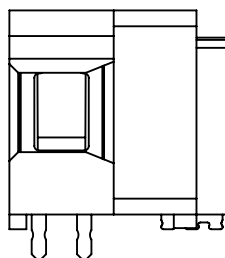
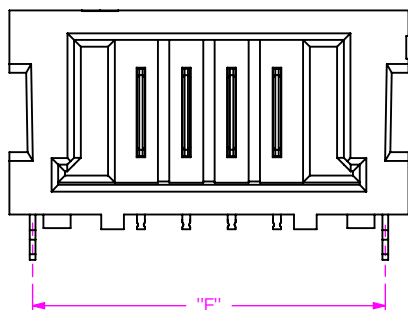

TABLE 2	
No. OF POS	"E"
-02	11.55 [.455]
-03	13.55 [.533]
-04	15.55 [.612]
-05	17.55 [.691]
-06	19.55 [.770]
-07	21.55 [.848]
-08	23.55 [.927]
-09	25.55 [1.006]
-10	27.55 [1.085]

PROPRIETARY NOTE
 THIS DOCUMENT CONTAINS CONFIDENTIAL AND PROPRIETARY INFORMATION AND ALL DESIGN, MANUFACTURING, REPRODUCTION, USE, PATENT RIGHTS AND SALES RIGHTS ARE EXPRESSLY RESERVED BY SAMTEC, INC. THIS DOCUMENT SHALL NOT BE DISCLOSED, IN WHOLE OR PART, TO ANY UNAUTHORIZED PERSON OR ENTITY NOR REPRODUCED, TRANSFERRED OR INCORPORATED IN ANY OTHER PROJECT IN ANY MANNER WITHOUT THE EXPRESS WRITTEN CONSENT OF SAMTEC, INC.

DO NOT SCALE DRAWING
 SHEET SCALE: 2:1

MATERIAL:
 INSULATOR: LCP
 TERMINAL: COPPER ALLOY
 WELD TAB: COPPER ALLOY



520 PARK EAST BLVD., NEW ALBANY, IN 47150
 PHONE: 812-944-6733 FAX: 812-948-5047
 e-Mail info@SAMTEC.com code 55322

DESCRIPTION:
 ULTRA MICRO POWER RA TERMINAL

DWG. NO.
 UMPT-XX-XX-XX-RA-WX-X-XR

BY: ETHAN C 06/12/2019 SHEET 2 OF 2