

DFC10 SERIES

SINGLE OUTPUT

DESCRIPTION

The DFC10 Series provides power converter solutions to meet commercial and industrial requirements. With power densities above 11 watts per cubic inch (0.67 watts per cm³), overcurrent protection, and five-sided shielded case, the DFC10 meets the most rigorous needs in an industry standard case size. The 220KHz operating frequency of the DFC10 Series allows an increased power density while including adequate heat sinking and input/output filtering. This eliminates the need for external components in most applications. Full overload protection is provided by pulse-by-pulse current limiting.

FEATURES

- High Power Density, up to 11 Watts per Cubic Inch (0.67 watts per cm³)
- Efficiencies to 83% (Lower for 3.3V)
- Low Input to Output Capacitance
- 700V Isolation(1544V for 48V Converters)
- Continuous Overcurrent Protection
- 3.3Volt Output Available
- Five-Side Shielded Copper Case
- Extended Input Range (2:1)

Selection Chart				
Model	Input Range VDC (4)		Output VDC	Output mA
	Min	Max		
DFC10E12S3.3	9	18	3.33	2000
DFC10E12S5	9	18	5	2000
DFC10E12S12	9	18	12	900
DFC10E12S15	9	18	15	700
DFC10E24S3.3	18	36	3.33	2000
DFC10E24S5	18	36	5	2000
DFC10E24S12	18	36	12	900
DFC10E24S15	18	36	15	700
DFC10E48S3.3	36	72	3.33	2000
DFC10E48S5	36	72	5	2000
DFC10E48S12	36	72	12	900
DFC10E48S15	36	72	15	700

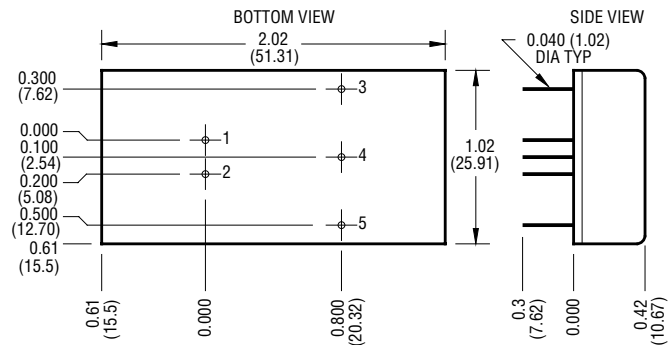

Mechanical tolerances unless otherwise noted:
 X.XX dimensions: ±0.020 inches
 X.XXX dimensions: ±0.005 inches

General Specifications (1)			
All Models			Units
Isolation (2)			
Isolation Voltage			
Input to Output 12V, 24V	MIN	700	VDC
Input to Output 48V	MIN	1544	
10 μA Leakage			
Input to Output Capacitance	TYP	400	pF
Environmental			
Case Operating Range, Tc	MIN	-40	° C
No Derating	MAX	90	
Case Functional Range (3)	MIN	-50	° C
	MAX	100	
Storage Range	MIN	-55	° C
	MAX	105	
Thermal Impedance (4)	TYP	15	° C/Watt
General			
MTBF (Calculated)	TYP	800,000	HRS
Unit Weight	TYP	1.0/28	oz/gm
Chassis Mounting Kit 12V, 24V		CM2B2	
Chassis Mounting Kit 48V		CM2A1	

Pin	Function
1	+INPUT
2	-INPUT
3	+OUT
4	NO PIN
5	-OUT

NOTES

- (1) All parameters measured at Tc = 25°C, nominal input voltage and full rated load unless otherwise noted. Refer to the DC/DC Technical Reference Section for the definition of terms, measurement circuits and other information.
- (2) The Case is tied to the -Input pin.
- (3) The functional temperature range is intended to give an additional data point for use in evaluating this power supply. At the low functional temperature the power supply will function with no side effects, however, sustained operation at the high functional temperature will reduce expected operational life. The data sheet specifications are not guaranteed beyond the case operating range.
- (4) The case thermal impedance is specified as the case temperature rise over ambient per package watt dissipated.

DFC10 SERIES – SINGLE OUTPUT

Input Parameters (1)								
Model		DFC10E12S3.3	DFC10E12S5	DFC10E12S12	DFC10E12S15	DFC10E24S3.3	DFC10E24S5	Units
Reflected Ripple (2)	TYP	280	440			140	210	mA_{PP}
	TYP	90	145			45	70	mA_{rms}
Input Current Full Load No Load	TYP	724	1070	1100	1060	344	500	mA
	TYP	7	7	12	15	7	7	
Efficiency	TYP	76	78	82	83	80	83	%
Switching Frequency	TYP	220						kHz
Maximum Input Overvoltage, 100ms Maximum	MAX	24				45		VDC
Turn-on Time, 1% Output Error	TYP	10						ms
Model		DFC10E24S12	DFC10E24S15	DFC10E48S3.3	DFC10E48S5	DFC10E48S12	DFC10E48S15	Units
Reflected Ripple (2)	TYP	210		100	150			mA_{PP}
	TYP	70		35	50			mA_{rms}
Input Current Full Load No Load	TYP	530	510	176	260	270	260	mA
	TYP	10	10	6	6	6	6	
Efficiency	TYP	85	86	78	81	83	84	%
Switching Frequency	TYP	220						kHz
Maximum Input Overvoltage, 100ms Maximum	MAX	45			85			VDC

Output Parameters (1)							
Model		DFC10E12S3.3 DFC10E24S3.3 DFC10E48S3.3	DFC10E12S5 DFC10E24S5 DFC10E48S5	DFC10E12S12 DFC10E24S12 DFC10E48S12	DFC10E12S15 DFC10E24S15 DFC10E48S15	Units	
Output Voltage		3.33		5	12	15	VDC
Output Voltage Accuracy	MIN	3.30		4.95	11.90	14.90	VDC
	TYP	3.33		5.00	12.00	15.00	
	MAX	3.36		5.05	12.10	15.10	
Rated Load Range	MIN	0.0		0.0	0.0	0.0	A
	MAX	2.0		2.0	0.9	0.7	
Load Regulation 25% Max Load - Max Load	TYP	0.1		0.1	0.2	0.2	%
	MAX	0.4		0.4	0.4	0.4	
Line Regulation $V_{\text{in}} = \text{Min-Max VDC}$	TYP	0.5		0.01	0.2	0.2	%
	MAX	1.0		0.2	0.8	0.8	
Short Term Stability (3)	TYP	< 0.05					%/24Hrs
Long Term Stability	TYP	< 0.1					%/kHrs
Input Ripple Rejection (4)	TYP	> 40					dB
Noise, Peak - Peak (2)	TYP	60					mV_{PP}
RMS Noise	TYP	6					mV_{rms}
Temperature Coefficient	TYP	50					ppm/°C
	MAX	150					
Short Circuit Protection from +OUT to -OUT		Continuous, Current Limit Protection					

NOTES

- (1) All parameters measured at $T_c = 25^\circ\text{C}$, nominal input voltage and full rated load unless otherwise noted. Refer to the DC/DC Technical Reference Section for the definition of terms, measurement circuits and other information.
- (2) Noise is measured per DC/DC Technical Reference Section. Measurement bandwidth is 0-20 MHz for peak-peak measurements, 10 kHz to 1 MHz for RMS measurements. Output noise is measured with a $0.01\mu\text{F} / 100\text{V}$ ceramic capacitor in parallel with a $1\mu\text{F} / 35\text{V}$ Tantalum capacitor, 1 inch from the output pins to simulate standard PCB decoupling capacitance.
- (3) Short term stability is specified after a 30 minute warmup at full load, constant line and recording the drift over a 24 hour period.
- (4) The input ripple rejection is specified for DC to 120 Hz ripple with a modulation amplitude of 1% of V_{in} .

DFC10 SERIES APPLICATION NOTES:

External Capacitance Requirements

No external capacitance is required for operation of the DFC10 Series. If a capacitive input source is farther than 1" from the converter, an additional capacitor may be required at the input pins for proper operation. This input capacitor should have an ESR

greater than 0.25 ohms. Input capacitors with an ESR less than 0.25 ohms may cause peaking of the input filter and actually degrade circuit performance.

External output capacitance is not required for operation, however it is recommended that $1\mu\text{F}$ to $10\mu\text{F}$ of tantalum and 0.001 to $0.1\mu\text{F}$ ceramic capacitance be selected for reduced system noise. Additional output capacitance may be added for increased filtering, but should not exceed $400\mu\text{F}$.

Negative Outputs

A negative output voltage may be obtained by connecting the +OUT to circuit ground and connecting -OUT as the negative output.

DFC10 SERIES – SINGLE OUTPUT

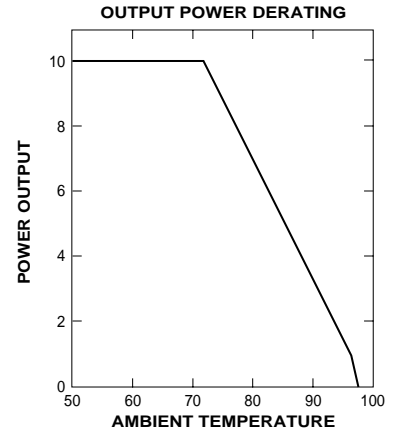
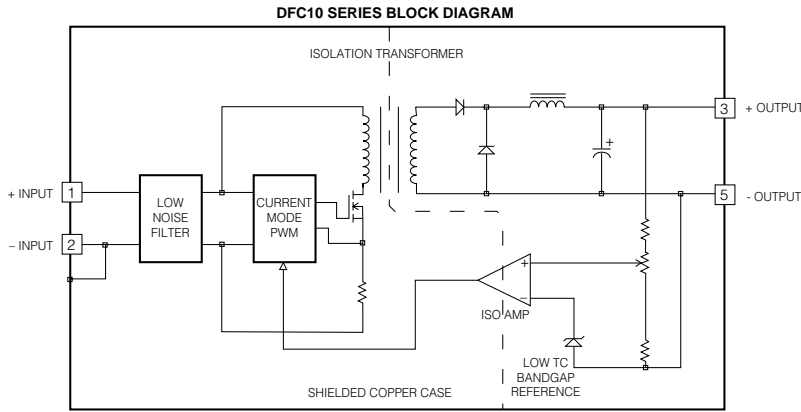

Typical Performance: (Tc=25°C, Vin=Nom VDC, Rated Load)

Data for 12 Volt Input Models

12 VOLT INPUT CURRENT Vs. LINE INPUT VOLTAGE

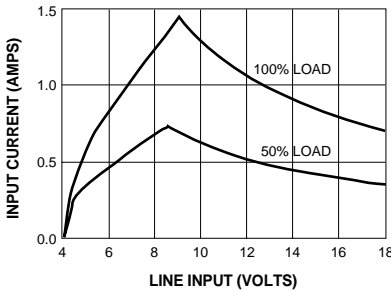

12 VOLT EFFICIENCY Vs. LOAD

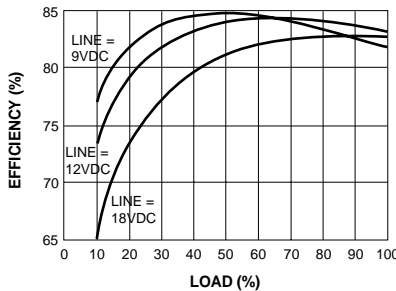

12 VOLT EFFICIENCY Vs. LINE INPUT VOLTAGE

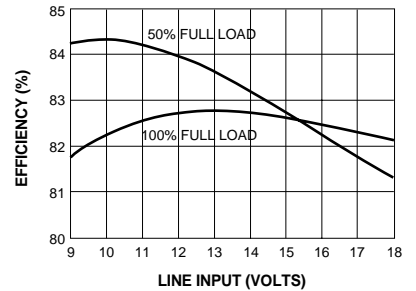

Data for 24 Volt Input Models

24 VOLT INPUT CURRENT Vs. LINE INPUT VOLTAGE

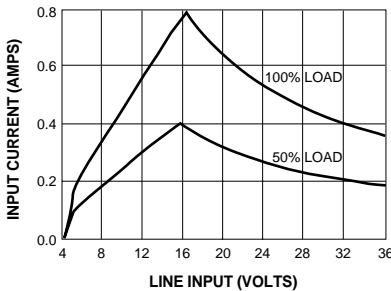

24 VOLT EFFICIENCY Vs. LOAD

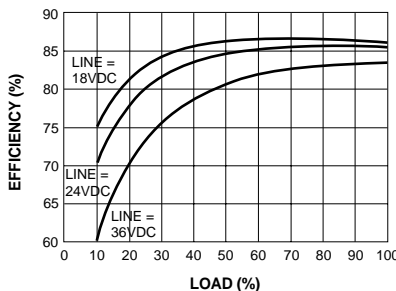

24 VOLT EFFICIENCY Vs. LINE INPUT VOLTAGE

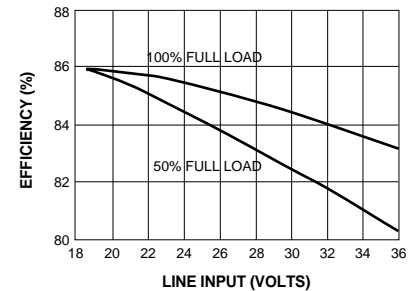

Data for 48 Volt Input Models

48 VOLT INPUT CURRENT Vs. LINE INPUT VOLTAGE

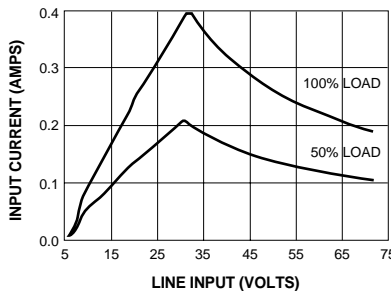

48 VOLT EFFICIENCY Vs. LOAD

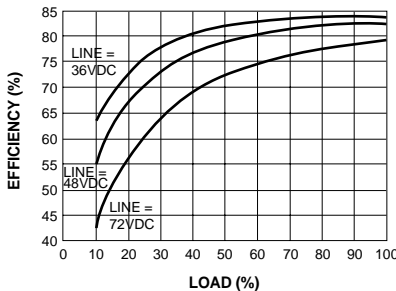

48 VOLT EFFICIENCY Vs. LINE INPUT VOLTAGE

