

32-Channel Vacuum Fluorescent Display Driver

Features

- Thirty-two Output Lines
- 90V Output Swing
- Active Pull-down
- Latches on all Outputs
- Up to 6 MHz at $V_{DD} = 5V$
- $-40^{\circ}C$ to $+85^{\circ}C$ Operation

Applications

- Vacuum Fluorescent Displays
- DC Plasma Displays

General Description

The HV518 is designed for vacuum fluorescent or DC plasma applications where it can serve as a segment, digit or matrix display driver. Each device has 32 outputs, 32 latches and a 32-bit cascadable Shift register.

Serial data enters the Shift register on the low-to-high transition of the clock input. With latch enable (\overline{LE}) high, parallel data is transferred to the output buffers through a 32-bit latch. When \overline{LE} is low, the data is stored in the latch. When strobe (STR) is low, all outputs are enabled. If the strobe is high, all outputs are low.

Package Types

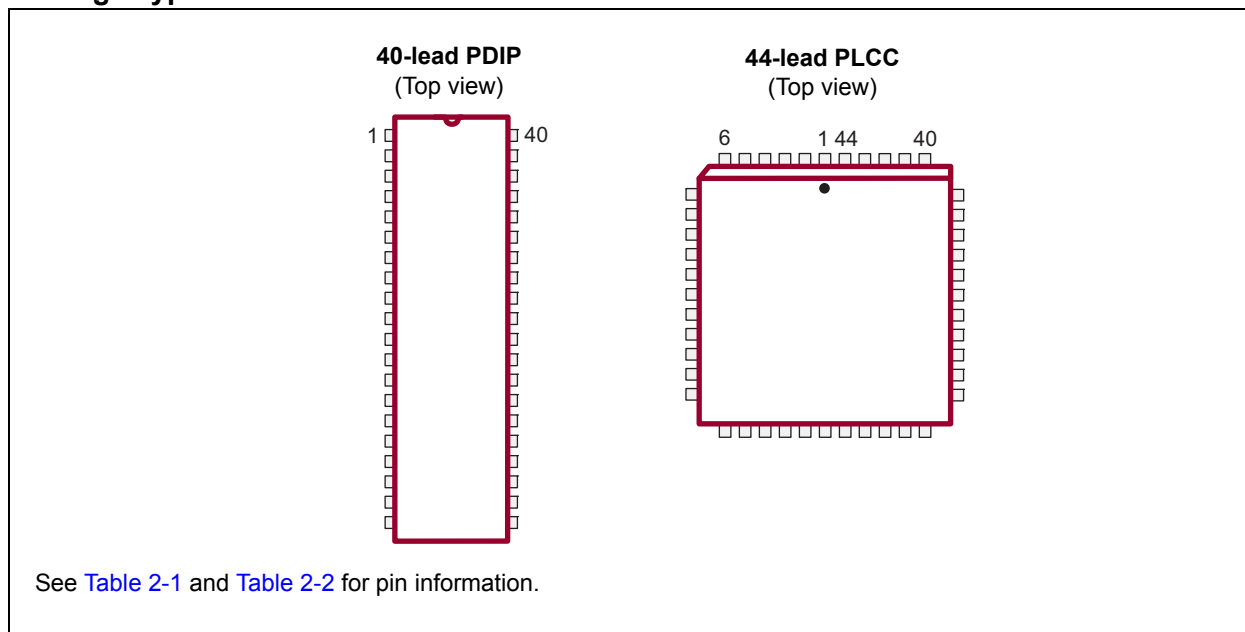

HV518

Functional Block Diagram

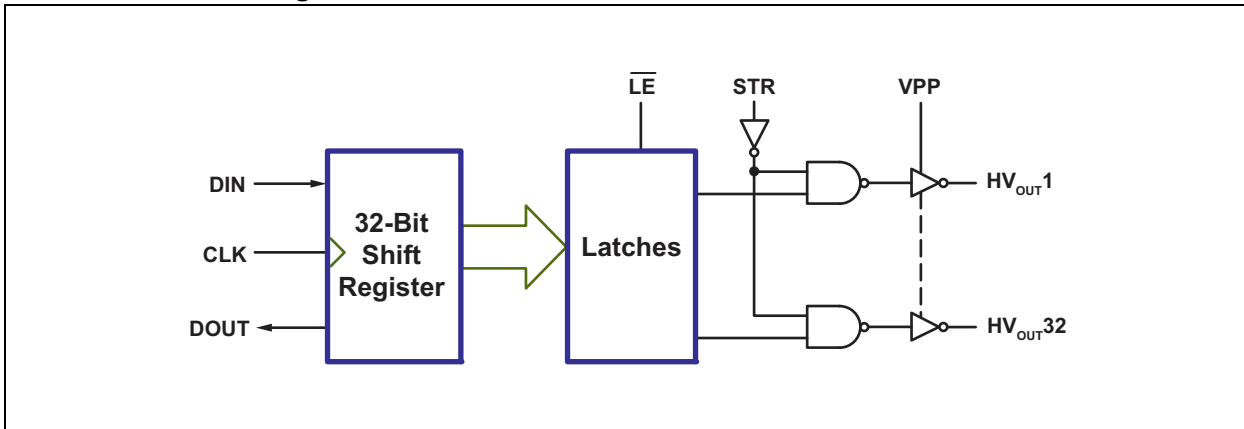

Typical Application Circuit

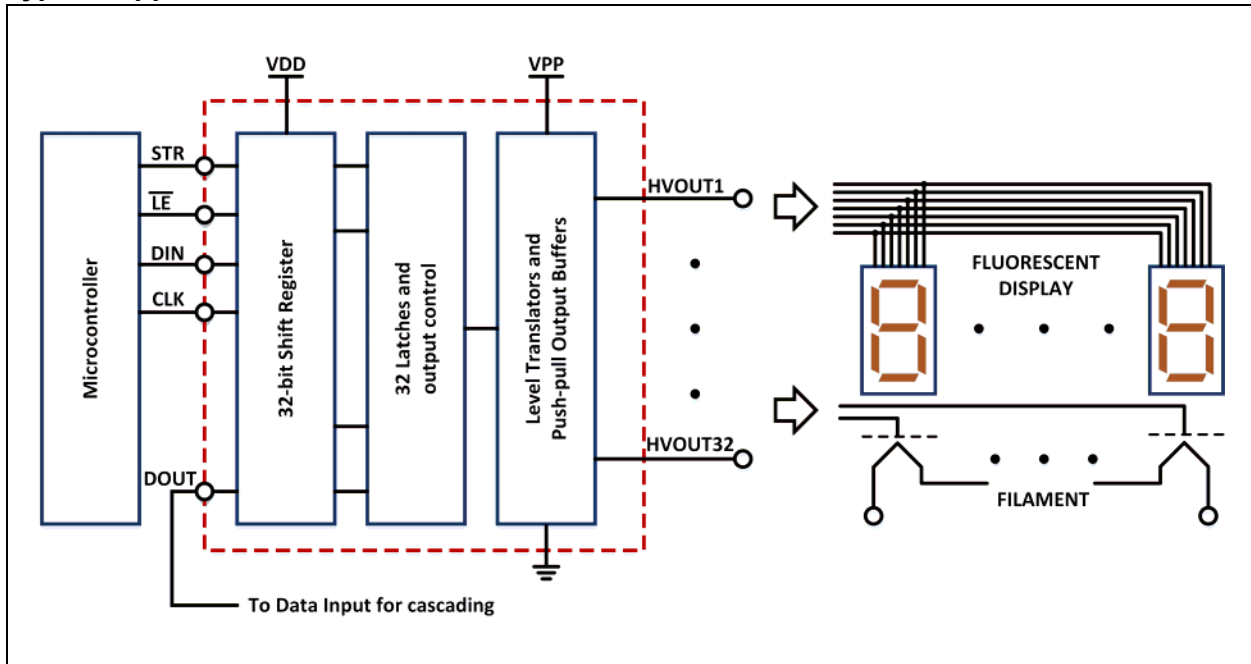

HV518

1.0 ELECTRICAL CHARACTERISTICS

Absolute Maximum Ratings†

Low-voltage Supply Voltage, V_{DD}	-0.5V to +6V
High-voltage Supply Voltage, V_{PP}	-0.5V to +90V
Logic Input Levels	-0.5V to $V_{DD}+0.5V$
Operating Ambient Temperature, T_A	-40°C to +85°C
Storage Temperature, T_S	-65°C to +150°C
Continuous Total Power Dissipation:	
40-lead PDIP (Note 1 , Note 2)	1200 mW
44-lead PLCC (Note 1 , Note 2)	1200 mW

† **Notice:** Stresses above those listed under “Absolute Maximum Ratings” may cause permanent damage to the device. This is a stress rating only, and functional operation of the device at those or any other conditions above those indicated in the operational sections of this specification is not intended. Exposure to maximum rating conditions for extended periods may affect device reliability.

- Note 1:** Duty cycle is limited by the total power dissipated in the package.
Note 2: For operations above 25°C ambient, derate linearly to 85°C at 20 mW/°C.

RECOMMENDED OPERATING CONDITIONS

Electrical Specifications: $T_A = 25^\circ\text{C}$ unless otherwise indicated.						
Parameter	Sym.	Min.	Typ.	Max.	Unit	Conditions
Logic Supply Voltage	V_{DD}	4.5	—	5.5	V	
High-voltage Supply Voltage	V_{PP}	8	—	80	V	
High-level Input Voltage	V_{IH}	3.5	—	—	V	$V_{DD} = 4.5V$ (See Figure 3-1.)
Low-level Input Voltage	V_{IL}	—	—	1	V	$V_{DD} = 4.5V$ (See Figure 3-1.)
High-level Output Current	I_{OH}	-25	—	—	mA	
Low-level Output Current	I_{OL}	—	—	2	mA	
Clock Frequency	f_{CLK}	—	—	6	MHz	$V_{DD} = 4.5V$ (See Figure 3-1.)
Pulse Duration, Clock High	$t_{W(CKH)}$	83	—	—	ns	$V_{DD} = 4.5V$
Pulse Duration, Clock Low	$t_{W(CKL)}$	83	—	—	ns	$V_{DD} = 4.5V$
Setup Time, Data before Clock	t_{SU}	75	—	—	ns	$V_{DD} = 4.5V$
Hold Time, Data after Clock	t_H	75	—	—	ns	$V_{DD} = 4.5V$
Operating Ambient Temperature	T_A	-40	—	+85	°C	

ELECTRICAL CHARACTERISTICS

Electrical Specifications: Over recommended operating conditions unless otherwise indicated							
Parameter		Sym.	Min.	Typ.	Max.	Unit	Conditions
Supply Current		I_{DD}	—	—	10	mA	$V_{DD} = 5V, f_{CH} = 6 \text{ MHz}$
Quiescent Supply Current		I_{DDQ}	—	—	0.5	mA	$V_{DD} = 5.5V, V_{IN} = 0V$
Supply Current		I_{PP}	—	—	12	mA	Outputs high, $T_A = -40^\circ\text{C}$
			—	7	10	mA	Outputs high, $T_A = 0^\circ\text{C}$ to $+85^\circ\text{C}$
			—	—	500	μA	Outputs low
HV _{IN} Operating Current	HV Output	V_{OH}	70	—	—	V	$I_{OH} = -25\text{mA}$
	Serial Output		4.5	4.9	5	V	$V_{DD} = 5V, I_{OH} = -20 \mu\text{A}$
LV _{IN} Operating Current	HV Output	V_{OL}	—	—	5	V	$I_{OL} = 1 \text{ mA}$
	Serial Output		—	0.06	0.8	V	$I_{OL} = 20 \mu\text{A}$
Logic Input Current High		I_{IH}	—	0.1	1	μA	$V_{IH} = V_{DD}$
Logic Input Current Low		I_{IL}	—	-0.1	-1	μA	$V_{IL} = 0V$

Note 1: The power dissipation is determined by the number of output at ON state and their duty cycles. The total power must not exceed the allowable package power dissipation.

SWITCHING CHARACTERISTICS

Electrical Specifications: $V_{PP} = 80V, C_L = 50 \text{ pF}$ and $T_A = 25^\circ\text{C}$ unless otherwise noted.							
Parameter		Sym.	Min.	Typ.	Max.	Unit	Conditions
Delay Time, Clock-to-data Output		t_d	—	—	600	ns	$C_L = 15 \text{ pF}$ (See Figure 3-2.)
Delay Time, High-to-low Level, HV Output	From Latch Enable	t_{DHL}	—	—	1.5	μs	$V_{DD} = 4.5V$ (See Figure 3-3.)
	From Strobe		—	—	1	μs	$V_{DD} = 4.5V$ (See Figure 3-4.)
Delay Time, Low-to-high Level, HV Output	From Latch Enable	t_{DLH}	—	—	1.5	μs	$V_{DD} = 4.5V$ (See Figure 3-3.)
	From Strobe		—	—	1	μs	$V_{DD} = 4.5V$ (See Figure 3-4.)
Transition Time, High-to-low Level, HV Output		t_{THL}	—	—	3	μs	$V_{DD} = 4.5V$ (See Figure 3-4.)
Transition Time, Low-to-high Level, HV Output		t_{TLH}	—	—	2.5	μs	$V_{DD} = 4.5V$ (See Figure 3-4.)

TEMPERATURE SPECIFICATIONS

Parameter	Sym.	Min.	Typ.	Max.	Unit	Conditions
TEMPERATURE RANGE						
Operating Ambient Temperature	T_A	-40	—	+85	$^\circ\text{C}$	
Storage Temperature	T_S	-65	—	+150	$^\circ\text{C}$	
PACKAGE THERMAL RESISTANCE						
40-lead PDIP	θ_{JA}	—	39	—	$^\circ\text{C/W}$	
44-lead PLCC	θ_{JA}	—	37	—	$^\circ\text{C/W}$	

HV518

Timing Waveforms

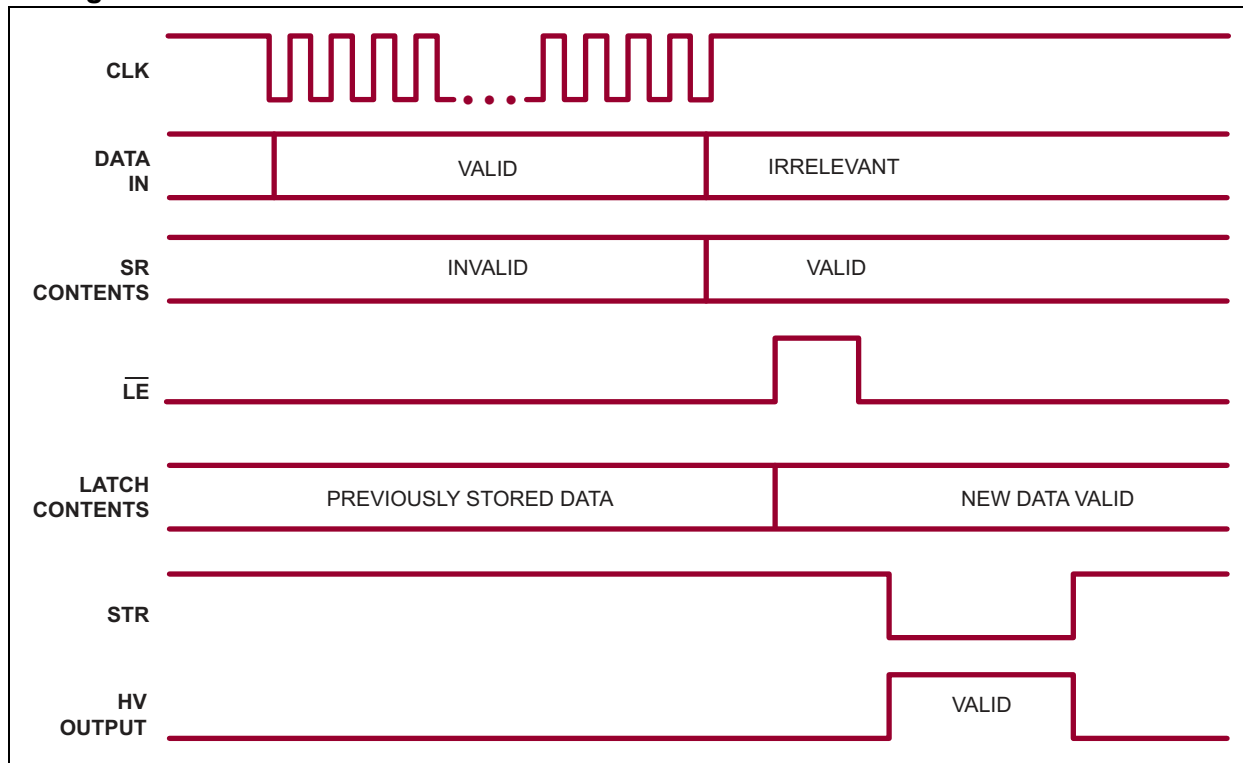

2.0 PIN DESCRIPTION

The details on the pins of HV518 40-lead PDIP and 44-lead PLCC are listed on [Table 2-1](#) and [Table 2-2](#), respectively. Refer to [Package Types](#) for the location of pins.

TABLE 2-1: 40-LEAD PDIP PIN FUNCTION TABLE

Pin Number	Pin Name	Description
1	VPP	High-voltage power supply
2	SERIAL OUT	Serial data output
3	HVOUT32	High-voltage output
4	HVOUT31	High-voltage output
5	HVOUT30	High-voltage output
6	HVOUT29	High-voltage output
7	HVOUT28	High-voltage output
8	HVOUT27	High-voltage output
9	HVOUT26	High-voltage output
10	HVOUT25	High-voltage output
11	HVOUT24	High-voltage output
12	HVOUT23	High-voltage output
13	HVOUT22	High-voltage output
14	HVOUT21	High-voltage output
15	HVOUT20	High-voltage output
16	HVOUT19	High-voltage output
17	HVOUT18	High-voltage output
18	HVOUT17	High-voltage output
19	STR	Strobe
20	GND	Ground
21	CLK	Data Shift register clock. Inputs are shifted into the Shift register on the positive edge of the clock.
22	\overline{LE}	Latch enable
23	HVOUT16	High-voltage output
24	HVOUT15	High-voltage output
25	HVOUT14	High-voltage output
26	HVOUT13	High-voltage output
27	HVOUT12	High-voltage output
28	HVOUT11	High-voltage output
29	HVOUT10	High-voltage output
30	HVOUT9	High-voltage output
31	HVOUT8	High-voltage output
32	HVOUT7	High-voltage output
33	HVOUT6	High-voltage output

HV518

TABLE 2-1: 40-LEAD PDIP PIN FUNCTION TABLE (CONTINUED)

Pin Number	Pin Name	Description
34	HVOUT5	High-voltage output
35	HVOUT4	High-voltage output
36	HVOUT3	High-voltage output
37	HVOUT2	High-voltage output
38	HVOUT1	High-voltage output
39	DATA IN	Serial data input
40	VDD	Low-voltage power supply

TABLE 2-2: 44-LEAD PLCC PIN FUNCTION TABLE

Pin Number	Pin Name	Description
1	VPP	High-voltage power supply
2	SERIAL OUT	Serial data output
3	HVOUT32	High-voltage output
4	HVOUT31	High-voltage output
5	HVOUT30	High-voltage output
6	NC	No connection
7	HVOUT29	High-voltage output
8	HVOUT28	High-voltage output
9	HVOUT27	High-voltage output
10	HVOUT26	High-voltage output
11	HVOUT25	High-voltage output
12	HVOUT24	High-voltage output
13	HVOUT23	High-voltage output
14	HVOUT22	High-voltage output
15	HVOUT21	High-voltage output
16	HVOUT20	High-voltage output
17	HVOUT19	High-voltage output
18	NC	No connection
19	HVOUT18	High-voltage output
20	HVOUT17	High-voltage output
21	STR	Strobe
22	GND	Ground
23	CLK	Data Shift register clock. Inputs are shifted into the Shift register on the positive edge of the clock.
24	$\overline{\text{LE}}$	Latch enable
25	HVOUT16	High-voltage output
26	HVOUT15	High-voltage output
27	HVOUT14	High-voltage output
28	NC	No connection

TABLE 2-2: 44-LEAD PLCC PIN FUNCTION TABLE (CONTINUED)

Pin Number	Pin Name	Description
29	NC	No connection
30	HVOUT13	High-voltage output
31	HVOUT12	High-voltage output
32	HVOUT11	High-voltage output
33	HVOUT10	High-voltage output
34	HVOUT9	High-voltage output
35	HVOUT8	High-voltage output
36	HVOUT7	High-voltage output
37	HVOUT6	High-voltage output
38	HVOUT5	High-voltage output
39	HVOUT4	High-voltage output
40	HVOUT3	High-voltage output
41	HVOUT2	High-voltage output
42	HVOUT1	High-voltage output
43	DATA IN	Serial data input
44	VDD	Low-voltage power supply

3.0 FUNCTIONAL DESCRIPTION

3.1 Parameter Measurement Information

Figure 3-1 to Figure 3-4 show parametric measurement information. For testing purposes, all input pulses have maximum rise and fall times of 30 nanoseconds.

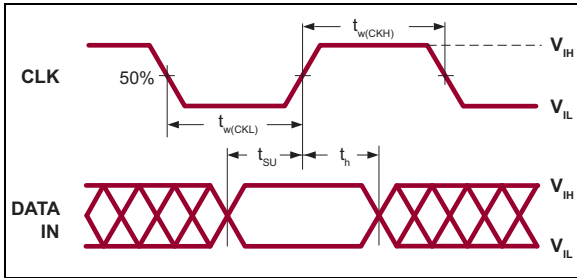

FIGURE 3-1: Input Timing Voltage Waveforms.

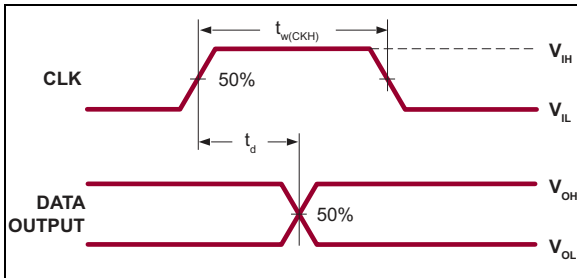

FIGURE 3-2: Output Timing Voltage Waveforms.

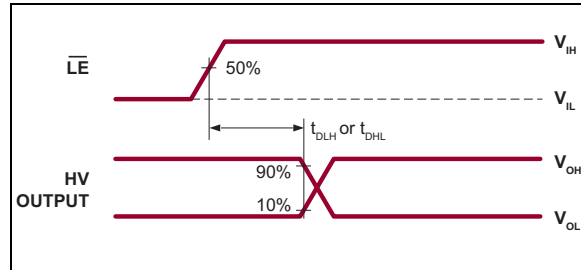

FIGURE 3-3: Latch Enable Timing Voltage Waveforms.

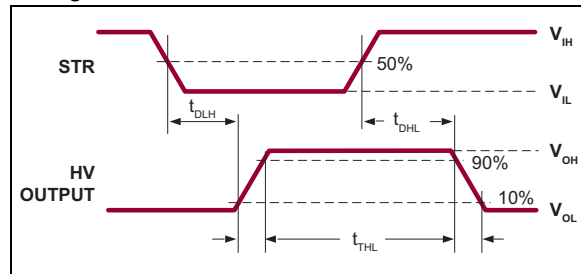

FIGURE 3-4: Switching-Time Voltage Waveforms.

3.2 Power-up and Power-down Sequence

Follow the steps below to power up and power down the HV518:

TABLE 3-1: POWER-UP AND POWER-DOWN SEQUENCE

Power-up		Power-down	
Step	Description	Step	Description
1	Connect ground.	1	Remove V_{PP} . (Note 1)
2	Apply V_{DD} .	2	Remove all inputs.
3	Set all inputs (Data, CLK, EN, etc.) to a known state.	3	Remove V_{DD} .
4	Apply V_{PP} . (Note 1)	4	Disconnect ground.

Note 1: The V_{PP} should not drop below V_{DD} during operation.

TABLE 3-2: TRUTH FUNCTION TABLE

Inputs			Outputs			
Data In	CLK	Data Out	Data In	\overline{LE}	STR	High-voltage Output
H		H	X	X	H	All low
L		L	H	H	L	High
X	No change	Previous state	L	H	L	Low
			X	L	L	Previous state

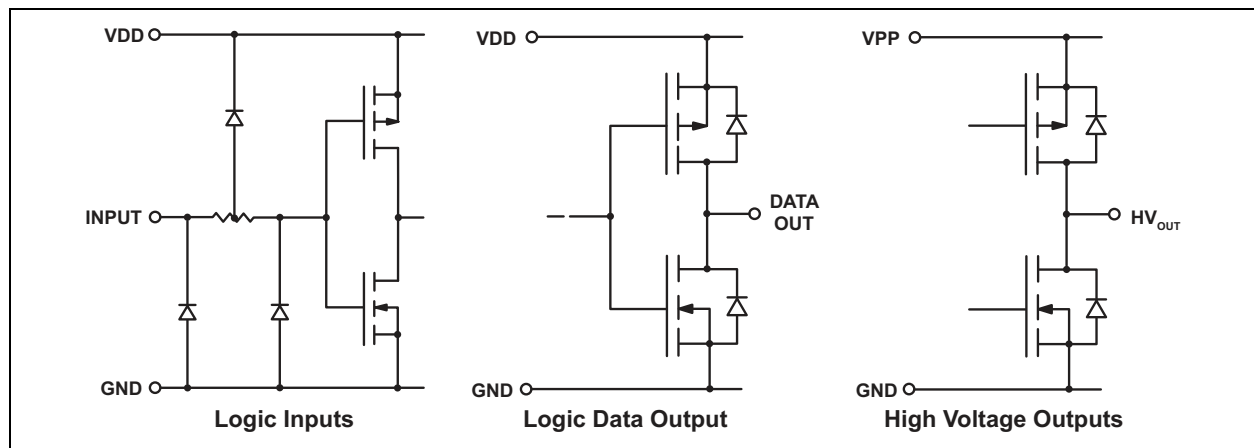
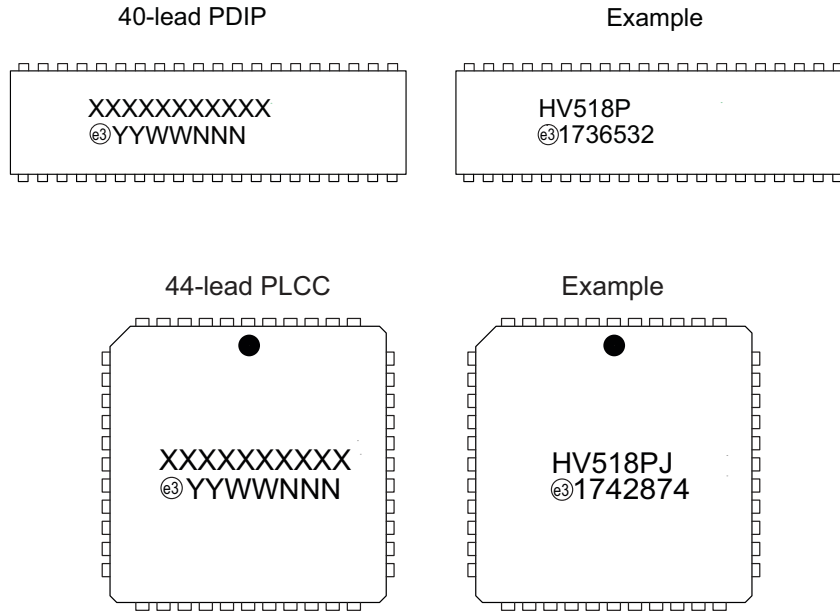

FIGURE 3-5: Input and Output Equivalent Circuits.

HV518

4.0 PACKAGE MARKING INFORMATION

4.1 Packaging Information



Legend:	XX...X	Product Code or Customer-specific information
	Y	Year code (last digit of calendar year)
	YY	Year code (last 2 digits of calendar year)
	WW	Week code (week of January 1 is week '01')
	NNN	Alphanumeric traceability code
	Ⓔ	Pb-free JEDEC [®] designator for Matte Tin (Sn)
	*	This package is Pb-free. The Pb-free JEDEC designator (Ⓔ) can be found on the outer packaging for this package.
Note:	In the event the full Microchip part number cannot be marked on one line, it will be carried over to the next line, thus limiting the number of available characters for product code or customer-specific information. Package may or not include the corporate logo.	

40-Lead PDIP (.600in Row Spacing) Package Outline (P) 2.095x.580in body (max), .250in height (max), .100in pitch

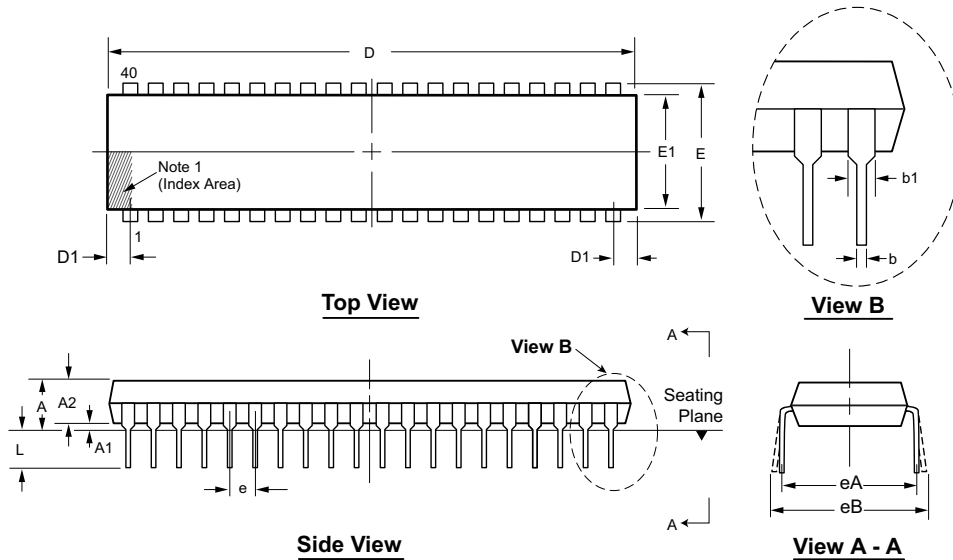

Note: For the most current package drawings, see the Microchip Packaging Specification at www.microchip.com/packaging.

Note:

1. A Pin 1 identifier must be located in the index area indicated. The Pin 1 identifier can be: a molded mark/identifier; an embedded metal marker; or a printed indicator.

Symbol	A	A1	A2	b	b1	D	D1	E	E1	e	eA	eB	L	
Dimension (inches)	MIN	.140*	.015	.125	.014	.030	1.980	.065 [†]	.590 [†]	.485	.100 BSC	.600 BSC	.600*	.115
	NOM	-	-	-	-	-	-	-	-	-			-	-
	MAX	.250	.055*	.195	.023 [†]	.070	2.095	.085*	.625	.580			.700	.200

JEDEC Registration MS-011, Variation AC, Issue B, June, 1988.

* This dimension is not specified in the JEDEC drawing.

† This dimension differs from the JEDEC drawing.

Drawings not to scale.

44-Lead PLCC Package Outline (PJ) .653x.653in body, .180in height (max), .050in pitch

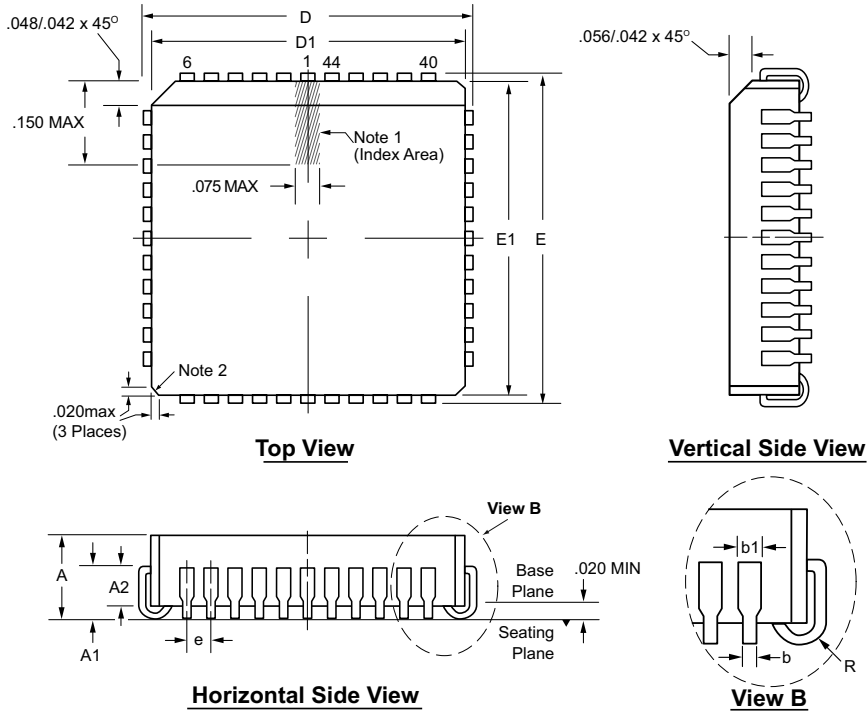

Note: For the most current package drawings, see the Microchip Packaging Specification at www.microchip.com/packaging.

Notes:

1. A Pin 1 identifier must be located in the index area indicated. The Pin 1 identifier can be: a molded mark/identifier; an embedded metal marker; or a printed indicator.
2. Actual shape of this feature may vary.

Symbol	A	A1	A2	b	b1	D	D1	E	E1	e	R
Dimension (inches)	MIN	.165	.090	.062	.013	.026	.685	.650	.685	.650	.025
	NOM	.172	.105	-	-	-	.690	.653	.690	.653	.035
	MAX	.180	.120	.083	.021	.036 [†]	.695	.656	.695	.656	.045

JEDEC Registration MS-018, Variation AC, Issue A, June, 1993.

[†] This dimension differs from the JEDEC drawing.

Drawings not to scale.

APPENDIX A: REVISION HISTORY

Revision A (October 2017)

- Converted Supertex Doc# DSFP-HV518 to Microchip DS20005847A
- Changed the package marking format
- Made minor text changes throughout the document

HV518

PRODUCT IDENTIFICATION SYSTEM

To order or obtain information, e.g., on pricing or delivery, contact your local Microchip representative or sales office.

<u>PART NO.</u>	<u>XX</u>	-	<u>X</u>	-	<u>X</u>
Device	Package Options		Environmental		Media Type
Device:	HV518	=	32-Channel Vacuum Fluorescent Display Driver		
Packages:	P	=	40-lead PDIP		
	PJ	=	44-lead PLCC		
Environmental:	G	=	Lead (Pb)-free/RoHS-compliant Package		
Media Types:	(blank)	=	9/Tube for a P Package		
	(blank)	=	27/Tube for a PJ Package		
	M903	=	500/Reel for a PJ Package		

Examples:

a) HV518P-G: 32-Channel Vacuum Fluorescent Display Driver, 40-lead PDIP, 9/Tube

b) HV518PJ-G: 32-Channel Vacuum Fluorescent Display Driver, 44-lead PLCC, 27/Tube

c) HV518PJ-G-M903: 32-Channel Vacuum Fluorescent Display Driver, 44-lead PLCC, 500/Reel

Note the following details of the code protection feature on Microchip devices:

- Microchip products meet the specification contained in their particular Microchip Data Sheet.
- Microchip believes that its family of products is one of the most secure families of its kind on the market today, when used in the intended manner and under normal conditions.
- There are dishonest and possibly illegal methods used to breach the code protection feature. All of these methods, to our knowledge, require using the Microchip products in a manner outside the operating specifications contained in Microchip's Data Sheets. Most likely, the person doing so is engaged in theft of intellectual property.
- Microchip is willing to work with the customer who is concerned about the integrity of their code.
- Neither Microchip nor any other semiconductor manufacturer can guarantee the security of their code. Code protection does not mean that we are guaranteeing the product as “unbreakable.”

Code protection is constantly evolving. We at Microchip are committed to continuously improving the code protection features of our products. Attempts to break Microchip's code protection feature may be a violation of the Digital Millennium Copyright Act. If such acts allow unauthorized access to your software or other copyrighted work, you may have a right to sue for relief under that Act.

Information contained in this publication regarding device applications and the like is provided only for your convenience and may be superseded by updates. It is your responsibility to ensure that your application meets with your specifications. MICROCHIP MAKES NO REPRESENTATIONS OR WARRANTIES OF ANY KIND WHETHER EXPRESS OR IMPLIED, WRITTEN OR ORAL, STATUTORY OR OTHERWISE, RELATED TO THE INFORMATION, INCLUDING BUT NOT LIMITED TO ITS CONDITION, QUALITY, PERFORMANCE, MERCHANTABILITY OR FITNESS FOR PURPOSE. Microchip disclaims all liability arising from this information and its use. Use of Microchip devices in life support and/or safety applications is entirely at the buyer's risk, and the buyer agrees to defend, indemnify and hold harmless Microchip from any and all damages, claims, suits, or expenses resulting from such use. No licenses are conveyed, implicitly or otherwise, under any Microchip intellectual property rights unless otherwise stated.

Microchip received ISO/TS-16949:2009 certification for its worldwide headquarters, design and wafer fabrication facilities in Chandler and Tempe, Arizona; Gresham, Oregon and design centers in California and India. The Company's quality system processes and procedures are for its PIC® MCUs and dsPIC® DSCs, KEELOQ® code hopping devices, Serial EEPROMs, microperipherals, nonvolatile memory and analog products. In addition, Microchip's quality system for the design and manufacture of development systems is ISO 9001:2000 certified.

**QUALITY MANAGEMENT SYSTEM
CERTIFIED BY DNV
= ISO/TS 16949 =**

Trademarks

The Microchip name and logo, the Microchip logo, AnyRate, AVR, AVR logo, AVR Freaks, BeaconThings, BitCloud, CryptoMemory, CryptoRF, dsPIC, FlashFlex, flexPWR, Heldo, JukeBlox, KEELOQ, KEELOQ logo, Klear, LANCheck, LINK MD, maXStylus, maXTouch, MediaLB, megaAVR, MOST, MOST logo, MPLAB, OptoLyzer, PIC, picoPower, PICSTART, PIC32 logo, Prochip Designer, QTouch, RightTouch, SAM-BA, SpyNIC, SST, SST Logo, SuperFlash, tinyAVR, UNI/O, and XMEGA are registered trademarks of Microchip Technology Incorporated in the U.S.A. and other countries.

ClockWorks, The Embedded Control Solutions Company, EtherSynch, Hyper Speed Control, HyperLight Load, IntelliMOS, mTouch, Precision Edge, and Quiet-Wire are registered trademarks of Microchip Technology Incorporated in the U.S.A.

Adjacent Key Suppression, AKS, Analog-for-the-Digital Age, Any Capacitor, AnyIn, AnyOut, BodyCom, chipKIT, chipKIT logo, CodeGuard, CryptoAuthentication, CryptoCompanion, CryptoController, dsPICDEM, dsPICDEM.net, Dynamic Average Matching, DAM, ECAN, EtherGREEN, In-Circuit Serial Programming, ICSP, Inter-Chip Connectivity, JitterBlocker, KlearNet, KlearNet logo, Mindi, MiWi, motorBench, MPASM, MPF, MPLAB Certified logo, MPLIB, MPLINK, MultiTRAK, NetDetach, Omniscient Code Generation, PICDEM, PICDEM.net, PICKit, PICTail, PureSilicon, QMatrix, RightTouch logo, REAL ICE, Ripple Blocker, SAM-ICE, Serial Quad I/O, SMART-I.S., SQI, SuperSwitcher, SuperSwitcher II, Total Endurance, TSHARC, USBCheck, VariSense, ViewSpan, WiperLock, Wireless DNA, and ZENA are trademarks of Microchip Technology Incorporated in the U.S.A. and other countries.

SQTP is a service mark of Microchip Technology Incorporated in the U.S.A.

Silicon Storage Technology is a registered trademark of Microchip Technology Inc. in other countries.

GestIC is a registered trademark of Microchip Technology Germany II GmbH & Co. KG, a subsidiary of Microchip Technology Inc., in other countries.

All other trademarks mentioned herein are property of their respective companies.

© 2017, Microchip Technology Incorporated, All Rights Reserved.
ISBN: 978-1-5224-2265-5



MICROCHIP

Worldwide Sales and Service

AMERICAS

Corporate Office
2355 West Chandler Blvd.
Chandler, AZ 85224-6199
Tel: 480-792-7200
Fax: 480-792-7277
Technical Support:
<http://www.microchip.com/support>
Web Address:
www.microchip.com

Atlanta
Duluth, GA
Tel: 678-957-9614
Fax: 678-957-1455

Austin, TX
Tel: 512-257-3370

Boston
Westborough, MA
Tel: 774-760-0087
Fax: 774-760-0088

Chicago
Itasca, IL
Tel: 630-285-0071
Fax: 630-285-0075

Dallas
Addison, TX
Tel: 972-818-7423
Fax: 972-818-2924

Detroit
Novi, MI
Tel: 248-848-4000

Houston, TX
Tel: 281-894-5983

Indianapolis
Noblesville, IN
Tel: 317-773-8323
Fax: 317-773-5453
Tel: 317-536-2380

Los Angeles
Mission Viejo, CA
Tel: 949-462-9523
Fax: 949-462-9608
Tel: 951-273-7800

Raleigh, NC
Tel: 919-844-7510

New York, NY
Tel: 631-435-6000

San Jose, CA
Tel: 408-735-9110
Tel: 408-436-4270

Canada - Toronto
Tel: 905-695-1980
Fax: 905-695-2078

ASIA/PACIFIC

Asia Pacific Office
Suites 3707-14, 37th Floor
Tower 6, The Gateway
Harbour City, Kowloon

Hong Kong
Tel: 852-2943-5100
Fax: 852-2401-3431

Australia - Sydney
Tel: 61-2-9868-6733
Fax: 61-2-9868-6755

China - Beijing
Tel: 86-10-8569-7000
Fax: 86-10-8528-2104

China - Chengdu
Tel: 86-28-8665-5511
Fax: 86-28-8665-7889

China - Chongqing
Tel: 86-23-8980-9588
Fax: 86-23-8980-9500

China - Dongguan
Tel: 86-769-8702-9880

China - Guangzhou
Tel: 86-20-8755-8029

China - Hangzhou
Tel: 86-571-8792-8115
Fax: 86-571-8792-8116

China - Hong Kong SAR
Tel: 852-2943-5100
Fax: 852-2401-3431

China - Nanjing
Tel: 86-25-8473-2460
Fax: 86-25-8473-2470

China - Qingdao
Tel: 86-532-8502-7355
Fax: 86-532-8502-7205

China - Shanghai
Tel: 86-21-3326-8000
Fax: 86-21-3326-8021

China - Shenyang
Tel: 86-24-2334-2829
Fax: 86-24-2334-2393

China - Shenzhen
Tel: 86-755-8864-2200
Fax: 86-755-8203-1760

China - Wuhan
Tel: 86-27-5980-5300
Fax: 86-27-5980-5118

China - Xian
Tel: 86-29-8833-7252
Fax: 86-29-8833-7256

ASIA/PACIFIC

China - Xiamen
Tel: 86-592-2388138
Fax: 86-592-2388130

China - Zhuhai
Tel: 86-756-3210040
Fax: 86-756-3210049

India - Bangalore
Tel: 91-80-3090-4444
Fax: 91-80-3090-4123

India - New Delhi
Tel: 91-11-4160-8631
Fax: 91-11-4160-8632

India - Pune
Tel: 91-20-3019-1500

Japan - Osaka
Tel: 81-6-6152-7160
Fax: 81-6-6152-9310

Japan - Tokyo
Tel: 81-3-6880-3770
Fax: 81-3-6880-3771

Korea - Daegu
Tel: 82-53-744-4301
Fax: 82-53-744-4302

Korea - Seoul
Tel: 82-2-554-7200
Fax: 82-2-558-5932 or
82-2-558-5934

Malaysia - Kuala Lumpur
Tel: 60-3-6201-9857
Fax: 60-3-6201-9859

Malaysia - Penang
Tel: 60-4-227-8870
Fax: 60-4-227-4068

Philippines - Manila
Tel: 63-2-634-9065
Fax: 63-2-634-9069

Singapore
Tel: 65-6334-8870
Fax: 65-6334-8850

Taiwan - Hsin Chu
Tel: 886-3-5778-366
Fax: 886-3-5770-955

Taiwan - Kaohsiung
Tel: 886-7-213-7830

Taiwan - Taipei
Tel: 886-2-2508-8600
Fax: 886-2-2508-0102

Thailand - Bangkok
Tel: 66-2-694-1351
Fax: 66-2-694-1350

EUROPE

Austria - Wels
Tel: 43-7242-2244-39
Fax: 43-7242-2244-393

Denmark - Copenhagen
Tel: 45-4450-2828
Fax: 45-4485-2829

Finland - Espoo
Tel: 358-9-4520-820

France - Paris
Tel: 33-1-69-53-63-20
Fax: 33-1-69-30-90-79

Germany - Garching
Tel: 49-8931-9700

Germany - Haan
Tel: 49-2129-3766400

Germany - Heilbronn
Tel: 49-7131-67-3636

Germany - Karlsruhe
Tel: 49-721-625370

Germany - Munich
Tel: 49-89-627-144-0
Fax: 49-89-627-144-44

Germany - Rosenheim
Tel: 49-8031-354-560

Israel - Ra'anana
Tel: 972-9-744-7705

Italy - Milan
Tel: 39-0331-742611
Fax: 39-0331-466781

Italy - Padova
Tel: 39-049-7625286

Netherlands - Drunen
Tel: 31-416-690399
Fax: 31-416-690340

Norway - Trondheim
Tel: 47-7289-7561

Poland - Warsaw
Tel: 48-22-3325737

Romania - Bucharest
Tel: 40-21-407-87-50

Spain - Madrid
Tel: 34-91-708-08-90
Fax: 34-91-708-08-91

Sweden - Gothenberg
Tel: 46-31-704-60-40

Sweden - Stockholm
Tel: 46-8-5090-4654

UK - Wokingham
Tel: 44-118-921-5800
Fax: 44-118-921-5820