

3 kW three-channel interleaved PFC evaluation kit based on the STNRGPF01



Data brief

Features

- Input voltage range, $V_{in} = 90 - 265 \text{ V AC}$
- Line frequency range, $f = 47 - 63 \text{ Hz}$
- Maximum output power, $P_{out} = 3 \text{ kW}$ at 230 V
- Output voltage, $V_{out} = 400 \text{ V}$
- Power factor (PF) > 0.98 at 20% load
- Total harmonic distortion, THD $< 5\%$ at 20% load
- Mixed-signal average current mode control, CCM fixed frequency operation
- Switching frequency, $f_{sw} = 111 \text{ KHz}$
- Cycle-by-cycle regulation (analog current control loop)
- Input voltage and load feedforward
- Phase shedding
- Burst-mode operation
- Overvoltage protection
- Thermal protection
- Status indicator LEDs
- Inrush current limiter function
- Smart active cooling function

Description

The EVAL-IPFC01V1 is a 3 kW interleaved PFC board kit based on the STNRGPF01 three-channel interleaved CCM PFC digital controller. The kit is composed of the following three boards:

STEVAL-IPFC01P1 (power board)

STEVAL-IPFC01C1 (control board)

STEVAL-IPFC01A1 (adapter board)

These boards are sold only as part of the EVAL-IPFC01V1 kit, and cannot be ordered separately.

The STNRGPF01 is a digital configurable ASIC developed by STMicroelectronics, capable of driving up to three channels as interleaved PFC for industrial applications in order to meet IEC 61000-3-2 standards for electrical equipment.

The STNRGPF01 device implements mixed-signal (analog/digital) average current mode control in CCM at fixed frequency. The analog section ensures cycle-by-cycle current regulation while the digital section manages the loop and supervises the operations, giving the power stage adequate flexibility. The STNRGPF01 can be customized for specific applications using eDesign Suite, a dedicated software tool. For complete information on the STNRGPF01, please refer to the device datasheet.

Schematic diagrams

Figure 1. STEVAL-IPFC01P1 power board - input section

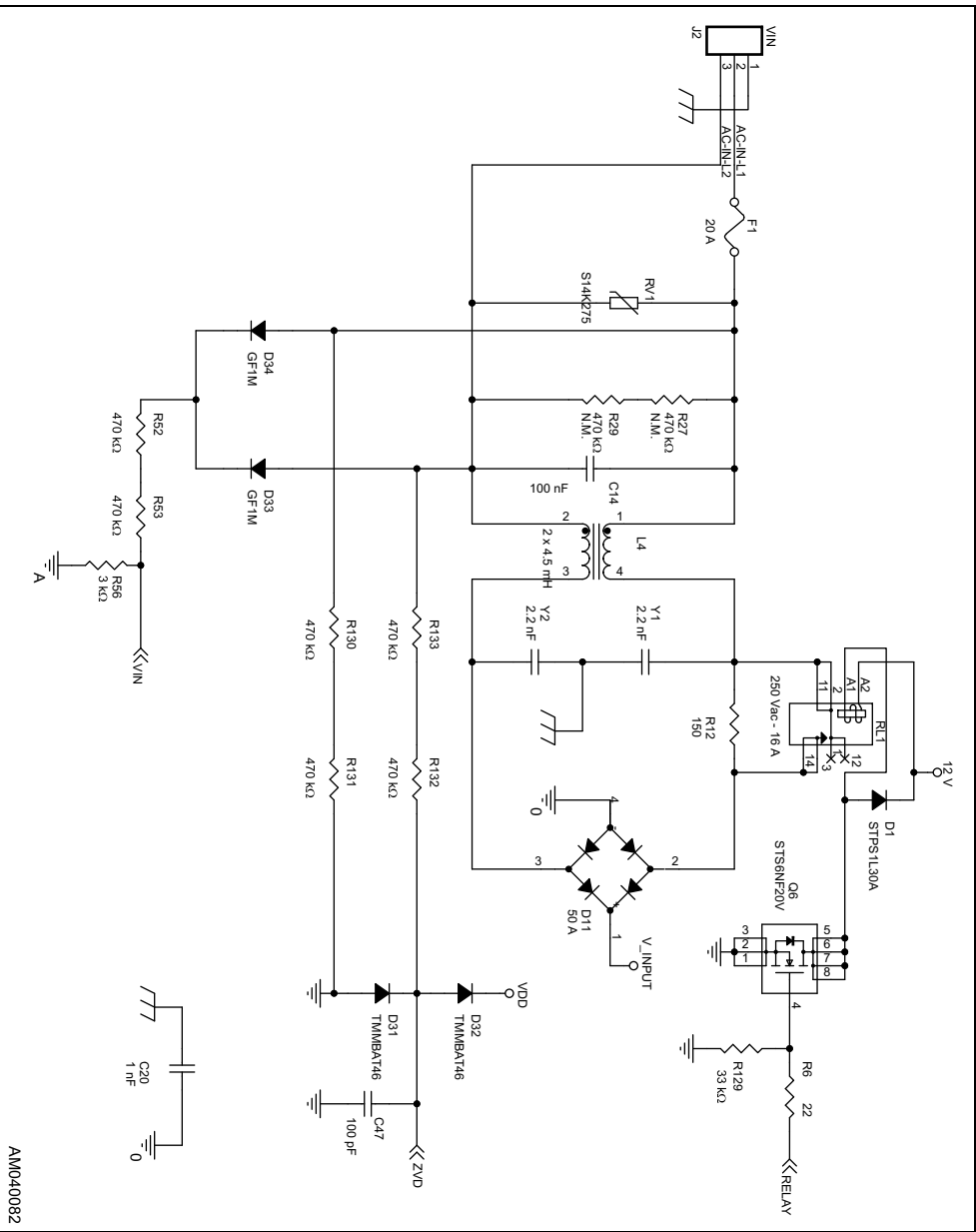
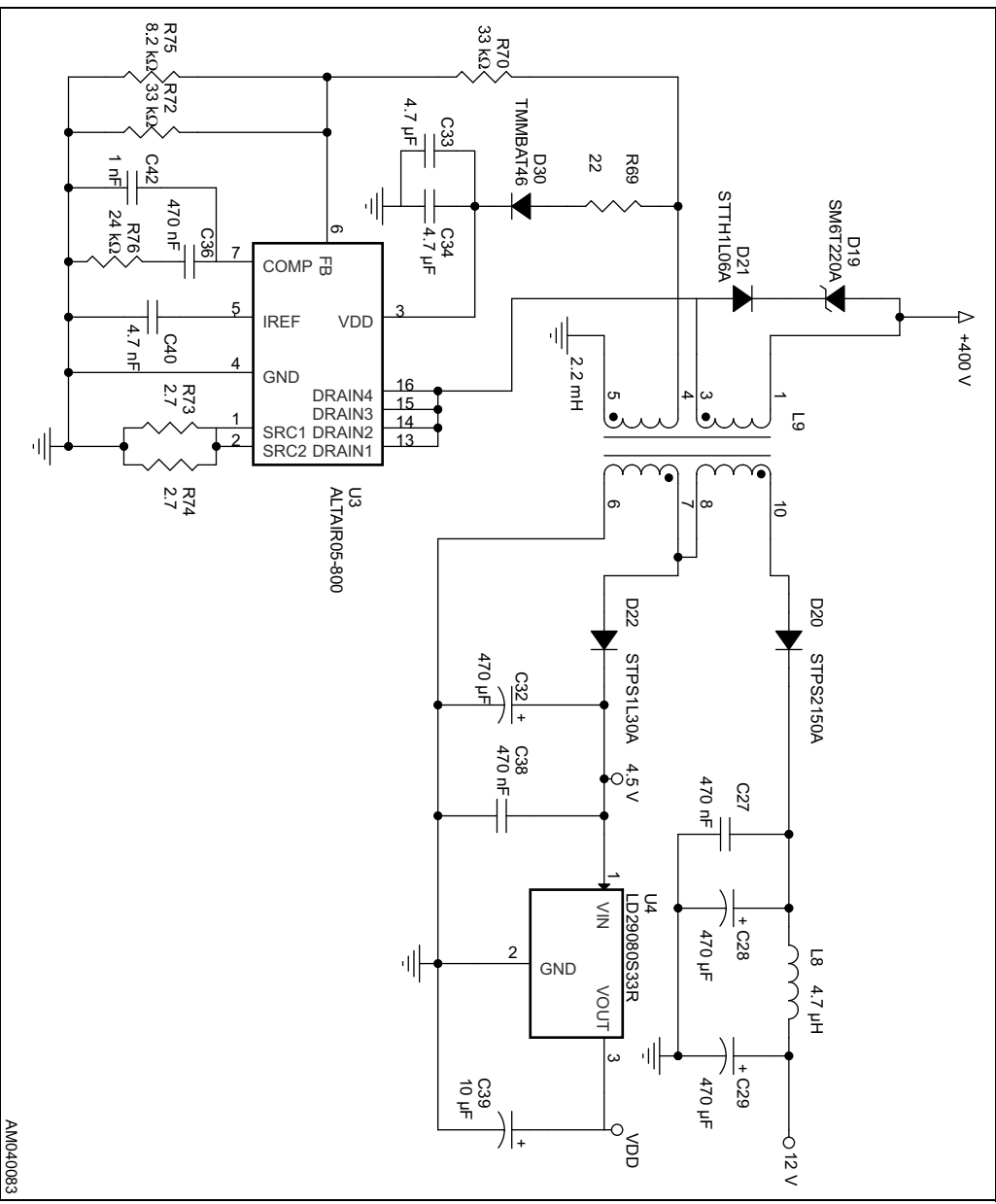
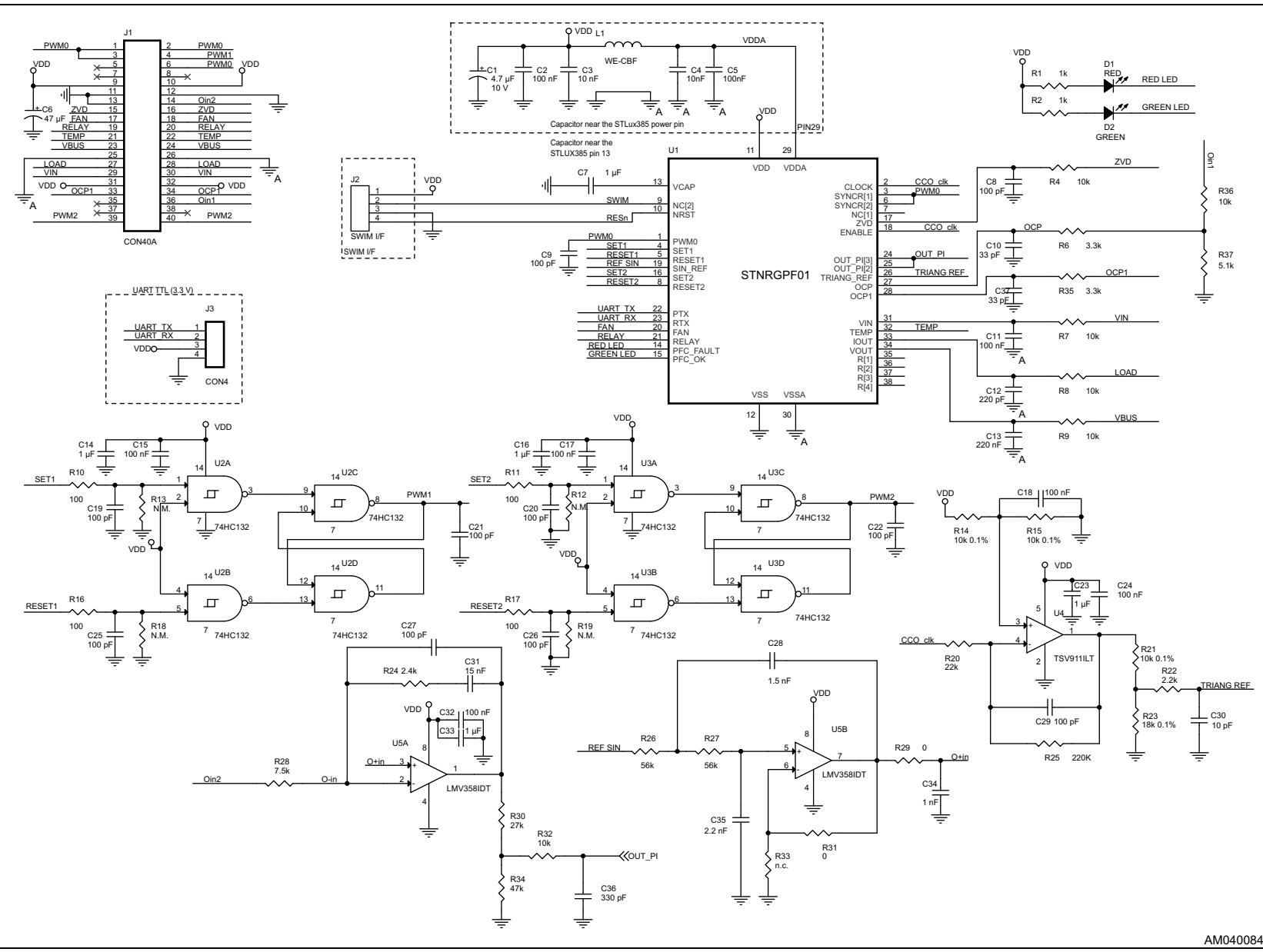

Figure 2. STEVAL-IPFC01P1 power board - auxiliary power supply



AM040083

Figure 3. STEVAL-IPFC01C1 control board



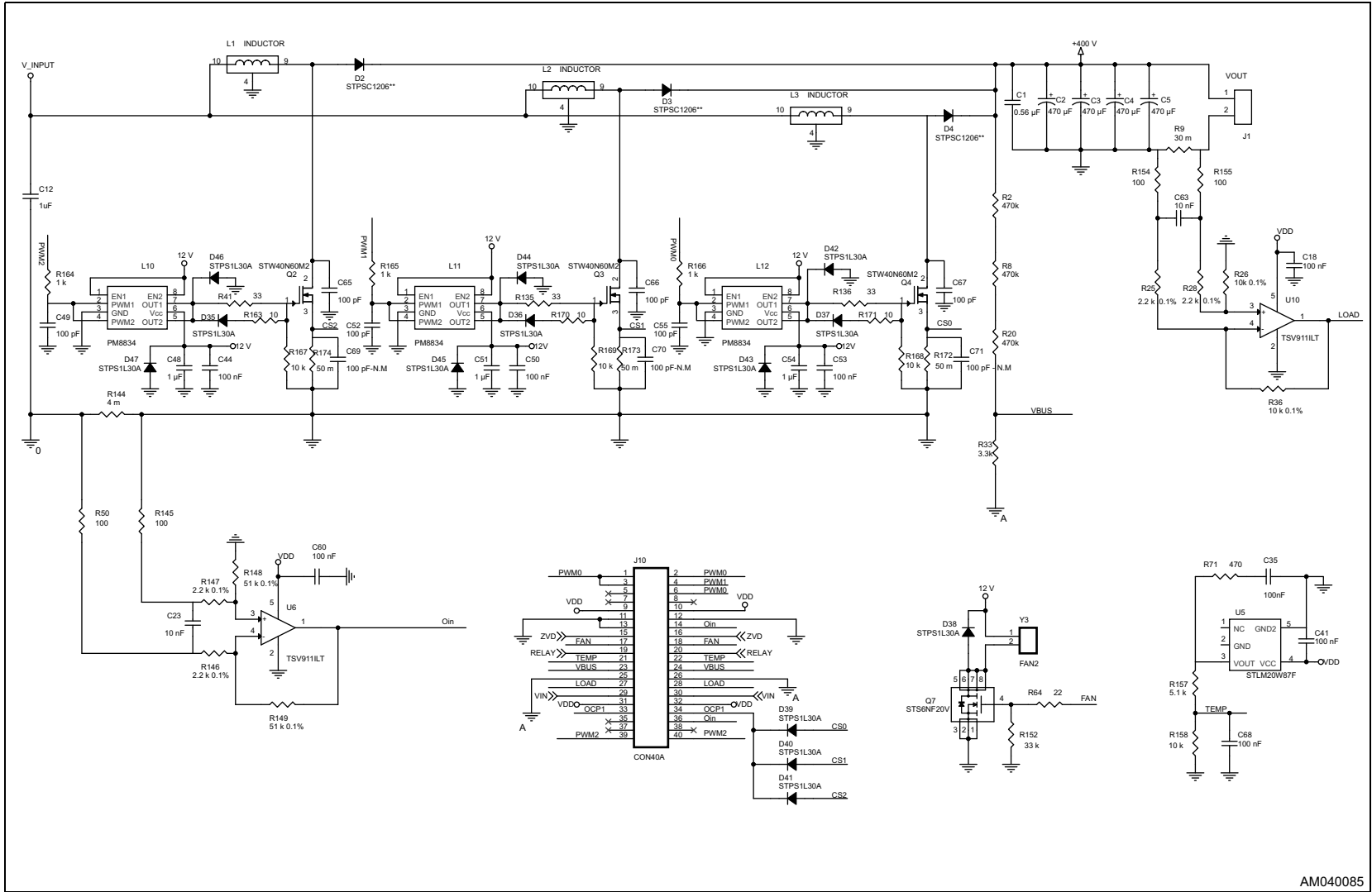

AM040085

Figure 4. STEVAL-IPFC01P1 power board - boost interleaving section

Figure 5. STEVAL-IPFC01A1 adapter board

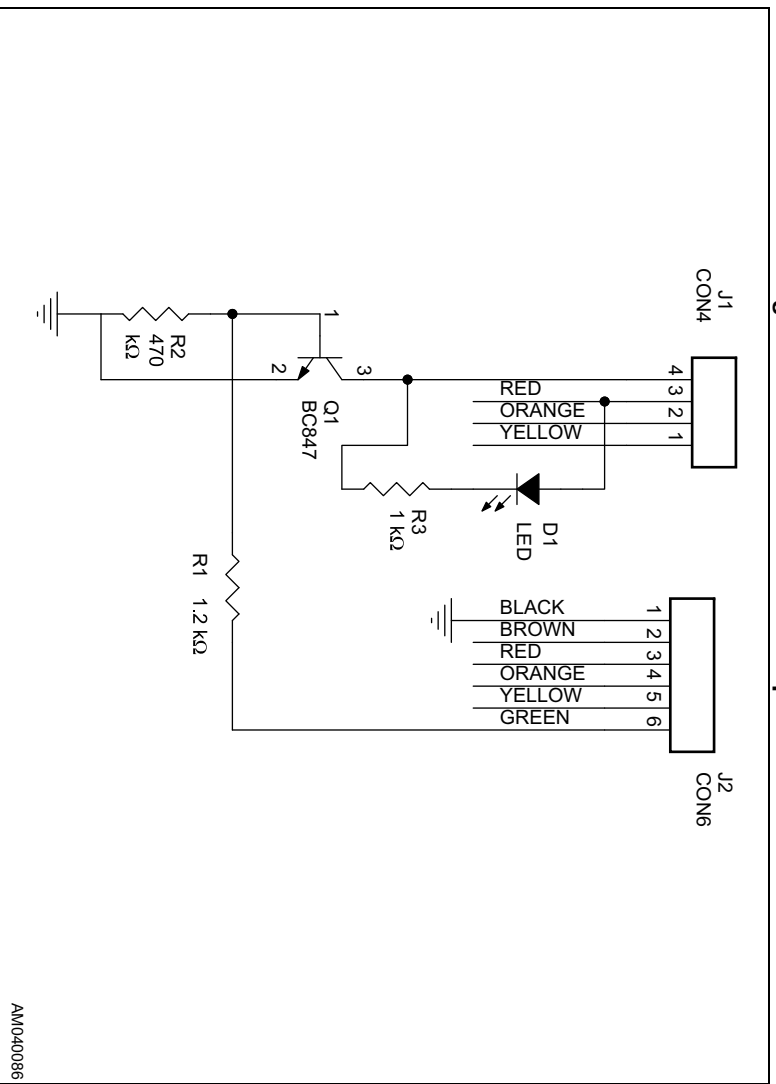

Revision history

Table 1. Document revision history

Date	Revision	Changes
22-Mar-2017	1	Initial release.

IMPORTANT NOTICE – PLEASE READ CAREFULLY

STMicroelectronics NV and its subsidiaries ("ST") reserve the right to make changes, corrections, enhancements, modifications, and improvements to ST products and/or to this document at any time without notice. Purchasers should obtain the latest relevant information on ST products before placing orders. ST products are sold pursuant to ST's terms and conditions of sale in place at the time of order acknowledgement.

Purchasers are solely responsible for the choice, selection, and use of ST products and ST assumes no liability for application assistance or the design of Purchasers' products.

No license, express or implied, to any intellectual property right is granted by ST herein.

Resale of ST products with provisions different from the information set forth herein shall void any warranty granted by ST for such product.

ST and the ST logo are trademarks of ST. All other product or service names are the property of their respective owners.

Information in this document supersedes and replaces information previously supplied in any prior versions of this document.

© 2017 STMicroelectronics – All rights reserved