

Features

- Input voltage: 3.6V to 20V
- Output voltage: 0.8V to V_{CC}
- Duty ratio: 0% to 100% PWM control
- Oscillation frequency: 800KHz typ
- Soft-start Current Limit, Enable function
- Thermal Shutdown function
- Built-in internal SW P-channel MOS
- Low ESR output capacitor (MLCC, multi-layer ceramic capacitor) support
- Efficiency 86%
- SOP-8L: Available in "Green" Molding Compound (No Br, Sb)
- Lead Free Finish / RoHS Compliant (Note 1)

General Description

AP5001 consists of step-down switching regulator with PWM control. These devices include a reference voltage source, oscillation circuit, error amplifier, internal PMOS.

AP5001 provides low-ripple power, high efficiency, and excellent transient characteristics. The PWM control circuit is able to vary the duty ratio linearly from 0 up to 100%. This converter also contains an error amplifier circuit as well as a soft-start circuit that prevents overshoot at startup. An enable function, an over current protect function and a short circuit protect function are built inside, and when OCP or SCP happens, the operation frequency will be reduced from 800KHz to 50KHz. Also, an internal compensation block is built in to minimum external component count.

With the addition of an internal P-channel Power MOS, a coil, capacitors, and a diode connected externally, these ICs can function as step-down switching regulators. They serve as ideal power supply units for portable devices when coupled with the SOP-8L mini-package, providing such outstanding features as low current consumption. Since this converter can accommodate an input voltage up to 20V, it is also suitable for the operation via an AC adapter.

Applications

- PC Motherboard
- LCD Monitor
- Graphic Card
- DVD-Video Player
- Telecom Equipment
- ADSL Modem
- Printer and other Peripheral Equipment
- Microprocessor core supply
- Networking power supply

Ordering Information

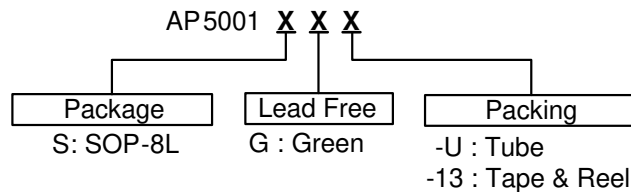

Note: 1. RoHS revision 13.2.2003. Glass and High Temperature Solder Exemptions Applied, see EU Directive Annex Notes 5 and 7.

Device	Package Code	Packaging (Note 2)	Tube		13" Tape and Reel	
			Quantity	Part Number Suffix	Quantity	Part Number Suffix
AP5001S	S	SOP-8L	100	-U	2500/Tape & Reel	-13

Note: 2. Pad layout as shown on Diodes Inc. suggested pad layout document AP02001, which can be found on our website at <http://www.diodes.com/datasheets/ap02001.pdf>.

Pin Assignments

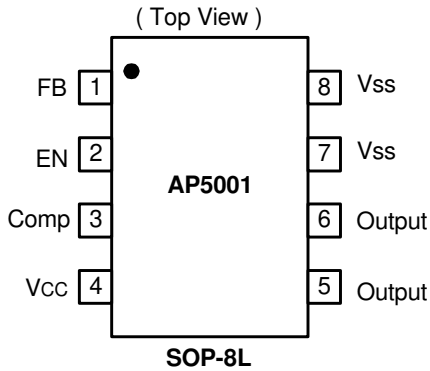

Pin Descriptions

Name	Pin	Description
FB	1	Feedback pin
EN	2	Power-off pin H: Normal operation (Step-down operation) L: Step-down operation stopped (All circuits deactivated)
Comp	3	Compensation pin
V _{CC}	4	IC power supply pin
Output	5, 6	Switch Pin. Connect external inductor/diode here. Minimize trace area at this pin to reduce EMI.
V _{SS}	7, 8	GND Pin

Block Diagram

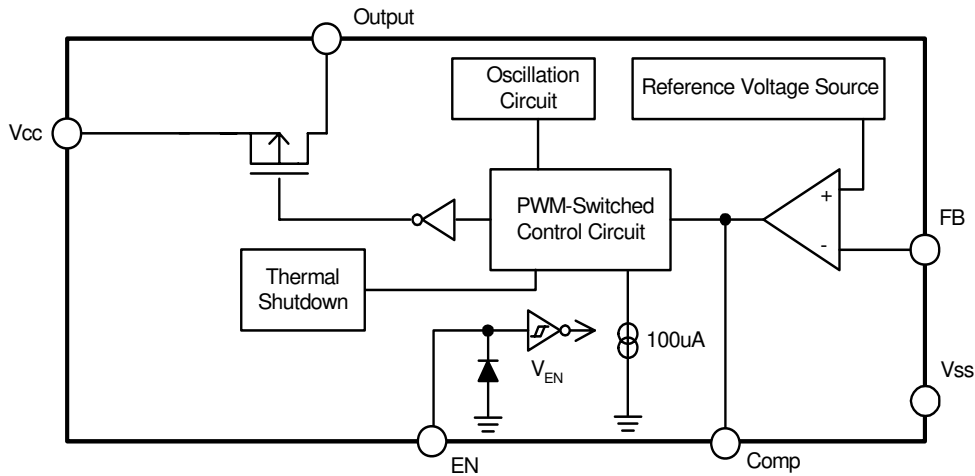

Absolute Maximum Ratings

Symbol	Parameter	Rating	Unit
ESD HBM	Human Body Model ESD Protection	5	KV
ESD MM	Machine Model ESD Protection	200	V
V_{CC}	V_{CC} Pin Voltage	$V_{SS} - 0.3$ to $V_{SS} + 22$	V
V_{FB}	Feedback Pin Voltage	$V_{SS} - 0.3$ to V_{CC}	V
V_{EN}	EN Pin Voltage	$V_{SS} - 0.3$ to V_{IN}	V
V_{OUTPUT}	Switch Pin Voltage	$V_{SS} - 0.3$ to V_{IN}	V
P_D	Power Dissipation	1000	mW
T_J	Operating Junction Temperature Range	-20 to +125	°C
T_{ST}	Storage Temperature Range	-65 to +150	°C

Caution: The absolute maximum ratings are rated values exceeding which the product could suffer physical damage. These values must therefore not be exceeded under any conditions.

Recommended Operating Conditions

Symbol	Parameter	Min	Max	Unit
V_{IN}	Input Voltage	3.6	20	V
I_{OUT}	Output Current	0	1.5	A
T_A	Operating Ambient Temperature	-20	85	°C

Electrical Characteristics ($V_{IN} = 12V$, $T_A = 25^\circ C$, unless otherwise specified)

Symbol	Parameter	Conditions	Min	Typ.	Max	Unit
V_{FB}	Feedback Voltage	$I_{OUT} = 0.1A$	0.784	0.8	0.816	V
I_{FB}	Feedback Bias Current	$I_{OUT} = 0.1A$	-	0.1	0.5	μA
I_{SW}	Switch Current	--	2.5	-	-	A
I_{SSS}	Current Consumption During Power Off	$V_{EN} = 0V$	-	10	-	μA
$\frac{\Delta V_{OUT}}{V_{OUT}}$	Line Regulation	$V_{IN} = 5V \sim 18V$, $I_{OUT} = 0.2A$	-	1	2	%
$\frac{\Delta V_{OUT}}{V_{OUT}}$	Load Regulation	$I_{OUT} = 0.1$ to $1.5A$	-	1	2	%
f_{OSC}	Oscillation Frequency	Measure waveform at SW pin	700	800	900	KHz
f_{OSC1}	Frequency of Current Limit or Short Circuit Protect	Measure waveform at SW pin	40	-	-	KHz
V_{SH}	EN Pin Input Voltage	Evaluate oscillation at SW pin	2.0	-	-	V
V_{SL}		Evaluate oscillation stop at SW pin	-	-	0.8	
I_{SH}	EN Pin Input Leakage	$V_{EN} = 2V$	-10	-	10	μA
I_{SL}	Current	$V_{EN} = 0.8V$	-10	-	10	μA
T_{SS}	Soft-Start Time	--	0.3	2	5	ms
R_{DSON}	Internal MOSFET Rdson	$V_{IN} = 5V$, $V_{FB} = 0V$	-	110	150	m Ω
		$V_{IN} = 12V$, $V_{FB} = 0V$	-	70	100	
	Thermal shutdown			145		$^\circ C$
	Minimum Duty Cycle			6.5		%
θ_{JA}	Thermal Resistance Junction-to-Ambient	SOP-8L (Note 3)		124		$^\circ C/W$
θ_{JC}	Thermal Resistance Junction-to-Case	SOP-8L (Note 3)		25		$^\circ C/W$

Note: 3. Test condition: Device mounted on 2oz copper, minimum recommended pad layout, FR-4 PCB.

Typical Application Circuit

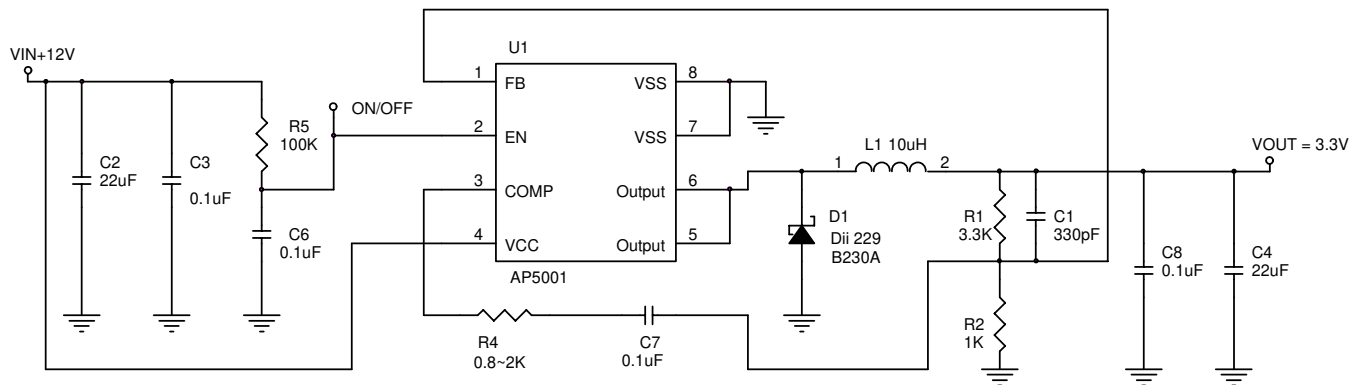

Note: $V_{OUT} = V_{FB} \times \left(1 + \frac{R1}{R2}\right)$

V _{OUT} (V)	R1 (KΩ)	R2 (KΩ)
1	3.3K (1%)	11K (1%)
2.5	2.2K (1%)	1K (1%)
3.3	3.3K (1%)	1K (1%)
5	6.4K (1%)	1.2K (1%)

Typical Performance Characteristics

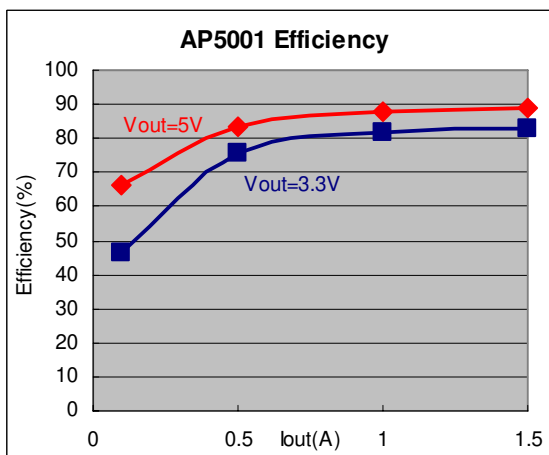
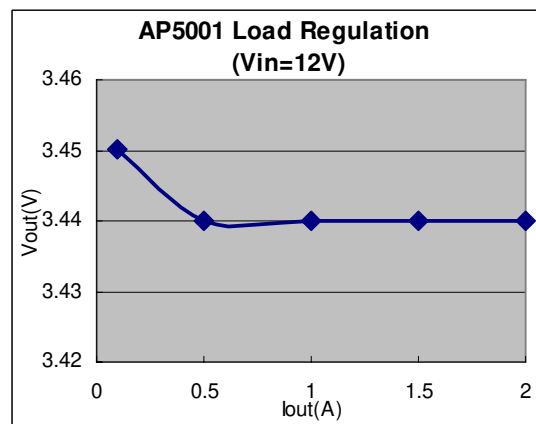
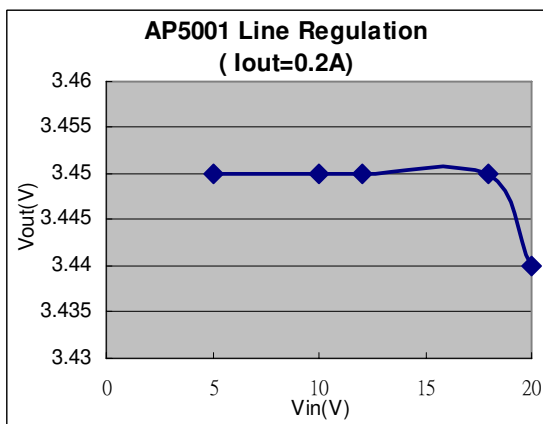
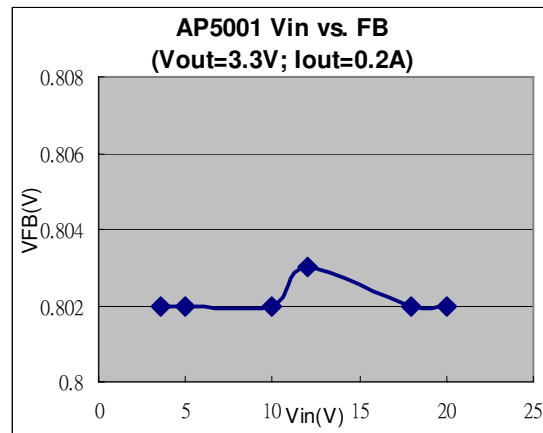
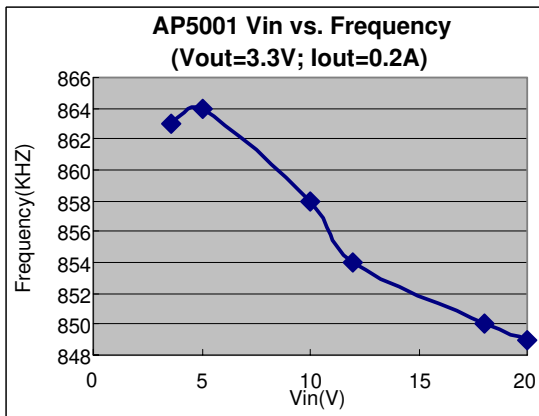

Typical Performance Characteristics (Continued)

AP5001 Vout Ripple
(Vin=12V; Vout=5V; Iout=0.2A)

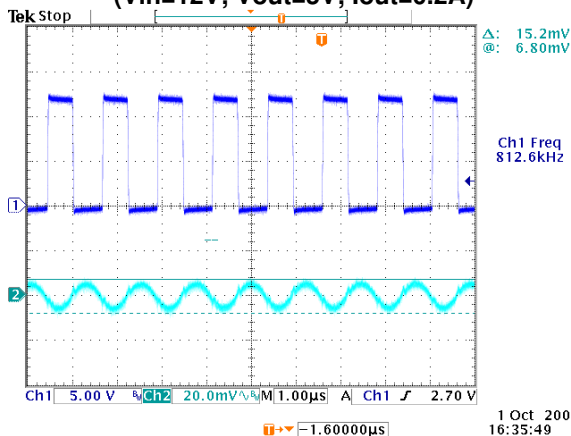

AP5001 Vout Ripple
(Vin=12V; Vout=5V; Iout=1.5A)

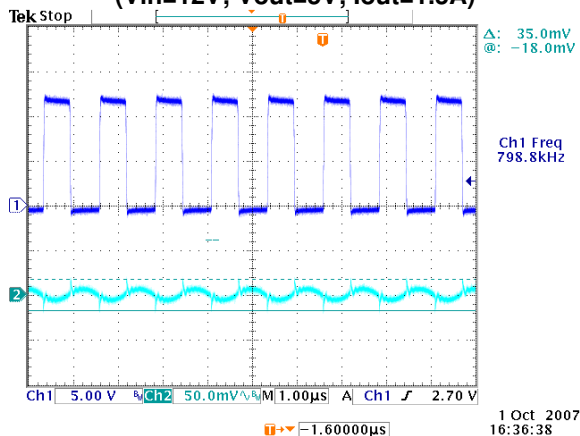

Test Circuit

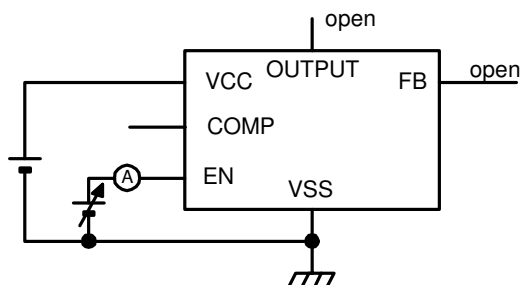

Enable function test

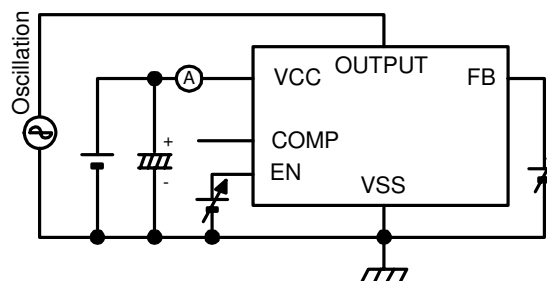

Feedback function test

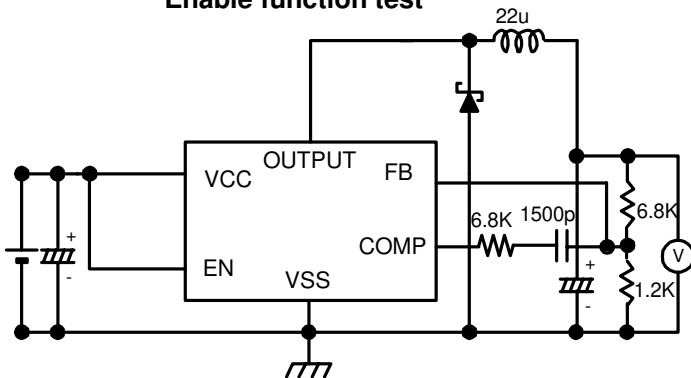

Operation function test

Function Description

PWM Control

The AP5001 consists of DC/DC converters that employ a pulse-width modulation (PWM) system. In converters of the AP5001, the pulse width varies in a range from 0 to 100%, according to the load current. The ripple voltage produced by the switching can easily be removed through a filter because the switching frequency remains constant. Therefore, these converters provide a low-ripple power over broad ranges of input voltage and load current.

Under Voltage Lockout

The under voltage lockout circuit of the AP5001 assures that the high-side MOSFET driver outputs remain in the off state whenever the supply voltage drops below 3.3V. Normal operation resumes once V_{CC} rises above 3.5V.

$R_{DS(ON)}$ Current Limiting

The current limit threshold is setting by the internal circuit.

Marking Information

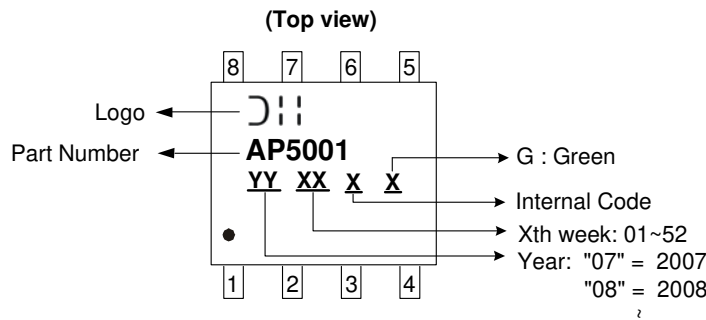

Package Information (unit: mm)

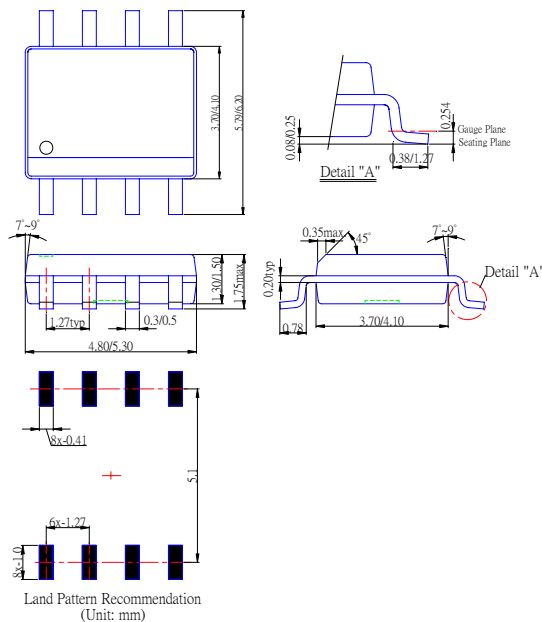

IMPORTANT NOTICE

Diodes Incorporated and its subsidiaries reserve the right to make modifications, enhancements, improvements, corrections or other changes without further notice to any product herein. Diodes Incorporated does not assume any liability arising out of the application or use of any product described herein; neither does it convey any license under its patent rights, nor the rights of others. The user of products in such applications shall assume all risks of such use and will agree to hold Diodes Incorporated and all the companies whose products are represented on our website, harmless against all damages.

LIFE SUPPORT

Diodes Incorporated products are not authorized for use as critical components in life support devices or systems without the expressed written approval of the President of Diodes Incorporated.