

19 V - 65 W quasi resonant flyback adapter board

Data brief

Features

- Universal input mains range: 90 264 Vac - frequency 45 65Hz
- Output voltage: 19 V @ 3.42 A continuous operation
- Mains harmonics: according to EN61000-3-2 Class-D or JEITA-MITI Class-D
- Stand-by mains consumption: <100 mW @ 230 Vac
- Average efficiency: better than 89% without synchronous rectification
- EMI: according to EN55022-Class-B
- Safety: according to EN60950
- Dimensions: 58x121 mm, 25 mm components maximum height
- PCB: single side, 35 μ m, CEM-1, mixed PTH/SMT

Description

The EVL6566B-65W-QR is a demonstration board tailored on specification of a typical hi-end portable computer power supply. The peculiarities of this design are the very high average efficiency of about 90% without synchronous rectification and very low no load consumption of 100mW at 230 Vac. The result is that this converter is compliant to energy star eligibility criteria. The flyback stage implements the new ST dedicated current mode controller L6566B, operating in quasi-resonant mode and detecting the transformer demagnetization by pin ZCD.

The resistor on pin OSC sets the maximum switching frequency at about 165 kHz.

Because the maximum switching frequency is imposed, the converter operates in discontinuous conduction mode during light load operation. The L6566B valley skipping function is capable to

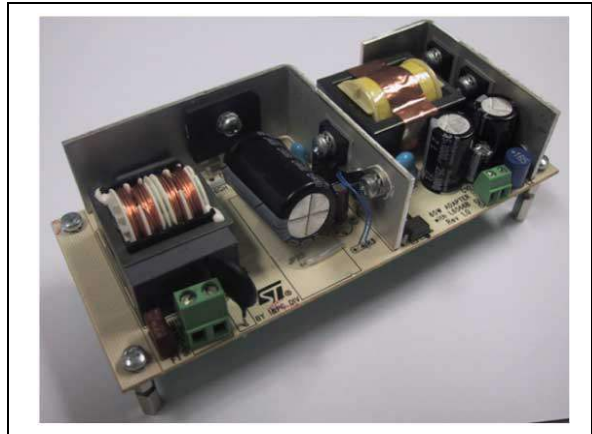

turn-on the MOSFET in valley switching even in DCM, thus reducing switching losses.

The Power MOSFET is a standard 800 V, STF7NM80, housed in TO-220FP package, needing just a small heat sink. The transformer is layer type, using a standard ferrite size EER28L, designed according to the EN60950.

The flyback reflected voltage is ~150 V, providing enough room for the leakage inductance voltage spike with good margin for the reliability of the MOSFET.

The output rectifiers are two, dual centre tap Schottky diode in parallel, STPS20H100CFP, housed in TO-220FP. They have been selected according to the maximum reverse voltage, forward voltage drop and power dissipation. The snubber damps the oscillation produced by the diode capacitance and the leakage inductance.

A small LC filter has been added on the output, filtering the high frequency ripple and spikes.

Thanks to the L6566B valley skipping feature it has been possible to dimension the power transformer parameters optimizing efficiency at different loads achieving an outstanding result even without synchronous rectification.

1 Electrical diagram and efficiency

Figure 1. Electrical diagram

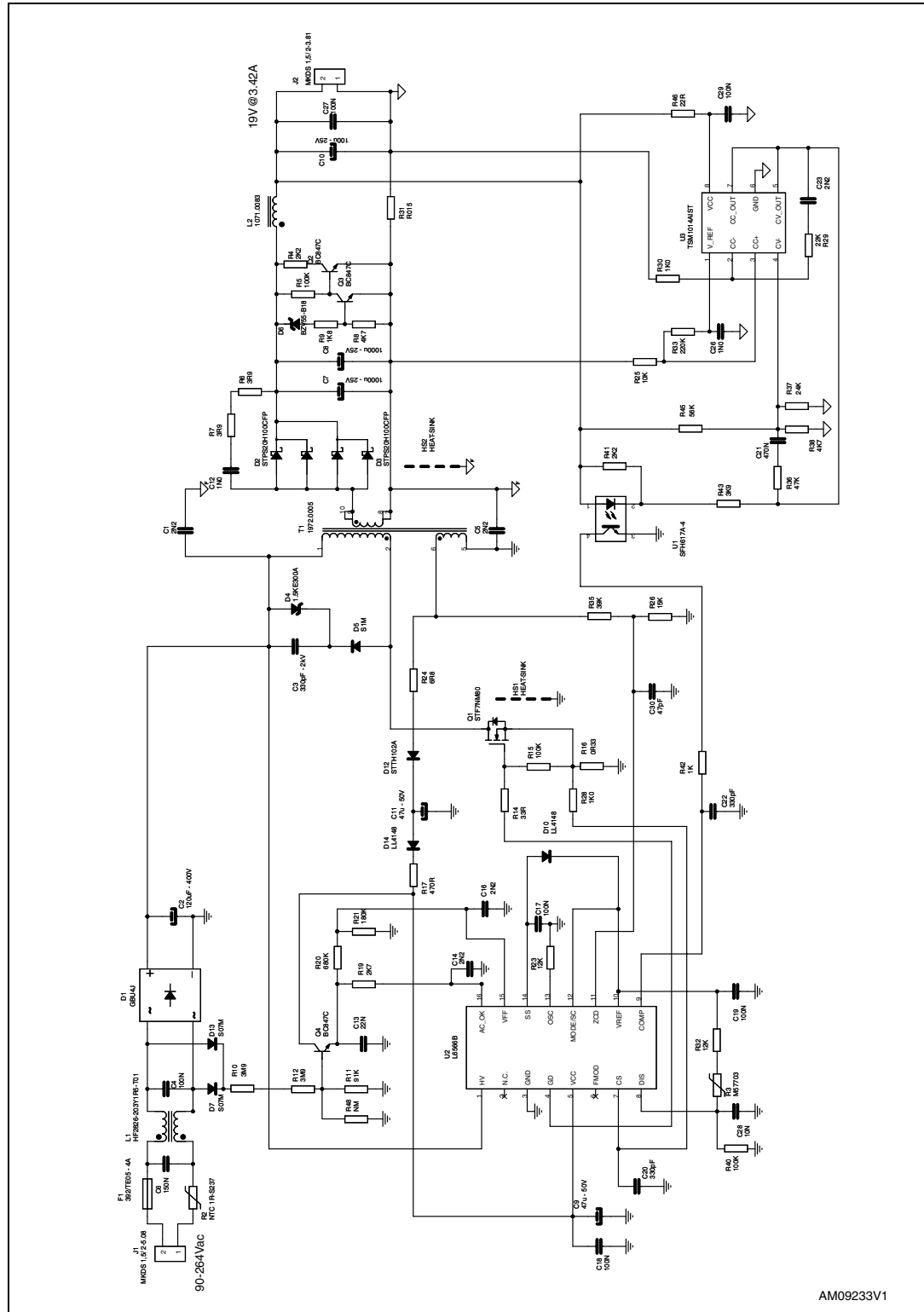

Table 1. Overall efficiency and no load consumption

Test	230 V-50 Hz					115 V-60 Hz				
	Vout [V]	Iout [mA]	Pout [W]	Pin [W]	Eff. [%]	Vout [V]	Iout [A]	Pout [W]	Pin [W]	Eff. [%]
No load	19.00	0.00	0.00	94mW	-	19.00	0.00	0.00	75mW	-
25% load eff.	18.97	0.86	16.37	18.53	88.3	18.97	0.86	16.32	18.03	90.5
50% load eff.	18.97	1.71	32.50	35.77	90.9	18.97	1.72	32.54	35.91	90.6
75% load eff.	18.98	2.57	48.74	53.44	91.2	18.97	2.57	48.82	54.39	89.8
100% load eff.	18.98	3.42	64.89	71.18	91.2	18.98	3.42	64.99	73.30	88.7
Average eff.					90.4					89.9

2 Revision history

Table 2. Document revision history

Date	Revision	Changes
21-Feb-2011	1	Initial release.

Please Read Carefully:

Information in this document is provided solely in connection with ST products. STMicroelectronics NV and its subsidiaries ("ST") reserve the right to make changes, corrections, modifications or improvements, to this document, and the products and services described herein at any time, without notice.

All ST products are sold pursuant to ST's terms and conditions of sale.

Purchasers are solely responsible for the choice, selection and use of the ST products and services described herein, and ST assumes no liability whatsoever relating to the choice, selection or use of the ST products and services described herein.

No license, express or implied, by estoppel or otherwise, to any intellectual property rights is granted under this document. If any part of this document refers to any third party products or services it shall not be deemed a license grant by ST for the use of such third party products or services, or any intellectual property contained therein or considered as a warranty covering the use in any manner whatsoever of such third party products or services or any intellectual property contained therein.

UNLESS OTHERWISE SET FORTH IN ST'S TERMS AND CONDITIONS OF SALE ST DISCLAIMS ANY EXPRESS OR IMPLIED WARRANTY WITH RESPECT TO THE USE AND/OR SALE OF ST PRODUCTS INCLUDING WITHOUT LIMITATION IMPLIED WARRANTIES OF MERCHANTABILITY, FITNESS FOR A PARTICULAR PURPOSE (AND THEIR EQUIVALENTS UNDER THE LAWS OF ANY JURISDICTION), OR INFRINGEMENT OF ANY PATENT, COPYRIGHT OR OTHER INTELLECTUAL PROPERTY RIGHT.

UNLESS EXPRESSLY APPROVED IN WRITING BY AN AUTHORIZED ST REPRESENTATIVE, ST PRODUCTS ARE NOT RECOMMENDED, AUTHORIZED OR WARRANTED FOR USE IN MILITARY, AIR CRAFT, SPACE, LIFE SAVING, OR LIFE SUSTAINING APPLICATIONS, NOR IN PRODUCTS OR SYSTEMS WHERE FAILURE OR MALFUNCTION MAY RESULT IN PERSONAL INJURY, DEATH, OR SEVERE PROPERTY OR ENVIRONMENTAL DAMAGE. ST PRODUCTS WHICH ARE NOT SPECIFIED AS "AUTOMOTIVE GRADE" MAY ONLY BE USED IN AUTOMOTIVE APPLICATIONS AT USER'S OWN RISK.

Resale of ST products with provisions different from the statements and/or technical features set forth in this document shall immediately void any warranty granted by ST for the ST product or service described herein and shall not create or extend in any manner whatsoever, any liability of ST.

ST and the ST logo are trademarks or registered trademarks of ST in various countries.

Information in this document supersedes and replaces all information previously supplied.

The ST logo is a registered trademark of STMicroelectronics. All other names are the property of their respective owners.

© 2011 STMicroelectronics - All rights reserved

STMicroelectronics group of companies

Australia - Belgium - Brazil - Canada - China - Czech Republic - Finland - France - Germany - Hong Kong - India - Israel - Italy - Japan - Malaysia - Malta - Morocco - Philippines - Singapore - Spain - Sweden - Switzerland - United Kingdom - United States of America

www.st.com

