



When precision matters...™

TW3370/TW3372 40dB Wideband GPS/GLONASS Antenna

The TW3370/TW3372 is a high Gain (40dB) GNSS antenna covering the GPS L1, GLONASS L1 and SBAS (WAAS, EGNOS & MSAS) frequency band (1575 to 1606 MHz). It features a patch element with 40% wider bandwidth than previously available in this format. Unlike its competitors, both GPS-L1 and GLONASS signals are included in the 1dB received power bandwidth.

The TW3370/TW3372 has a three stage Low Noise Amplifier with a mid-section SAW. A tight pre-filter is available with the TW3372 to protect against saturation by high level sub-harmonics and L-Band signals making it particularly suitable for timing applications.

The TW3370/TW3372 has a 19mm (3/4 Inch) though hole, permanent mount white-metal base, with an industrial-grade, IP67 compliant conical radome. Two options for pole mounting are available an L-bracket (P/N#23-0040-0) or a pipe mount (P/N#23-0065-0).

Applications

- Timing applications
- Fixed installations
- Cost Sensitive Mission Critical Positioning
- Military & Security



TW3370 / TW3372
Shown with Conical Radome. Low Profile
Radome also available

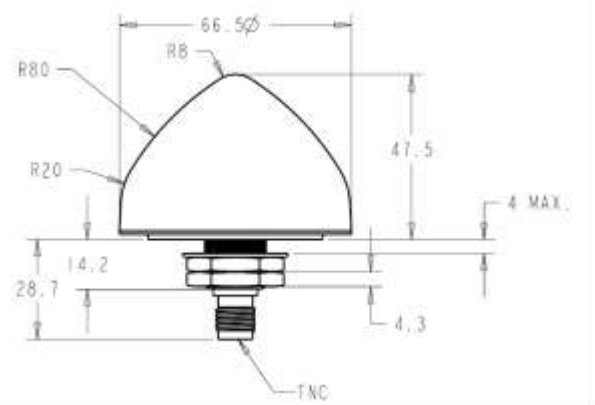

Features

- 40dB LNA Gain
- 1 dB LNA Noise Figure (TW3370)
- Available Pre-filter (TW3372)
- Wide voltage input range: 2.5 to 16 VDC
- IP67 Compliant conical radome
- Low Power: 9mA typ. at 2.3Vcc min.

Benefits

- Bandwidth fully Includes GPS-L1 & GLONASS
- Excellent multipath rejection
- Increased system accuracy
- Excellent signal to noise ratio
- Great out of band signal rejection
- Ideal for harsh environments
- RoHS, REACH, and CE compliant



When precision matters...™

TW3370/TW3372 40dB Wideband GPS/GLONASS Antenna Specification

Antenna

Architecture	Wideband Single Feed Patch
1 dB Bandwidth	31 MHz
10dB Return Loss Bandwidth	45MHz
Antenna Gain (with 100mm ground plane)	4.5 dBic
Axial Ratio	<4dB @ 1590MHz, 8 dB typical at band-edges

Electrical

Architecture	TW3370 TW3372	LNA stage 1 -> SAW filter-> LNA stage 2 SAW Pre-filter ->LNA stage 1 -> SAW filter-> LNA stage 2
Filtered LNA Frequency Bandwidth		1575 to 1606 MHz
Polarization		RHCP
Gain		41 dB min., TW3370 40dB min., TW3372
Gain flatness		+/- 2 dB, 1575 to 1606 MHz
Out-of-Band Rejection	<1500 MHz <1550 MHz >1640 MHz	>32 dB (TW3370) >50dB (TW3372) >25 dB >50dB >35 dB >70dB
VSWR (at LNA output)		<1.5:1 typ 1.8:1 max
Noise Figure		1dB typ. TW3370, 2.5 dB typ. TW3372
Supply Voltage Range (over coaxial cable)		+2.5 to 16 VDC nominal (12VDC recommended maximum)
Supply Current		20 mA max. at 85°C
ESD Circuit Protection		15 KV air discharge

Mechanicals & Environmental

Mechanical Size	66.5 mm dia. x 21 mm H
Operating Temperature Range	-40 to +85 °C
Enclosure	Radome:EXL9330, Base: Zamak White Metal
Weight	150 g
Environmental	IP67, CE, REACH, RED, and RoHS compliant
Shock	Vertical axis: 50 G, other axes: 30 G
Vibration	3 axis, sweep = 15 min, 10 to 200 Hz sweep: 3 G
Salt Fog / Spray	MIL-STD-810F Section 509.4

Ordering Information.

TW3370 – GPS/GLONASS antenna	33-3370-xx-yy-zzzz
TW3372 – GPS GLONASS antenna w/pre-filter	33-3372-xx-yy-zzzz

Where xx = connector type, yy = shape and colour of radome, and zzzz = cable length in mm (where applicable)
Please refer to the Ordering Guide (<http://www.tallysman.com/wp-content/uploads/Current-Ordering-Guide.pdf>) for the current and complete list of available radomes and connectors.



Tel 613 591 3131

36 Steacie Drive, Ottawa ON K2K 2A9 Canada
Fax 613 591 3121 sales@tallysman.com

The information provided herein is intended as a guide only and is subject to change without notice. This document is not to be regarded as a guarantee of performance. Tallysman Wireless Inc. hereby disclaims any or all warranties and liabilities of any kind.
© 2010 Tallysman Wireless Inc. All rights reserved. Rev 2.7