

THIS DOCUMENT IS THE PROPERTY OF KEYSTONE ELECTRONICS CORP. AND SHALL NOT BE REPRODUCED, DISTRIBUTED OR USED AS A BASIS FOR MANUFACTURE WITHOUT PRIOR WRITTEN PERMISSION FROM KEYSTONE ELECTRONICS CORP.

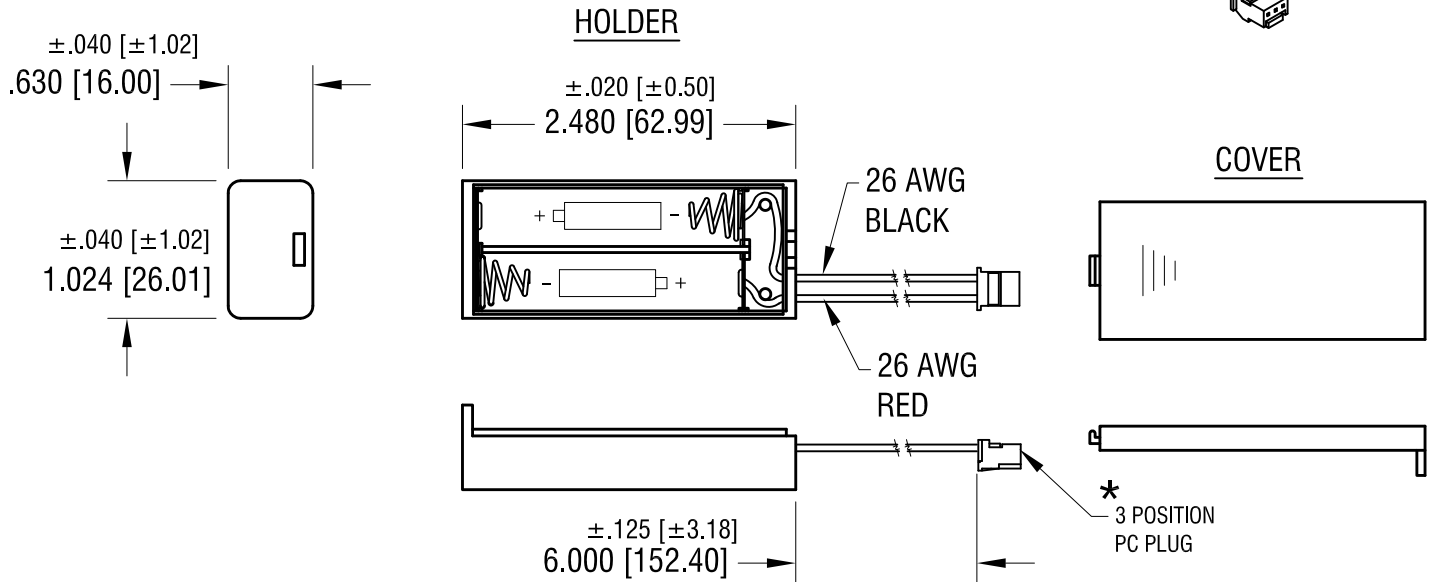
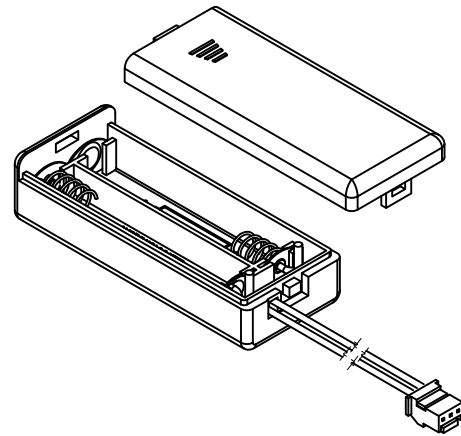

**NOTE:**

1. HOLDER: MAT'L: A.B.S., BLACK
2. WIRE: 26 AWG, 1007 UL/CSA APPROVED
3. SPRING: MAT'L: MUSIC WIRE, .020 [0.50] DIA.  
FINISH: NICKEL PLATE
4. CONNECTOR: MAT'L - PA 66, UL94V-0  
COLOR- NATURAL
5. POSITIVE (RED) CONNECTED TO PIN 1  
NEGATIVE (BLACK) CONNECTED TO PIN 3

\*USE : P/N'S 974,975, 976 OR 977 FOR P.C. CONNECTOR

<b>KEYSTONE ELECTRONICS CORP.</b>			
www.keyelco.com • NEW HYDE PARK, NY 11040 • Tel (516) 328-7500			
PART NAME			
BATTERY HOLDER AND COVER (2) 'AAA'			
MATERIAL			
AS NOTED			
FINISH		DRN BY	DATE
AS NOTED		NT	7.20.16
		APP'D	SCALE
		LN	.7X
TOLERANCES	INCH	[MM]	CODE
DECIMAL	± .015	[± 0.38]	C
ANGULAR	± 1°		DWG NO.
UNLESS OTHERWISE SPECIFIED			<b>2489CN</b>

DATE	DESCRIPTION	REV.