

LP5890 48x16 Common Cathode Matrix LED Display Driver Evaluation Module



Abstract

This user's guide describes the LP5890 evaluation module used as a reference for engineering demonstration and evaluation. Included in this user's guide are setup instructions, a schematic diagram, printed board (PCB) layout, and a bill of materials (BOM).

Table of Contents

Abstract	1
1 Introduction	2
1.1 Features.....	2
1.2 Applications.....	2
2 Function Descriptions	3
3 Test Setup	6
3.1 System/Tool Requirements.....	6
3.2 Software Setup.....	6
3.3 Hardware Setup for Single Device.....	7
3.4 Hardware Setup for Dual Cascaded Devices.....	8
4 Additional Resources	10
5 Schematic	11
6 Layout	14
7 Bill of Materials	15

List of Figures

Figure 2-1. Driver IC Side of the LP5890EVM Board.....	3
Figure 2-2. LED Side of the LP5890EVM Board.....	4
Figure 3-1. Installation Process of Code Composer Studio.....	7
Figure 3-2. Single LP5890EVM Connected with the MSP430F5529 LaunchPad.....	8
Figure 3-3. Dual Cascaded LP5890EVM Connected with the MSP430F5529 LaunchPad.....	9
Figure 5-1. LP5890EVM Schematic (1 of 4).....	11
Figure 5-2. LP5890EVM Schematic (2 of 4).....	11
Figure 5-3. LP5890EVM Schematic (3 of 4).....	12
Figure 5-4. LP5890EVM Schematic (4 of 4).....	13
Figure 6-1. LP5890EVM Top Layer.....	14
Figure 6-2. LP5890EVM Signal Layer 1.....	14
Figure 6-3. LP5890EVM Signal Layer 2.....	14
Figure 6-4. LP5890EVM Bottom Layer.....	14

List of Tables

Table 2-1. Connectors.....	4
Table 2-2. Jumpers.....	5
Table 2-3. Switches.....	5
Table 3-1. LP5890EVM Parameters.....	6
Table 7-1. Bill of Materials.....	15

Trademarks

LaunchPad™ is a trademark of Texas Instruments.
All trademarks are the property of their respective owners.

1 Introduction

1.1 Features

The LP5890 is a highly integrated, common cathode matrix LED display driver with 48 constant current sources and 16 scanning FETs. One LP5890 is capable of driving 16×16 RGB LED pixels, while stacking two LP5890 can drive 32×32 RGB LED pixels, which simplifies component placement and control. With the common cathode structure, the device supports separated power supplies for the red, green, and blue LEDs to achieve low power consumption. Furthermore, the operation power of the LP5890 is significantly reduced by ultra-low operation voltage range (V_{cc} down to 2.5 V) and ultra-low operation current (I_{cc} down to 3.9 mA).

The LP5890 device supports per-channel current from 0.2 mA to 20 mA, with typical 1% channel-to-channel current deviation and typical 1% device-to-device current deviation. The DC current value of all 48 channels is set by an external IREF resistor and can be adjusted by the 8-step global brightness control (BC) and the 256-step per-color group brightness control (CC_R/CC_G/CC_B).

The LP5890 implements a high speed, rising-edge transmission interface to support up to 32 cascaded devices. The device supports up to 50 MHz SCLK (external) and high refresh rate with maximum 160 MHz GCLK (internal). Meanwhile, the device integrates enhanced circuits and intelligent algorithms to solve the various display challenges in Narrow Pixel Pitch(NPP) LED display applications and mini or micro-LED products: dim at the first scan line, upper and downside ghosting, non-uniformity in low grayscale, coupling, caterpillar caused by open or short LEDs, which make the LP5890 a perfect choice in such applications.

The LP5890 also implements LED open, weak short, short detection and removal during operations and can also report the accurate fault position information out to the accompanying digital processor.

1.2 Applications

The LP5890EVM can be used as a basic function evaluation module for the following applications:

- LED digital signage
- Keyboard and gaming accessories
- Major and smart home appliances
- Smart speaker, wired and wireless speaker
- Audio mixer, DJ equipment, and broadcast
- Access equipment, switches, and servers

2 Function Descriptions

This section describes the connectors, jumpers and switches on LP5890EVM board.

Figure 2-1 shows the image of the driver IC side of the LP5890EVM board.

Figure 2-2 shows the image of the LED side of the LP5890EVM board.

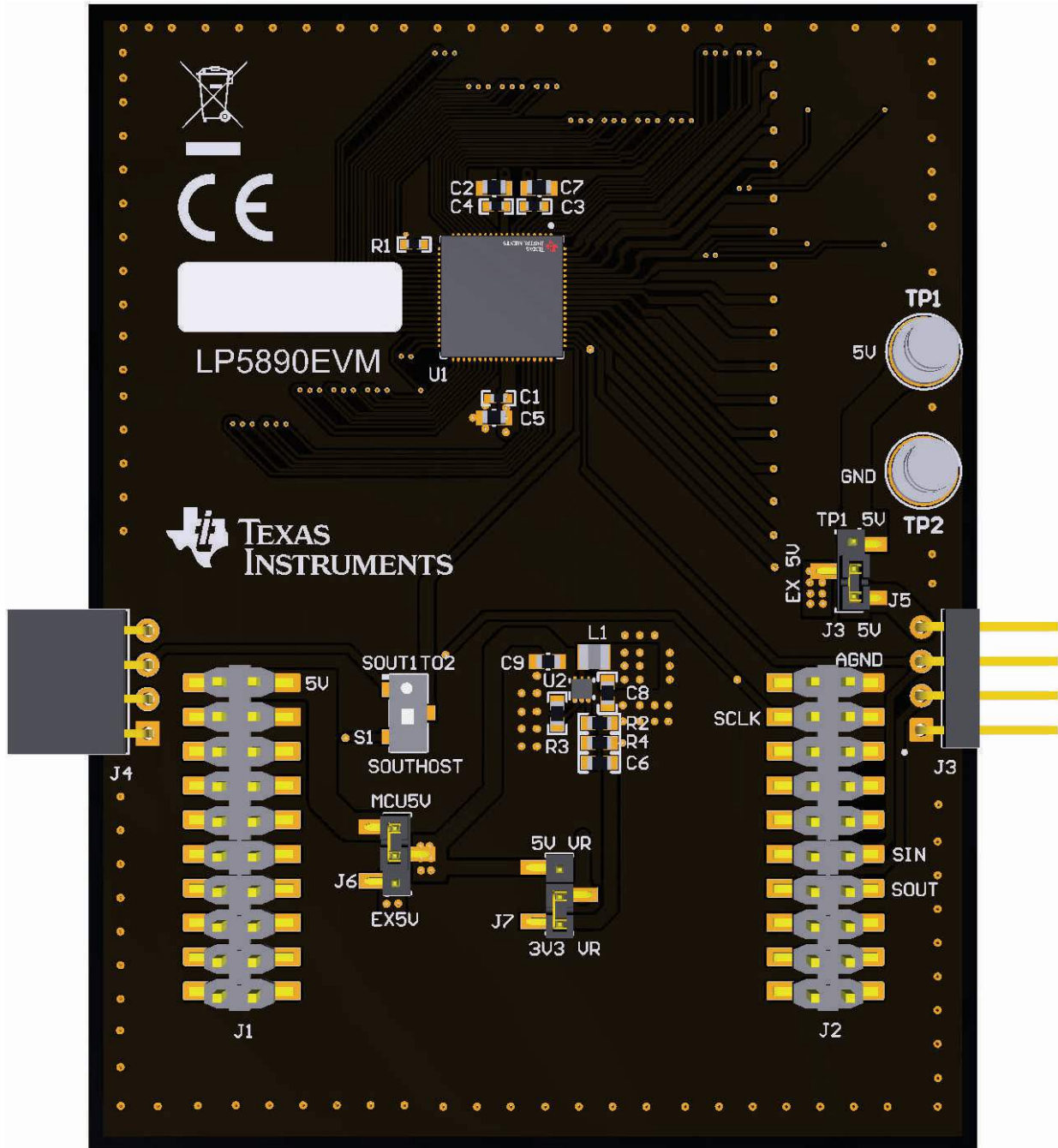

Figure 2-1. Driver IC Side of the LP5890EVM Board

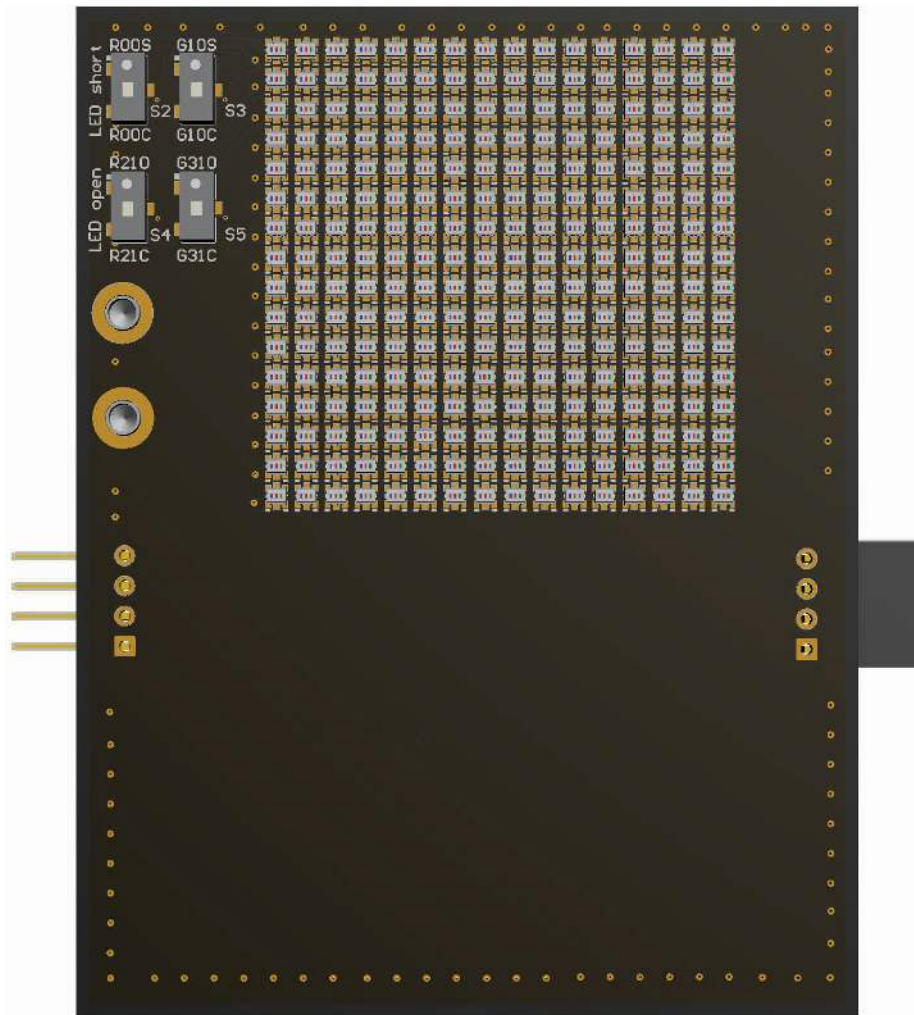

Figure 2-2. LED Side of the LP5890EVM Board

The LP5890EVM works with a host controller, the MSP430F5529 LaunchPad™. The LP5890EVM is designed with connectors, jumpers and switches to support device-to-device connection, device-to-host connection and flexible power supply scheme. In addition, there are four switches on the LED side of the LP5890EVM board that enables the evaluation of LED open and short detection and removal functions of the LP5890.

[Table 2-1](#) lists the connectors of LP5890EVM board and their descriptions.

[Table 2-2](#) lists the jumpers of LP5890EVM board and their descriptions.

[Table 2-3](#) lists the switches of LP5890EVM board and their descriptions.

Table 2-1. Connectors

Name	Description
J1, J2	Boosterpack connectors for connecting with the MSP430F5529 LaunchPad.
J3	Input board-to-board connectors between LP5890EVM boards, including +5V, SIN (serial data input), SCLK (serial clock) and GND.
J4	Output board-to-board connectors between LP5890EVM boards, including +5V, SOUT (serial data output), SCLK (serial clock) and GND.
TP1 (+5 V)	External power supply that can be selected for VLEDG/VLEDB and DC/DC.
TP2 (GND)	Supply ground.

Table 2-2. Jumpers

Name	Description
J3	<p>J3 is used to select external +5V power supply.</p> <ul style="list-style-type: none"> Put the jumper on "TP1 5V" and "EX 5V" to select the external power supply from TP1. Put the jumper on "J3 5V" and "EX 5V" to select the external power supply from J3.
J6	<p>J3 is used to select the +5V power supply that supplies VLEDG/VLEDB and DC/DC.</p> <ul style="list-style-type: none"> Put the jumper on "MCU5V" and the middle to select the +5V power supply from the host controller. Put the jumper on "EX5V" and the middle to select the external +5V power supply, which is previously selected by J3.
J7	<p>J7 is used to select the power supply that supplies VLEDR.</p> <ul style="list-style-type: none"> Put the jumper on "5V VR" and the middle to select +5V power supply for VLEDR. The +5V power supply is previously selected by J6. Put the jumper on "3V3 VR" and the middle to select +3.3V power supply for VLEDR. The +3.3V power supply is generated by DC/DC.

Table 2-3. Switches

Name	Description
S1	<ul style="list-style-type: none"> If the switch is set towards "SOUTHST", the serial data output from LP5890 chip is sent back to the host controller. If the switch is set towards "SOUT1TO2", the serial data output from the first LP5890 chip is sent to J4 port, which is further sent to the second chip if several LP5890EVM are cascaded.
S2	<ul style="list-style-type: none"> If the switch is set towards "R00C", the red LED in row 0, column 0 is connected in normal state. If the switch is set towards "R00S", the red LED in row 0, column 0 is shorted (The anode and the cathode of the LED are shorted).
S3	<ul style="list-style-type: none"> If the switch is set towards "G10C", the green LED in row 1, column 0 is connected in normal state. If the switch is set towards "G10S", the green LED in row 1, column 0 is shorted (The anode and the cathode of the LED are shorted).
S4	<ul style="list-style-type: none"> If the switch is set towards "R21C", the red LED in row 2, column 1 is connected in normal state. If the switch is set towards "R21O", the red LED in row 2, column 1 is opened (The anode of the LED is disconnected from the current source channel).
S5	<ul style="list-style-type: none"> If the switch is set towards "G31C", the green LED in row 3, column 1 is connected in normal state. If the switch is set towards "G31O", the green LED in row 3, column 1 is opened (The anode of the LED is disconnected from the current source channel).

3 Test Setup

Table 3-1 shows the typical parameters for LP5890EVM.

Table 3-1. LP5890EVM Parameters

Parameter	Value
VCC Device supply voltage	2.5–5.5 V
VLEDR/G/B supply voltage	2.5–5.5 V
ICH Constant output source current	0.2–20 mA

The LP5890EVM can work with the MSP430F5529 LaunchPad.

The LP5890EVM is designed to work in two different modes:

- Single device
- Multiple cascaded devices in independent mode

For simplicity, the test setup for single device and dual devices are illustrated.

3.1 System/Tool Requirements

To perform the test, these hardware tools are required:

- LP5890EVM × 1 (or more)
- [MSP430F5529 USB LaunchPad development kit](#) × 1
- Computer × 1
- (optional) DC power supply × 1
- (optional) DC power supply cables
- (optional) 1-pin female-to-female jumper wire × 1

To perform the test, these software tools are required:

- [Code Composer Studio™ integrated development environment \(IDE\)](#) (Version ≥ 11)
- [LP5890EVM-SW-F5529](#) (Sample code guide can be found at [LP589x and TLC698x Sample Code Quick Start Guide](#))
- (optional) [LP5890 Registers Map Generation Tool](#)

3.2 Software Setup

In order to set up the software for the MSP430F5529 LaunchPad, please follow these steps (demonstrated in a computer with Windows 10 OS):

1. Download and install Code Composer Studio
 - a. Download [Code Composer Studio integrated development environment \(IDE\)](#) (Version ≥ 11).
 - b. Follow the [installation instructions](#) to install Code Composer Studio. During the installation process, if you choose the "Setup type" to be "Custom Installation", make sure that you select "MSP430 ultra-low power MCUs" in "Select Components", as is marked with red box in [Figure 3-1](#).

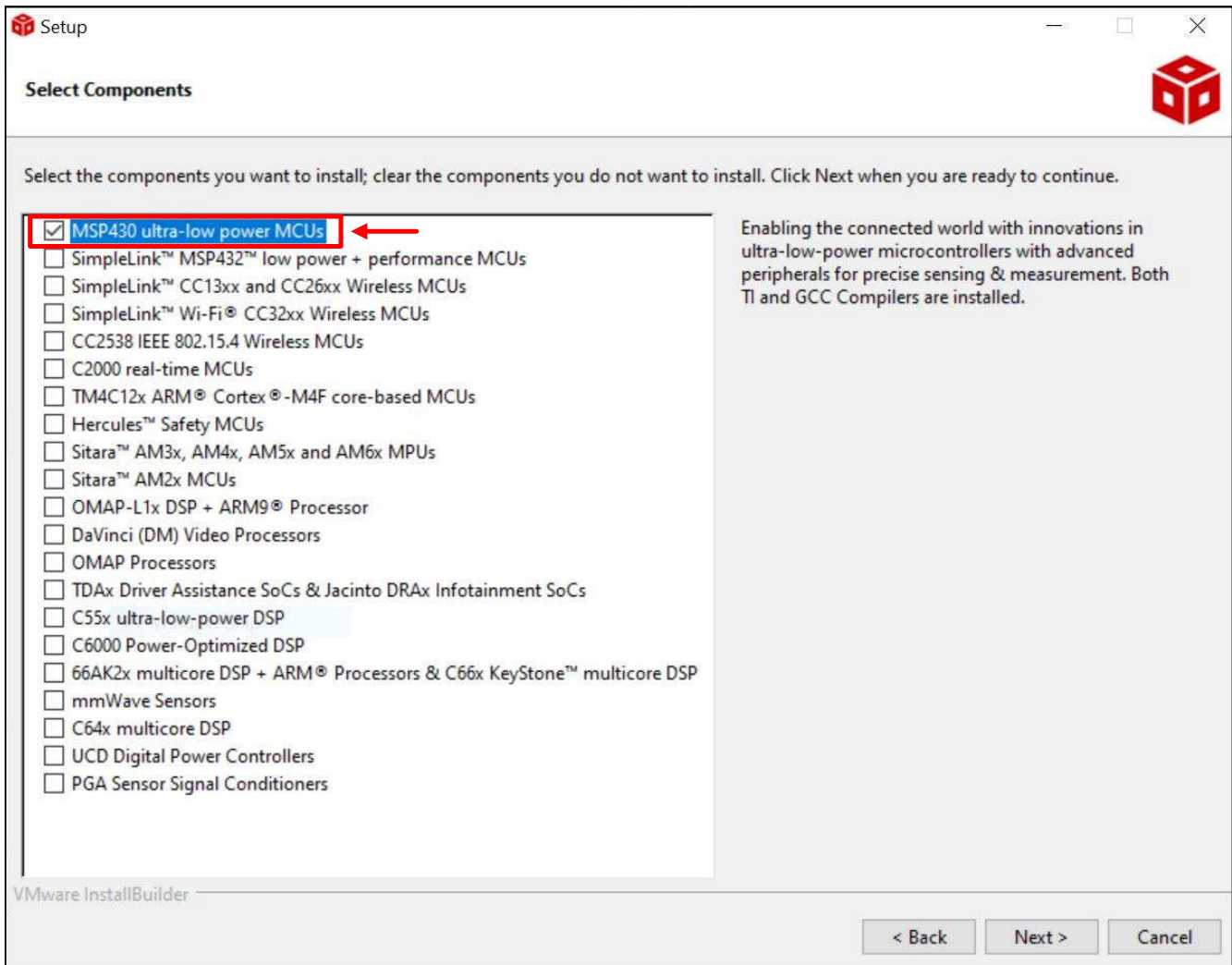

Figure 3-1. Installation Process of Code Composer Studio

2. Download and import LP5890 sample code
 - a. Download link: [LP5890EVM-SW-F5529](#)
 - b. Importing the CCS (Code Composer Studio) project according to the process provided in the link: [Importing a CCS Project](#).
3. Load the program according to the process provided in the link: [Building and Running Your Project](#).
4. (optional) Download [LP5890 Registers Map Generation Tool](#), which is a handy tool if you want to further configure the registers of LP5890.
5. (optional) Check [LP589x and TLC698x Sample Code Quick Start Guide](#), where you can find guidance on software setup for LED fault diagnostics, cascading devices, animation control, etc.

3.3 Hardware Setup for Single Device

The LP5890EVM can be powered either by the MSP430F5529 LaunchPad with the USB power (when the current consumption is low) or an external power supply (the LP5890EVM and the MSP430F5529 LaunchPad are powered separately). Single LP5890EVM can be quickly set up and tested by following these steps:

1. USB power supply from the MSP430F5529 LaunchPad
 - a. Download the code to the MSP430F5529 LaunchPad with TI Code Composer Studio software.
 - b. Put the J6 jumper on "MCU5V" and the middle, and set the switch S1 towards "SOUTHST" , which are marked with red boxes in [Figure 3-2](#).
 - c. Connect BoosterPack connectors (J1, J2) on the LP5890EVM with the MSP430F5529 LaunchPad, the connection method is shown in [Figure 3-2](#).
 - d. Power the MSP430F5529 LaunchPad through the USB cable.

2. External power supply
 - a. Download the code to the MSP430F5529 LaunchPad with TI Code Composer Studio software.
 - b. Put the J5 jumper on "TP1 5V" and "EX 5V". Then put the J6 jumper on "EX5V" and the middle. Set the switch S1 towards "SOUTHST".
 - c. Connect BoosterPack connectors (J1, J2) on the LP5890EVM with the MSP430F5529 LaunchPad, the connection method is shown in [Figure 3-2](#).
 - d. Power the MSP430F5529 LaunchPad through the USB cable.
 - e. Connect TP1 and TP2 to 5V/GND power source.
 - f. Power on 5V/GND power supply.

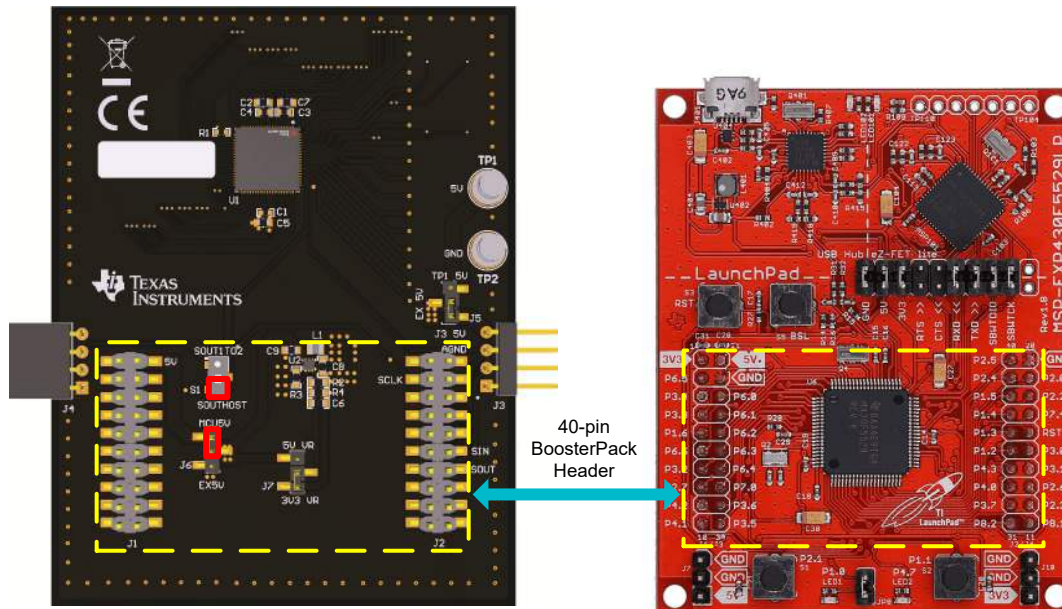

Figure 3-2. Single LP5890EVM Connected with the MSP430F5529 LaunchPad

3.4 Hardware Setup for Dual Cascaded Devices

The LP5890EVM can be cascaded in a daisy chain. In such case, each LP5890 works in the independent mode (compared to the stackable mode). The host MSP430F5529 LaunchPad sends the serial data to the first LP5890 through the 40-pin BoosterPack Header. Then the first LP5890 transmits the serial data through board-to-board connector (J3 and J4) to the second LP5890. The second LP5890 can transmit the serial data to the host with an additional 1-pin cable. The serial data are transmitted through the daisy chain, while the clock signal is shared between multiple devices.

When multiple LP5890EVM are cascaded in a daisy chain, using an external power supply is recommended due to the large current consumption. Also, an additional digital buffer for SCLK may be needed if the drive strength of the controller is not enough.

Dual cascaded LP5890EVM in independent mode can be quickly set up and tested by following these steps:

1. Download the code to the MSP430F5529 LaunchPad with TI Code Composer Studio software.
2. For the first LP5890EVM, put the J5 jumper on "TP1 5V" and "EX 5V". Then put the J6 jumper on "EX5V" and the middle. Set the switch S1 towards "SOUT1TO2". These setups are marked with red boxes on the "First Device" in [Figure 3-3](#).
3. For the second LP5890EVM, put the J5 jumper on "J3 5V" and "EX 5V". Then put the J6 jumper on "EX5V" and the middle. Set the switch S1 towards "SOUTHST". These setups are marked with red boxes on the "Second Device" in [Figure 3-3](#).
4. Connect BoosterPack connectors (J1, J2) on the first LP5890EVM with the MSP430F5529 LaunchPad, the connection method is shown in [Figure 3-3](#).
5. Connect the J4 connector of the first LP5890EVM to the J3 connector of the second LP5890EVM. The direction is shown in [Figure 3-3](#).

6. (Optional) Connect the SOUT pin of connector J2 on the second LP5890EVM to the P3.1 pin of connector J4 on the MSP430F5529 LaunchPad through an additional 1-pin cable that is marked as the bottom blue line in [Figure 3-3](#). This step enables LP5890EVM to report LOD (LED Open Detection), and LSD (LED Short Detection) out to the host MSP430F5529 LaunchPad.
7. Power the MSP430F5529 LaunchPad through the USB cable.
8. Connect TP1 and TP2 on the first LP5890EVM to 5V/GND power source.
9. Power on 5V/GND power supply.

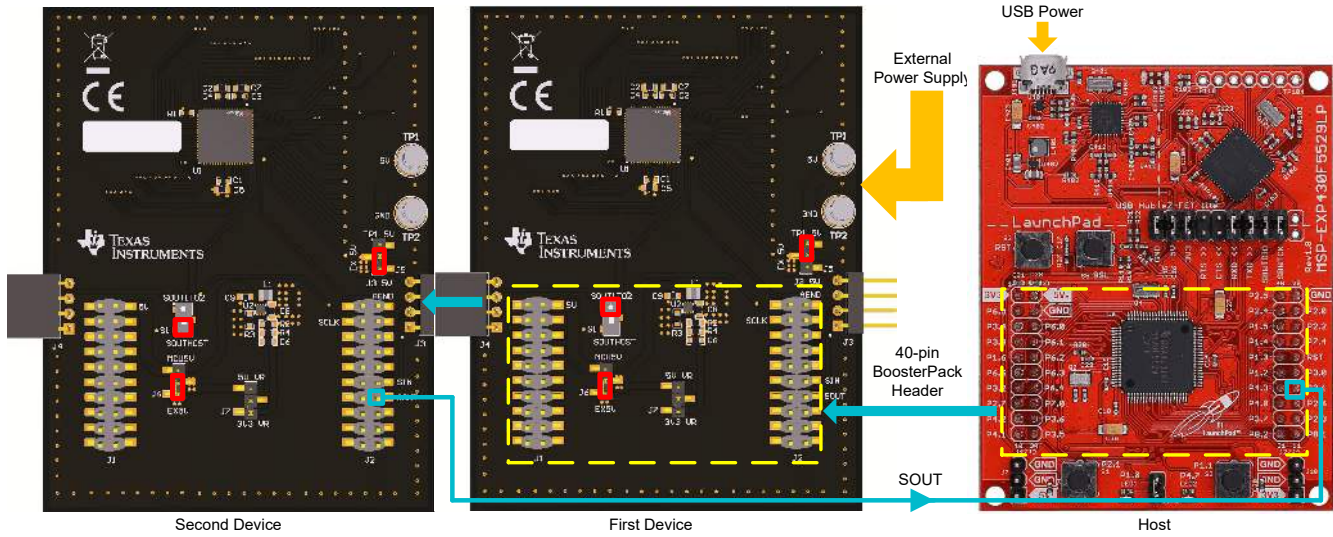

Figure 3-3. Dual Cascaded LP5890EVM Connected with the MSP430F5529 LaunchPad

4 Additional Resources

More information about the LP5890 can be found at:

- [LP5890 data sheet, product information and support | TI.com](#)
- [LP5890EVM Evaluation board | TI.com](#)
- [\[FAQ\] How to master LP589x / TLC698x devices with LED display applications within five minutes? - Power management forum - Power management - TI E2E support forums](#)

5 Schematic

The schematic of the EVM is shown below.

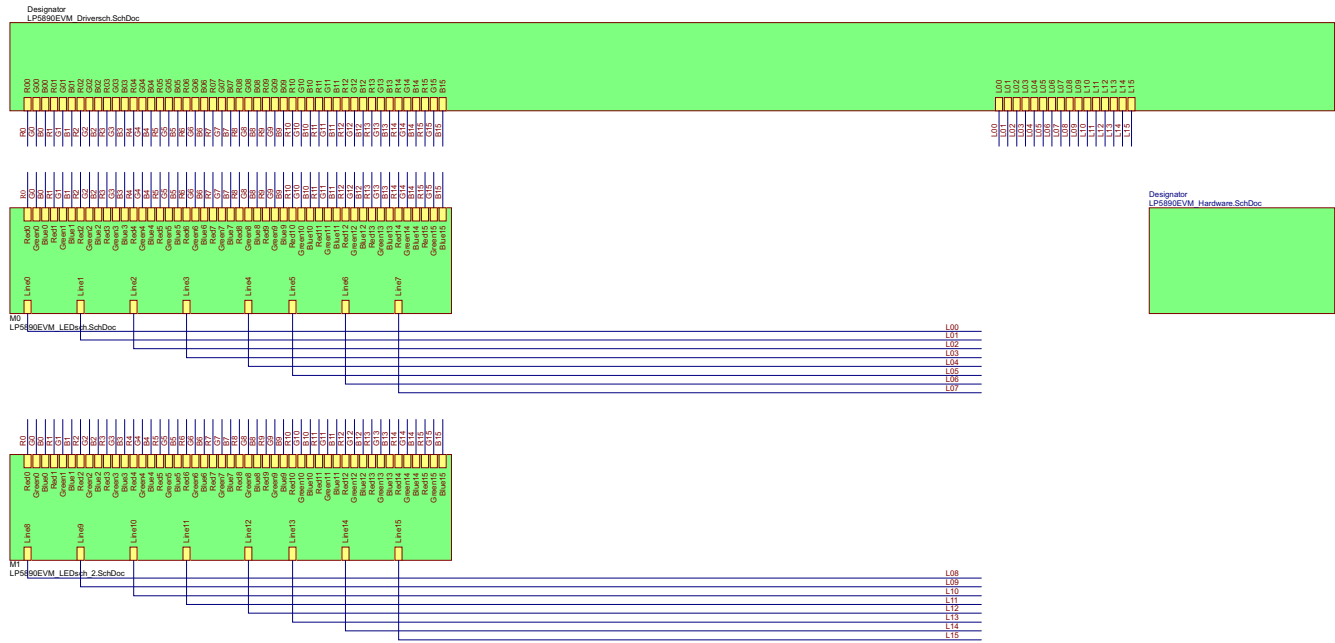

Figure 5-1. LP5890EVM Schematic (1 of 4)

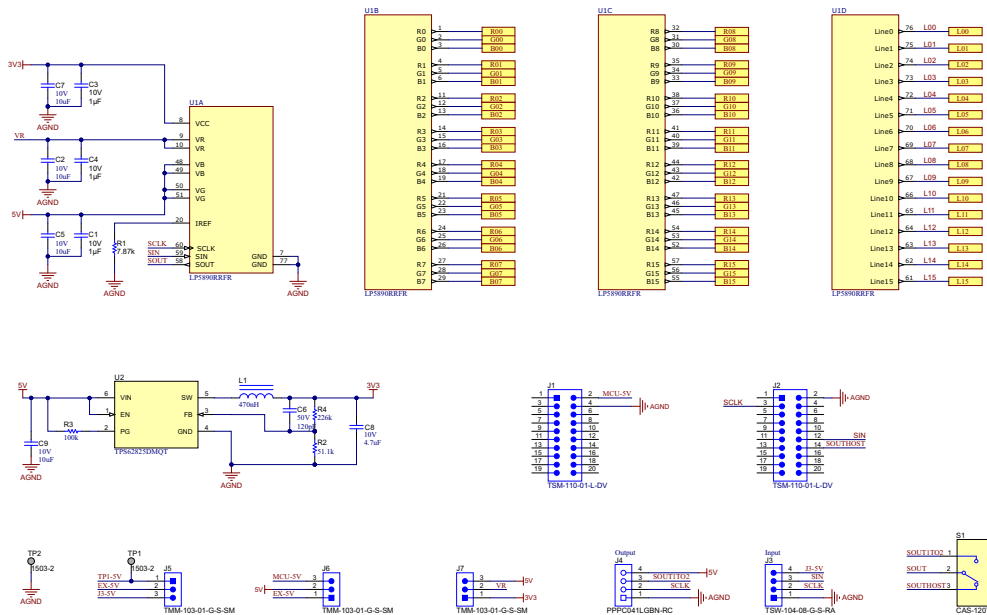

Figure 5-2. LP5890EVM Schematic (2 of 4)

Schematic

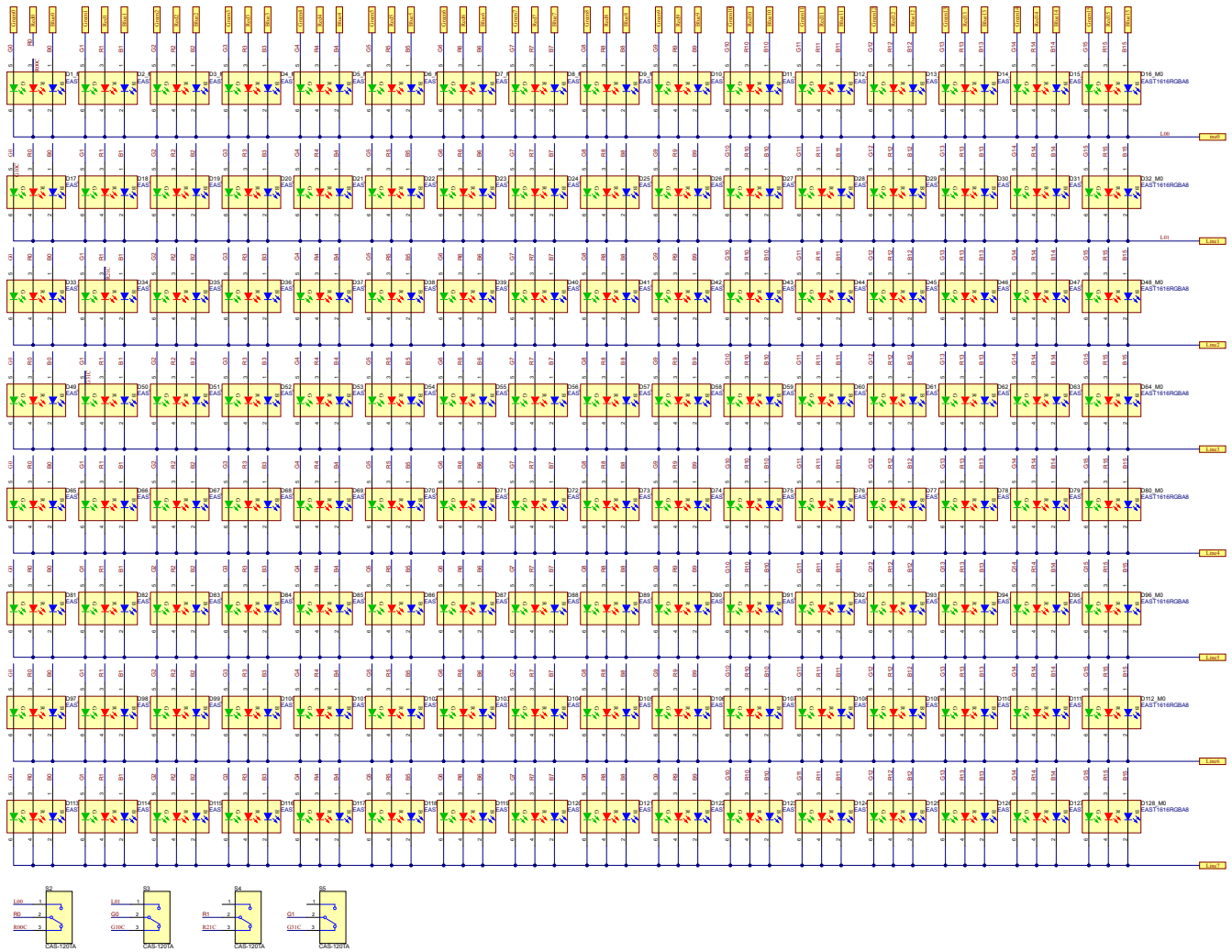

Figure 5-3. LP5890EVM Schematic (3 of 4)



Figure 5-4. LP5890EVM Schematic (4 of 4)

6 Layout

The PCB layout of the EVM is shown below.

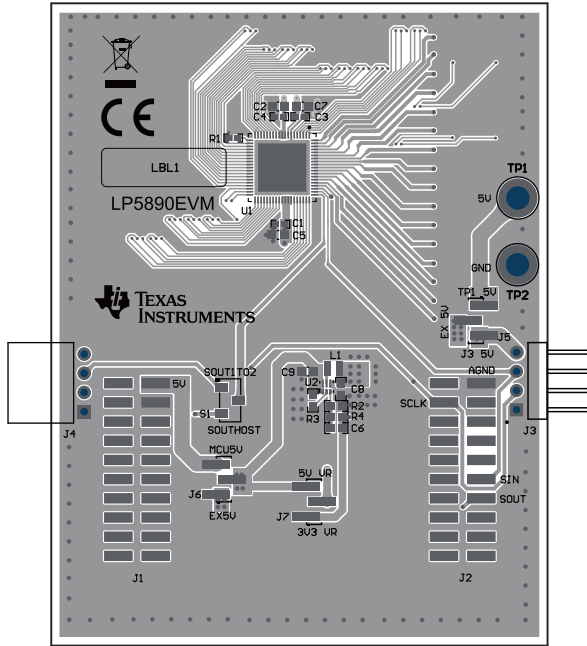

Figure 6-1. LP5890EVM Top Layer

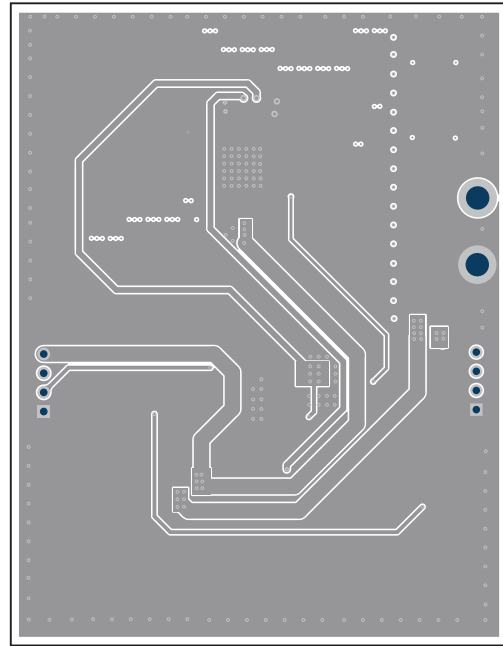

Figure 6-2. LP5890EVM Signal Layer 1

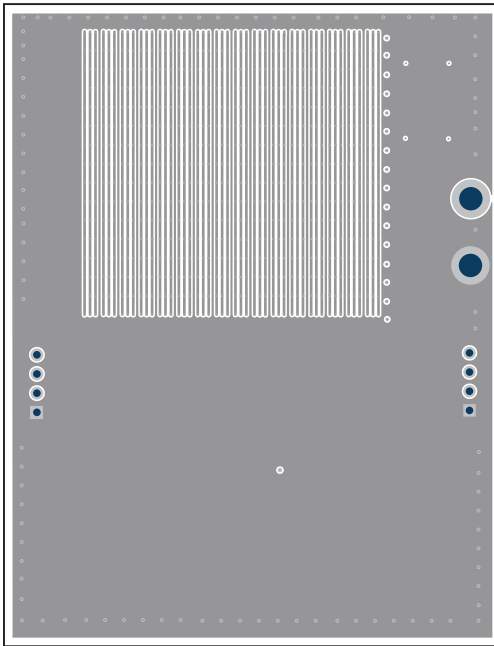

Figure 6-3. LP5890EVM Signal Layer 2

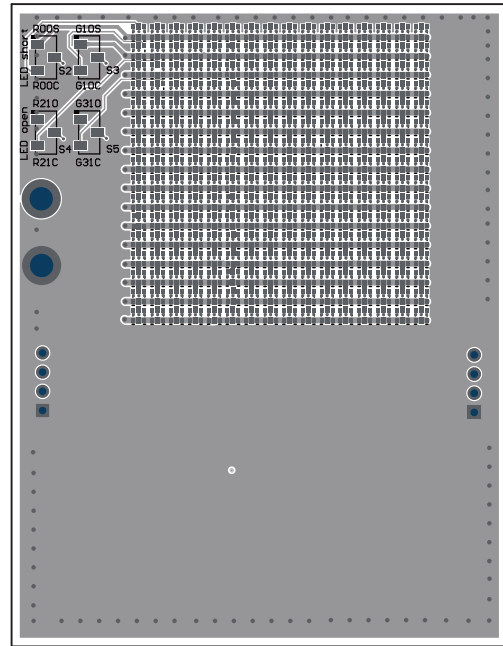

Figure 6-4. LP5890EVM Bottom Layer

7 Bill of Materials

Table 7-1 lists the bill of materials for LP5890EVM.

Table 7-1. Bill of Materials

Designator	Qty.	Description	Part Number	Manufacturer
C1, C3, C4	3	CAP, CERM, 1 μ F, 10 V, \pm 20%, X5R, 0402	CC0402MRX5R6BB105	Yageo America
C2, C5, C7, C9	4	CAP, CERM, 10 μ F, 10 V, \pm 10%, X7T, 0603	ZRB18AD71A106KE01L	MuRata
C6	1	CAP, CERM, 120 pF, 50 V, \pm 1%, C0G/NP0, 0603	VJ0603A121FXACW1BC	Vishay-Sprague
C8	1	CAP, CERM, 4.7 μ F, 10 V, \pm 10%, X5R, 0603	CGB3B1X5R1A475K055AC	TDK
D1_M0... D128_M1	256	LED, RGB, SMD	EAST1616RGBA8	Everlight
J1, J2	2	Header, 2.54mm, 10x2, Gold, SMT	TSM-110-01-L-DV	Samtec
J3	1	Header, 100mil, 4x1, Gold, R/A, TH	TSW-104-08-G-S-RA	Samtec
J4	1	Receptacle, 100mil, 4x1, Gold, R/A, TH	PPPC041LGBN-RC	Sullins Connector Solutions
J5, J6, J7	3	Header, 2 mm, 3x1, Gold, SMT	TMM-103-01-G-S-SM	Samtec
L1	1	Inductor, Shielded, Metal Composite, 470 nH, 3.6 A, 0.032 ohm, SMD	DFE201610E-R47M=P2	MuRata
LBL1	1	Thermal Transfer Printable Labels, 0.650" W x 0.200" H - 10,000 per roll	THT-14-423-10	Brady
R1	1	RES, 7.87 k, 1%, 0.063 W, AEC-Q200 Grade 0, 0402	CRCW04027K87FKED	Vishay-Dale
R2	1	RES, 51.1 k, 0.1%, 0.1 W, 0603	RT0603BRD0751K1L	Yageo America
R3	1	RES, 100 k, 1%, 0.1 W, AEC-Q200 Grade 0, 0603	CRCW0603100KFKEA	Vishay-Dale
R4	1	RES, 226 k, 1%, 0.1 W, AEC-Q200 Grade 0, 0603	CRCW0603226KFKEA	Vishay-Dale
S1, S2, S3, S4, S5	5	Switch, Slide, SPDT 100 mA, SMT	CAS-120TA	Copal Electronics
SH-J1, SH-J2, SH-J3	3	Shunt, 2 mm, Gold plated, Black	2SN-BK-G	Samtec
TP1, TP2	2	Terminal, Turret, TH, Double	1503-2	Keystone
U1	1	48 Current Sources, 32 Scans, Common Cathode Matrix LED Display Driver	LP5890RRFR	Texas Instruments
U2	1	2-A High Efficiency Synchronous Buck Converter, DMQ0006A (VSON-HR-6)	TPS62825DMQT	Texas Instruments

STANDARD TERMS FOR EVALUATION MODULES

1. *Delivery:* TI delivers TI evaluation boards, kits, or modules, including any accompanying demonstration software, components, and/or documentation which may be provided together or separately (collectively, an "EVM" or "EVMs") to the User ("User") in accordance with the terms set forth herein. User's acceptance of the EVM is expressly subject to the following terms.
 - 1.1 EVMs are intended solely for product or software developers for use in a research and development setting to facilitate feasibility evaluation, experimentation, or scientific analysis of TI semiconductors products. EVMs have no direct function and are not finished products. EVMs shall not be directly or indirectly assembled as a part or subassembly in any finished product. For clarification, any software or software tools provided with the EVM ("Software") shall not be subject to the terms and conditions set forth herein but rather shall be subject to the applicable terms that accompany such Software
 - 1.2 EVMs are not intended for consumer or household use. EVMs may not be sold, sublicensed, leased, rented, loaned, assigned, or otherwise distributed for commercial purposes by Users, in whole or in part, or used in any finished product or production system.
2. *Limited Warranty and Related Remedies/Disclaimers:*
 - 2.1 These terms do not apply to Software. The warranty, if any, for Software is covered in the applicable Software License Agreement.
 - 2.2 TI warrants that the TI EVM will conform to TI's published specifications for ninety (90) days after the date TI delivers such EVM to User. Notwithstanding the foregoing, TI shall not be liable for a nonconforming EVM if (a) the nonconformity was caused by neglect, misuse or mistreatment by an entity other than TI, including improper installation or testing, or for any EVMs that have been altered or modified in any way by an entity other than TI, (b) the nonconformity resulted from User's design, specifications or instructions for such EVMs or improper system design, or (c) User has not paid on time. Testing and other quality control techniques are used to the extent TI deems necessary. TI does not test all parameters of each EVM. User's claims against TI under this Section 2 are void if User fails to notify TI of any apparent defects in the EVMs within ten (10) business days after delivery, or of any hidden defects with ten (10) business days after the defect has been detected.
 - 2.3 TI's sole liability shall be at its option to repair or replace EVMs that fail to conform to the warranty set forth above, or credit User's account for such EVM. TI's liability under this warranty shall be limited to EVMs that are returned during the warranty period to the address designated by TI and that are determined by TI not to conform to such warranty. If TI elects to repair or replace such EVM, TI shall have a reasonable time to repair such EVM or provide replacements. Repaired EVMs shall be warranted for the remainder of the original warranty period. Replaced EVMs shall be warranted for a new full ninety (90) day warranty period.

WARNING

Evaluation Kits are intended solely for use by technically qualified, professional electronics experts who are familiar with the dangers and application risks associated with handling electrical mechanical components, systems, and subsystems.

User shall operate the Evaluation Kit within TI's recommended guidelines and any applicable legal or environmental requirements as well as reasonable and customary safeguards. Failure to set up and/or operate the Evaluation Kit within TI's recommended guidelines may result in personal injury or death or property damage. Proper set up entails following TI's instructions for electrical ratings of interface circuits such as input, output and electrical loads.

NOTE:

EXPOSURE TO ELECTROSTATIC DISCHARGE (ESD) MAY CAUSE DEGRADATION OR FAILURE OF THE EVALUATION KIT; TI RECOMMENDS STORAGE OF THE EVALUATION KIT IN A PROTECTIVE ESD BAG.

3 Regulatory Notices:

3.1 United States

3.1.1 Notice applicable to EVMs not FCC-Approved:

FCC NOTICE: This kit is designed to allow product developers to evaluate electronic components, circuitry, or software associated with the kit to determine whether to incorporate such items in a finished product and software developers to write software applications for use with the end product. This kit is not a finished product and when assembled may not be resold or otherwise marketed unless all required FCC equipment authorizations are first obtained. Operation is subject to the condition that this product not cause harmful interference to licensed radio stations and that this product accept harmful interference. Unless the assembled kit is designed to operate under part 15, part 18 or part 95 of this chapter, the operator of the kit must operate under the authority of an FCC license holder or must secure an experimental authorization under part 5 of this chapter.

3.1.2 For EVMs annotated as FCC – FEDERAL COMMUNICATIONS COMMISSION Part 15 Compliant:

CAUTION

This device complies with part 15 of the FCC Rules. Operation is subject to the following two conditions: (1) This device may not cause harmful interference, and (2) this device must accept any interference received, including interference that may cause undesired operation.

Changes or modifications not expressly approved by the party responsible for compliance could void the user's authority to operate the equipment.

FCC Interference Statement for Class A EVM devices

NOTE: This equipment has been tested and found to comply with the limits for a Class A digital device, pursuant to part 15 of the FCC Rules. These limits are designed to provide reasonable protection against harmful interference when the equipment is operated in a commercial environment. This equipment generates, uses, and can radiate radio frequency energy and, if not installed and used in accordance with the instruction manual, may cause harmful interference to radio communications. Operation of this equipment in a residential area is likely to cause harmful interference in which case the user will be required to correct the interference at his own expense.

FCC Interference Statement for Class B EVM devices

NOTE: This equipment has been tested and found to comply with the limits for a Class B digital device, pursuant to part 15 of the FCC Rules. These limits are designed to provide reasonable protection against harmful interference in a residential installation. This equipment generates, uses and can radiate radio frequency energy and, if not installed and used in accordance with the instructions, may cause harmful interference to radio communications. However, there is no guarantee that interference will not occur in a particular installation. If this equipment does cause harmful interference to radio or television reception, which can be determined by turning the equipment off and on, the user is encouraged to try to correct the interference by one or more of the following measures:

- Reorient or relocate the receiving antenna.
- Increase the separation between the equipment and receiver.
- Connect the equipment into an outlet on a circuit different from that to which the receiver is connected.
- Consult the dealer or an experienced radio/TV technician for help.

3.2 Canada

3.2.1 For EVMs issued with an Industry Canada Certificate of Conformance to RSS-210 or RSS-247

Concerning EVMs Including Radio Transmitters:

This device complies with Industry Canada license-exempt RSSs. Operation is subject to the following two conditions:

(1) this device may not cause interference, and (2) this device must accept any interference, including interference that may cause undesired operation of the device.

Concernant les EVMs avec appareils radio:

Le présent appareil est conforme aux CNR d'Industrie Canada applicables aux appareils radio exempts de licence. L'exploitation est autorisée aux deux conditions suivantes: (1) l'appareil ne doit pas produire de brouillage, et (2) l'utilisateur de l'appareil doit accepter tout brouillage radioélectrique subi, même si le brouillage est susceptible d'en compromettre le fonctionnement.

Concerning EVMs Including Detachable Antennas:

Under Industry Canada regulations, this radio transmitter may only operate using an antenna of a type and maximum (or lesser) gain approved for the transmitter by Industry Canada. To reduce potential radio interference to other users, the antenna type and its gain should be so chosen that the equivalent isotropically radiated power (e.i.r.p.) is not more than that necessary for successful communication. This radio transmitter has been approved by Industry Canada to operate with the antenna types listed in the user guide with the maximum permissible gain and required antenna impedance for each antenna type indicated. Antenna types not included in this list, having a gain greater than the maximum gain indicated for that type, are strictly prohibited for use with this device.

Concernant les EVMs avec antennes détachables

Conformément à la réglementation d'Industrie Canada, le présent émetteur radio peut fonctionner avec une antenne d'un type et d'un gain maximal (ou inférieur) approuvé pour l'émetteur par Industrie Canada. Dans le but de réduire les risques de brouillage radioélectrique à l'intention des autres utilisateurs, il faut choisir le type d'antenne et son gain de sorte que la puissance isotrope rayonnée équivalente (p.i.r.e.) ne dépasse pas l'intensité nécessaire à l'établissement d'une communication satisfaisante. Le présent émetteur radio a été approuvé par Industrie Canada pour fonctionner avec les types d'antenne énumérés dans le manuel d'usage et ayant un gain admissible maximal et l'impédance requise pour chaque type d'antenne. Les types d'antenne non inclus dans cette liste, ou dont le gain est supérieur au gain maximal indiqué, sont strictement interdits pour l'exploitation de l'émetteur.

3.3 Japan

3.3.1 *Notice for EVMs delivered in Japan:* Please see http://www.tij.co.jp/lstds/ti_ja/general/eStore/notice_01.page 日本国内に輸入される評価用キット、ボードについては、次のところをご覧ください。
http://www.tij.co.jp/lstds/ti_ja/general/eStore/notice_01.page

3.3.2 *Notice for Users of EVMs Considered "Radio Frequency Products" in Japan:* EVMs entering Japan may not be certified by TI as conforming to Technical Regulations of Radio Law of Japan.

If User uses EVMs in Japan, not certified to Technical Regulations of Radio Law of Japan, User is required to follow the instructions set forth by Radio Law of Japan, which includes, but is not limited to, the instructions below with respect to EVMs (which for the avoidance of doubt are stated strictly for convenience and should be verified by User):

1. Use EVMs in a shielded room or any other test facility as defined in the notification #173 issued by Ministry of Internal Affairs and Communications on March 28, 2006, based on Sub-section 1.1 of Article 6 of the Ministry's Rule for Enforcement of Radio Law of Japan,
2. Use EVMs only after User obtains the license of Test Radio Station as provided in Radio Law of Japan with respect to EVMs, or
3. Use of EVMs only after User obtains the Technical Regulations Conformity Certification as provided in Radio Law of Japan with respect to EVMs. Also, do not transfer EVMs, unless User gives the same notice above to the transferee. Please note that if User does not follow the instructions above, User will be subject to penalties of Radio Law of Japan.

【無線電波を送信する製品の開発キットをお使いになる際の注意事項】 開発キットの中には技術基準適合証明を受けていないものがあります。技術適合証明を受けていないものご使用に際しては、電波法遵守のため、以下のいずれかの措置を取っていただく必要がありますのでご注意ください。

1. 電波法施行規則第6条第1項第1号に基づく平成18年3月28日総務省告示第173号で定められた電波暗室等の試験設備でご使用いただく。
2. 実験局の免許を取得後ご使用いただく。
3. 技術基準適合証明を取得後ご使用いただく。

なお、本製品は、上記の「ご使用にあたっての注意」を譲渡先、移転先に通知しない限り、譲渡、移転できないものとします。

上記を遵守頂けない場合は、電波法の罰則が適用される可能性があることをご留意ください。日本テキサス・インスツルメンツ株式会社
東京都新宿区西新宿 6 丁目 2 4 番 1 号
西新宿三井ビル

3.3.3 *Notice for EVMs for Power Line Communication:* Please see http://www.tij.co.jp/lstds/ti_ja/general/eStore/notice_02.page 電力線搬送波通信についての開発キットをお使いになる際の注意事項については、次のところをご覧ください。
http://www.tij.co.jp/lstds/ti_ja/general/eStore/notice_02.page

3.4 European Union

3.4.1 *For EVMs subject to EU Directive 2014/30/EU (Electromagnetic Compatibility Directive):*

This is a class A product intended for use in environments other than domestic environments that are connected to a low-voltage power-supply network that supplies buildings used for domestic purposes. In a domestic environment this product may cause radio interference in which case the user may be required to take adequate measures.

4 *EVM Use Restrictions and Warnings:*

4.1 EVMS ARE NOT FOR USE IN FUNCTIONAL SAFETY AND/OR SAFETY CRITICAL EVALUATIONS, INCLUDING BUT NOT LIMITED TO EVALUATIONS OF LIFE SUPPORT APPLICATIONS.

4.2 User must read and apply the user guide and other available documentation provided by TI regarding the EVM prior to handling or using the EVM, including without limitation any warning or restriction notices. The notices contain important safety information related to, for example, temperatures and voltages.

4.3 *Safety-Related Warnings and Restrictions:*

4.3.1 User shall operate the EVM within TI's recommended specifications and environmental considerations stated in the user guide, other available documentation provided by TI, and any other applicable requirements and employ reasonable and customary safeguards. Exceeding the specified performance ratings and specifications (including but not limited to input and output voltage, current, power, and environmental ranges) for the EVM may cause personal injury or death, or property damage. If there are questions concerning performance ratings and specifications, User should contact a TI field representative prior to connecting interface electronics including input power and intended loads. Any loads applied outside of the specified output range may also result in unintended and/or inaccurate operation and/or possible permanent damage to the EVM and/or interface electronics. Please consult the EVM user guide prior to connecting any load to the EVM output. If there is uncertainty as to the load specification, please contact a TI field representative. During normal operation, even with the inputs and outputs kept within the specified allowable ranges, some circuit components may have elevated case temperatures. These components include but are not limited to linear regulators, switching transistors, pass transistors, current sense resistors, and heat sinks, which can be identified using the information in the associated documentation. When working with the EVM, please be aware that the EVM may become very warm.

4.3.2 EVMs are intended solely for use by technically qualified, professional electronics experts who are familiar with the dangers and application risks associated with handling electrical mechanical components, systems, and subsystems. User assumes all responsibility and liability for proper and safe handling and use of the EVM by User or its employees, affiliates, contractors or designees. User assumes all responsibility and liability to ensure that any interfaces (electronic and/or mechanical) between the EVM and any human body are designed with suitable isolation and means to safely limit accessible leakage currents to minimize the risk of electrical shock hazard. User assumes all responsibility and liability for any improper or unsafe handling or use of the EVM by User or its employees, affiliates, contractors or designees.

4.4 User assumes all responsibility and liability to determine whether the EVM is subject to any applicable international, federal, state, or local laws and regulations related to User's handling and use of the EVM and, if applicable, User assumes all responsibility and liability for compliance in all respects with such laws and regulations. User assumes all responsibility and liability for proper disposal and recycling of the EVM consistent with all applicable international, federal, state, and local requirements.

5. *Accuracy of Information:* To the extent TI provides information on the availability and function of EVMs, TI attempts to be as accurate as possible. However, TI does not warrant the accuracy of EVM descriptions, EVM availability or other information on its websites as accurate, complete, reliable, current, or error-free.

6. *Disclaimers:*

6.1 EXCEPT AS SET FORTH ABOVE, EVMS AND ANY MATERIALS PROVIDED WITH THE EVM (INCLUDING, BUT NOT LIMITED TO, REFERENCE DESIGNS AND THE DESIGN OF THE EVM ITSELF) ARE PROVIDED "AS IS" AND "WITH ALL FAULTS." TI DISCLAIMS ALL OTHER WARRANTIES, EXPRESS OR IMPLIED, REGARDING SUCH ITEMS, INCLUDING BUT NOT LIMITED TO ANY EPIDEMIC FAILURE WARRANTY OR IMPLIED WARRANTIES OF MERCHANTABILITY OR FITNESS FOR A PARTICULAR PURPOSE OR NON-INFRINGEMENT OF ANY THIRD PARTY PATENTS, COPYRIGHTS, TRADE SECRETS OR OTHER INTELLECTUAL PROPERTY RIGHTS.

6.2 EXCEPT FOR THE LIMITED RIGHT TO USE THE EVM SET FORTH HEREIN, NOTHING IN THESE TERMS SHALL BE CONSTRUED AS GRANTING OR CONFERRING ANY RIGHTS BY LICENSE, PATENT, OR ANY OTHER INDUSTRIAL OR INTELLECTUAL PROPERTY RIGHT OF TI, ITS SUPPLIERS/LICENSORS OR ANY OTHER THIRD PARTY, TO USE THE EVM IN ANY FINISHED END-USER OR READY-TO-USE FINAL PRODUCT, OR FOR ANY INVENTION, DISCOVERY OR IMPROVEMENT, REGARDLESS OF WHEN MADE, CONCEIVED OR ACQUIRED.

7. *USER'S INDEMNITY OBLIGATIONS AND REPRESENTATIONS.* USER WILL DEFEND, INDEMNIFY AND HOLD TI, ITS LICENSORS AND THEIR REPRESENTATIVES HARMLESS FROM AND AGAINST ANY AND ALL CLAIMS, DAMAGES, LOSSES, EXPENSES, COSTS AND LIABILITIES (COLLECTIVELY, "CLAIMS") ARISING OUT OF OR IN CONNECTION WITH ANY HANDLING OR USE OF THE EVM THAT IS NOT IN ACCORDANCE WITH THESE TERMS. THIS OBLIGATION SHALL APPLY WHETHER CLAIMS ARISE UNDER STATUTE, REGULATION, OR THE LAW OF TORT, CONTRACT OR ANY OTHER LEGAL THEORY, AND EVEN IF THE EVM FAILS TO PERFORM AS DESCRIBED OR EXPECTED.

8. *Limitations on Damages and Liability:*

8.1 *General Limitations.* IN NO EVENT SHALL TI BE LIABLE FOR ANY SPECIAL, COLLATERAL, INDIRECT, PUNITIVE, INCIDENTAL, CONSEQUENTIAL, OR EXEMPLARY DAMAGES IN CONNECTION WITH OR ARISING OUT OF THESE TERMS OR THE USE OF THE EVMS , REGARDLESS OF WHETHER TI HAS BEEN ADVISED OF THE POSSIBILITY OF SUCH DAMAGES. EXCLUDED DAMAGES INCLUDE, BUT ARE NOT LIMITED TO, COST OF REMOVAL OR REINSTALLATION, ANCILLARY COSTS TO THE PROCUREMENT OF SUBSTITUTE GOODS OR SERVICES, RETESTING, OUTSIDE COMPUTER TIME, LABOR COSTS, LOSS OF GOODWILL, LOSS OF PROFITS, LOSS OF SAVINGS, LOSS OF USE, LOSS OF DATA, OR BUSINESS INTERRUPTION. NO CLAIM, SUIT OR ACTION SHALL BE BROUGHT AGAINST TI MORE THAN TWELVE (12) MONTHS AFTER THE EVENT THAT GAVE RISE TO THE CAUSE OF ACTION HAS OCCURRED.

8.2 *Specific Limitations.* IN NO EVENT SHALL TI'S AGGREGATE LIABILITY FROM ANY USE OF AN EVM PROVIDED HEREUNDER, INCLUDING FROM ANY WARRANTY, INDEMNITY OR OTHER OBLIGATION ARISING OUT OF OR IN CONNECTION WITH THESE TERMS, , EXCEED THE TOTAL AMOUNT PAID TO TI BY USER FOR THE PARTICULAR EVM(S) AT ISSUE DURING THE PRIOR TWELVE (12) MONTHS WITH RESPECT TO WHICH LOSSES OR DAMAGES ARE CLAIMED. THE EXISTENCE OF MORE THAN ONE CLAIM SHALL NOT ENLARGE OR EXTEND THIS LIMIT.

9. *Return Policy.* Except as otherwise provided, TI does not offer any refunds, returns, or exchanges. Furthermore, no return of EVM(s) will be accepted if the package has been opened and no return of the EVM(s) will be accepted if they are damaged or otherwise not in a resalable condition. If User feels it has been incorrectly charged for the EVM(s) it ordered or that delivery violates the applicable order, User should contact TI. All refunds will be made in full within thirty (30) working days from the return of the components(s), excluding any postage or packaging costs.

10. *Governing Law:* These terms and conditions shall be governed by and interpreted in accordance with the laws of the State of Texas, without reference to conflict-of-laws principles. User agrees that non-exclusive jurisdiction for any dispute arising out of or relating to these terms and conditions lies within courts located in the State of Texas and consents to venue in Dallas County, Texas. Notwithstanding the foregoing, any judgment may be enforced in any United States or foreign court, and TI may seek injunctive relief in any United States or foreign court.

Mailing Address: Texas Instruments, Post Office Box 655303, Dallas, Texas 75265
Copyright © 2019, Texas Instruments Incorporated

IMPORTANT NOTICE AND DISCLAIMER

TI PROVIDES TECHNICAL AND RELIABILITY DATA (INCLUDING DATA SHEETS), DESIGN RESOURCES (INCLUDING REFERENCE DESIGNS), APPLICATION OR OTHER DESIGN ADVICE, WEB TOOLS, SAFETY INFORMATION, AND OTHER RESOURCES "AS IS" AND WITH ALL FAULTS, AND DISCLAIMS ALL WARRANTIES, EXPRESS AND IMPLIED, INCLUDING WITHOUT LIMITATION ANY IMPLIED WARRANTIES OF MERCHANTABILITY, FITNESS FOR A PARTICULAR PURPOSE OR NON-INFRINGEMENT OF THIRD PARTY INTELLECTUAL PROPERTY RIGHTS.

These resources are intended for skilled developers designing with TI products. You are solely responsible for (1) selecting the appropriate TI products for your application, (2) designing, validating and testing your application, and (3) ensuring your application meets applicable standards, and any other safety, security, regulatory or other requirements.

These resources are subject to change without notice. TI grants you permission to use these resources only for development of an application that uses the TI products described in the resource. Other reproduction and display of these resources is prohibited. No license is granted to any other TI intellectual property right or to any third party intellectual property right. TI disclaims responsibility for, and you will fully indemnify TI and its representatives against, any claims, damages, costs, losses, and liabilities arising out of your use of these resources.

TI's products are provided subject to [TI's Terms of Sale](#) or other applicable terms available either on ti.com or provided in conjunction with such TI products. TI's provision of these resources does not expand or otherwise alter TI's applicable warranties or warranty disclaimers for TI products.

TI objects to and rejects any additional or different terms you may have proposed.

Mailing Address: Texas Instruments, Post Office Box 655303, Dallas, Texas 75265
Copyright © 2022, Texas Instruments Incorporated