

450MHz CDMA/OFDM LNA/Mixer

General Description

The MAX2335 RF front-end receiver IC is designed for CDMA and OFDM applications in the 450MHz band.

The MAX2335 includes a low-noise amplifier (LNA) with adjustable IIP3 to minimize desensitization due to cross-modulation in the presence of a large interfering signal.

The mixer features differential IF outputs and is designed for high linearity and low noise, which is well suited for CDMA and OFDM applications.

An on-chip frequency divider is included to allow the use of a standard 1GHz VCO. Alternatively, the divider can be bypassed for use with a lower-frequency VCO.

The MAX2335 is available in a 28-pin TQFN package with exposed paddle and is specified for the -40°C to +85°C extended temperature range. The device is also offered in a lead-free package.

Applications

450MHz-Band, WCDMA, IS-95, IS-2000, OFDM, Wireless Data Links

Features

- ◆ 1.5dB LNA Noise Figure
- ◆ 16dB LNA Gain
- ◆ 2.1dB Cascaded Noise Figure
- ◆ Adjustable LNA IIP3
- ◆ LO Output Buffer for Transmitter
- ◆ LO Frequency Divider
- ◆ Small 5mm x 5mm, 28-Pin (Lead-Free) TQFN Package

Ordering Information

PART	TEMP RANGE	PIN-PACKAGE	PKG CODE
MAX2335ETI	-40°C to +85°C	28 Thin QFN-EP* (5mm x 5mm)	T2855-3
MAX2335ETI+	-40°C to +85°C	28 Thin QFN-EP* (5mm x 5mm)	T2855+3

*EP = Exposed paddle.

+Denotes lead-free package.

Pin Configuration/ Functional Diagram

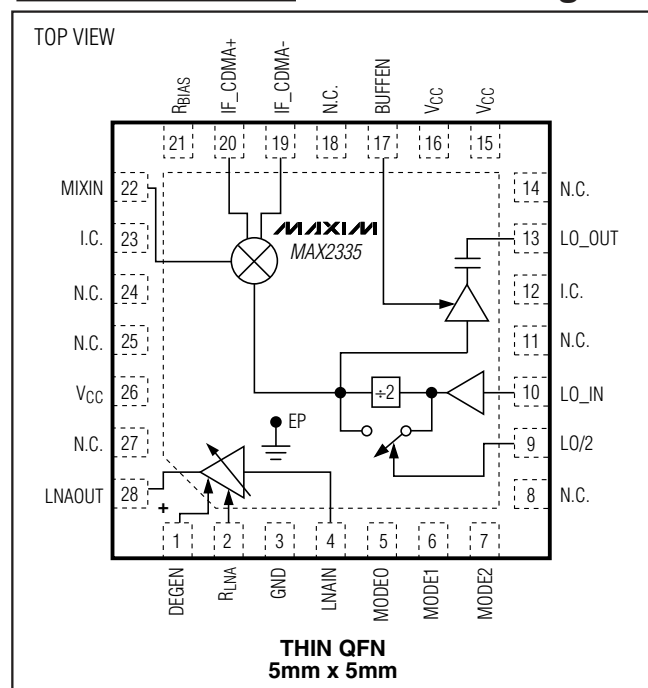

450MHz CDMA/OFDM LNA/Mixer

ABSOLUTE MAXIMUM RATINGS

V_{CC} to GND-0.3V to +4.3V
 All Other Pins to GND-0.3V to (V_{CC} + 0.3V)
 AC Input Pins (LNAIN, LO_IN, MIXIN) to GND1V Peak
 Continuous Power Dissipation (T_A = +70°C)
 28-Pin Thin QFN (derate 34.5mW/°C above +70°C)2.7W

Operating Temperature Range-40°C to +85°C
 Junction Temperature+150°C
 Storage Temperature Range-65°C to +150°C
 Lead Temperature (soldering, 10s)+300°C

Stresses beyond those listed under "Absolute Maximum Ratings" may cause permanent damage to the device. These are stress ratings only, and functional operation of the device at these or any other conditions beyond those indicated in the operational sections of the specifications is not implied. Exposure to absolute maximum rating conditions for extended periods may affect device reliability.



DC ELECTRICAL CHARACTERISTICS

(V_{CC} = +2.9V to +3.3V, R_{BIAS} = 18kΩ, R_{LNA} = 24kΩ, BUFFEN = LOW, LO/2 = HIGH, T_A = -40°C to +85°C, unless otherwise noted. Typical values are at V_{CC} = +2.9V, LOW = 0V, HIGH = +3.0V, T_A = +25°C, unless otherwise noted.) (Note 1)

PARAMETER	SYMBOL	CONDITIONS	MIN	TYP	MAX	UNITS
Operating Supply Current	I _{CC}	HGHL mode (MODE[2:0] = 111)		32	38	mA
		HGLL mode (MODE[2:0] = 101)		24	29	
		LG mode (MODE[2:0] = 011)		27	31	
Shutdown Supply Current	I _{CC}	Shutdown mode (MODE[2:0] = 000)		0.2	10	μA
LO Buffer Supply Current	I _{CC}	Addition for BUFFEN = HIGH		7	13	mA
Digital Input-Logic High	V _{IH}		2			V
Digital Input-Logic Low	V _{IL}				0.6	V
Digital Input Current (Logic-High)	I _{IH}				5	μA
Digital Input Current (Logic-Low)	I _{IL}		-25			μA

AC ELECTRICAL CHARACTERISTICS

(MAX2335 EV Kit, V_{CC} = +2.9V to +3.3V, f_{LNAIN} = f_{MIXIN} = 465MHz, f_{IF} = 110MHz, f_{LO} = 2 x (f_{MIXIN} + f_{IF}), 50Ω system impedance, R_{BIAS} = 18kΩ, R_{LNA} = 24kΩ, cascaded performance includes 2dB interstage filter loss, T_A = -40°C to +85°C, unless otherwise noted. Typical values are at V_{CC} = +2.9V, P_{LO_IN} = -7dBm, LOW = 0V, HIGH = +3.0V, T_A = +25°C, unless otherwise noted.)

PARAMETER	SYMBOL	CONDITIONS	MIN	TYP	MAX	UNITS
OVERALL PERFORMANCE						
RF Frequency Range	f _{RF}			420 to 470		MHz
LO Frequency Range	f _{LO}	After optional LO/2		500 to 660		MHz
IF Frequency Range	f _{IF}			80 to 190		MHz
LO Input Power		(Note 2)	-7	-3	0	dBm
LO Buffer Output Power		BUFFEN = HIGH	-10	-6		dBm
Return Loss		All modes, all active ports, including 2-element matching network, if necessary		10		dB
CASCADED PERFORMANCE						
HIGH-GAIN, HIGH-LINEARITY MODE (MODE[2:0] = 111)						
Gain	G	(Note 1)	23.0	27	31.5	dB
Noise Figure	NF	Including off-chip matching, T _A = +25°C (Note 2)		2.2	2.6	dB
Input Third-Order Intercept Point	IIP3	T _A = +25°C (Notes 1, 3)	-14	-11.5		dBm

450MHz CDMA/OFDM LNA/Mixer

MAX2335

AC ELECTRICAL CHARACTERISTICS (continued)

(MAX2335 EV Kit, $V_{CC} = +2.9V$ to $+3.3V$, $f_{LNAIN} = f_{MIXIN} = 465MHz$, $f_{IF} = 110MHz$, $f_{LO} = 2 \times (f_{MIXIN} + f_{IF})$, 50Ω system impedance, $R_{BIAS} = 18k\Omega$, $R_{LNA} = 24k\Omega$, cascaded performance includes 2dB interstage filter loss, $T_A = -40^\circ C$ to $+85^\circ C$, unless otherwise noted. Typical values are at $V_{CC} = +2.9V$, $P_{LO_IN} = -7dBm$, $LOW = 0V$, $HIGH = +3.0V$, $T_A = +25^\circ C$, unless otherwise noted.)

PARAMETER	SYMBOL	CONDITIONS	MIN	TYP	MAX	UNITS
HIGH-GAIN, LOW-LINEARITY MODE (MODE[2:0] = 101)						
Gain	G	(Note 1)	21.0	26.5	30.5	dB
Noise Figure	NF	Including off-chip matching, $T_A = +25^\circ C$ (Note 2)		2.1	2.5	dB
Input Third-Order Intercept Point	IIP3	$T_A = +25^\circ C$ (Notes 1, 3)	-15	-12.5		dBm
LOW-GAIN MODE (MODE[2:0] = 011)						
Gain	G	(Note 1)	5	9	14	dB
Noise Figure	NF	Including off-chip matching, $T_A = +25^\circ C$ (Note 2)		12	15	dB
Input Third-Order Intercept Point	IIP3	$T_A = +25^\circ C$ (Notes 1, 3)	3	7		dBm
LNA PERFORMANCE						
HIGH-GAIN, HIGH-LINEARITY MODE (MODE[2:0] = 111)						
Gain	G_{LNA}			15.5		dB
Noise Figure	NF_{LNA}	Including off-chip matching		1.7		dB
Input Third-Order Intercept Point	$IIP3_{LNA}$	(Note 3)		+7		dBm
HIGH-GAIN, LOW-LINEARITY MODE (MODE[2:0] = 101)						
Gain	G_{LNA}			14.5		dB
Noise Figure	NF_{LNA}	Including off-chip matching		1.5		dB
Input Third-Order Intercept Point	$IIP3_{LNA}$	(Note 3)		+5		dBm
LOW-GAIN MODE (MODE[2:0] = 011)						
Gain	G_{LNA}			-2.7		dB
Noise Figure	NF_{LNA}	Including off-chip matching		5.5		dB
Input Third-Order Intercept Point	$IIP3_{LNA}$	(Note 3)		+14		dBm
MIXER PERFORMANCE						
HIGH-GAIN, HIGH-LINEARITY MODE (MODE[2:0] = 111)						
Gain	G_{MIXER}			14		dB
Noise Figure	NF_{MIXER}	Including off-chip matching		7		dB
Input Third-Order Intercept Point	$IIP3_{MIXER}$	(Note 3)		+2		dBm
HIGH-GAIN, LOW-LINEARITY MODE (MODE[2:0] = 101)						
Gain	G_{MIXER}			13.5		dB
Noise Figure	NF_{MIXER}	Including off-chip matching		6.7		dB
Input Third-Order Intercept Point	$IIP3_{MIXER}$	(Note 3)		0		dBm
LOW-GAIN MODE (MODE[2:0] = 011)						
Gain	G_{MIXER}			14		dB
Noise Figure	NF_{MIXER}	Including off-chip matching		7		dB
Input Third-Order Intercept Point	$IIP3_{MIXER}$	(Note 3)		+2		dBm

Note 1: Specifications at $T_A = +25^\circ C$ and $+85^\circ C$ are guaranteed by production test. Specifications at $T_A = -40^\circ C$ are guaranteed by design and characterization.

Note 2: Guaranteed by design and characterization.

Note 3: Two-tone IIP3 tested at $f_{RF1} = 465.9MHz$ and $f_{RF2} = 466.7MHz$ at $-25dBm/$ tone.

450MHz CDMA/OFDM LNA/Mixer

Typical Operating Characteristics

(MAX2335 EV Kit, $V_{CC} = +2.9V$, $f_{LNAIN} = 465MHz$, $f_{IF} = 110MHz$, $f_{LO_IN} = 1150MHz$, $P_{LO_IN} = -7dBm$, $R_{BIAS} = 18k\Omega$, $R_{LNA} = 24k\Omega$, $T_A = +25^\circ C$, unless otherwise noted.)

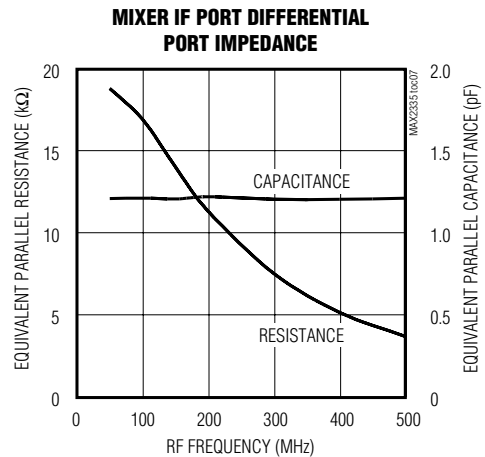
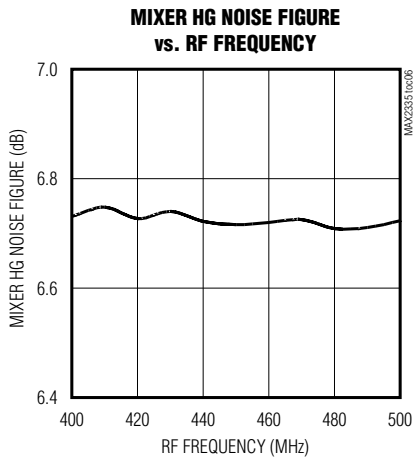
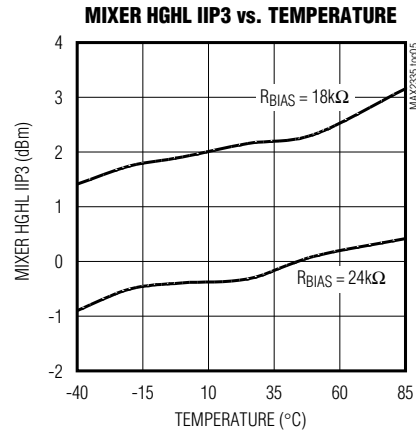
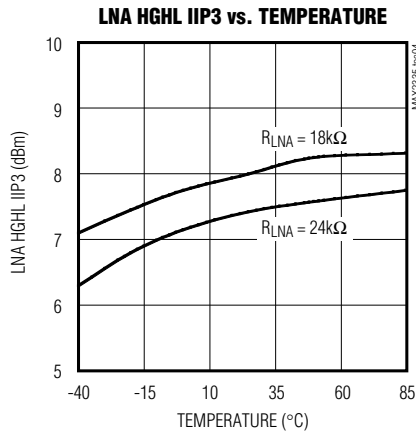
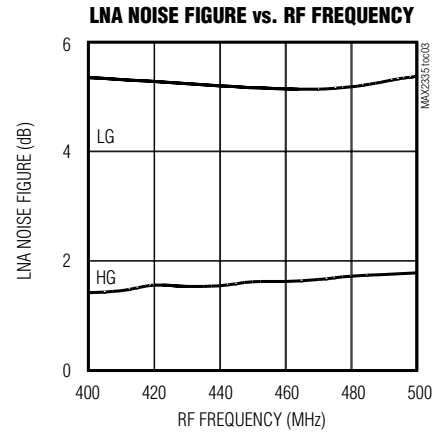
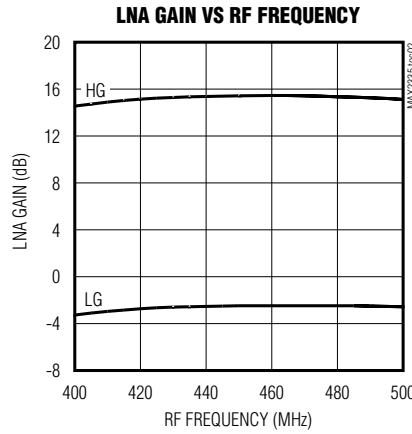
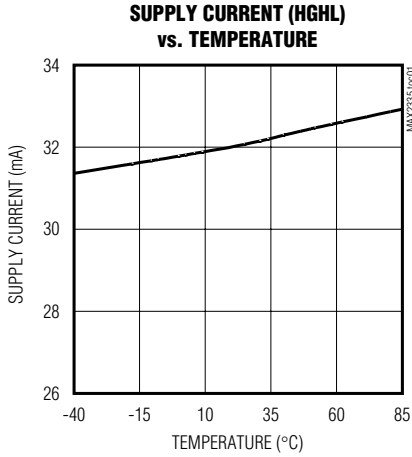

450MHz CDMA/OFDM LNA/Mixer

Pin Description

MAX2335

PIN	NAME	DESCRIPTION
1	DEGEN	LNA Degeneration. Connect a 1nH to 3nH inductor from DEGEN to ground.
2	R _{LNA}	LNA Bias. Connect an 18k Ω to 24k Ω resistor from R _{LNA} to ground. Adjust R _{LNA} to adjust the linearity of the input LNA in the HGHL mode.
3	GND	Ground. Connect to PC board ground plane using low-inductance vias.
4	LNAIN	RF Input. Requires a DC-blocking capacitor, which can be used as part of the matching network.
5	MODE0	Logic Input. See Table 1.
6	MODE1	Logic Input. See Table 1.
7	MODE2	Logic Input. See Table 1.
8, 11, 14, 18, 24, 25, 27	N.C.	No Connection. These pins are internally unconnected. Connect to the PC board ground plane.
9	LO/2	Logic Input. Drive low to disable the LO/2. Drive high to enable the LO/2.
10	LO_IN	LO Input. Internally matched to 50 Ω . Requires an external DC-blocking capacitor. The LO input frequency can be internally divided by two prior to application to the mixer by driving LO/2 high.
12, 23	I.C.	Internally Connected. Leave these pins unconnected for proper operation.
13	LO_OUT	LO Buffer Output. Internally matched to 50 Ω . Does not require a DC-blocking capacitor. The output frequency of the buffer is equal to the LO frequency divided by two when LO/2 is high, or the LO frequency when LO/2 is low.
15, 16, 26	V _{CC}	Power Supply. Bypass pins 16 and 26 to the PC board ground with a capacitor placed as close to the pin as possible. Do not share capacitor ground vias with other ground connections.
17	BUFFEN	LO Output Buffer Enable. Drive high to enable the LO output buffer. Drive low to disable the LO output buffer.
19, 20	IF_CDMA-, IF_CDMA+	Differential IF Output Port. Requires pullup inductors to V _{CC} , which can be used as part of the matching network.
21	R _{BIAS}	Bias Resistor Connection. Connect an 18k Ω to 24k Ω resistor from R _{BIAS} to ground. Adjust R _{BIAS} to adjust the linearity of the input LNA in all modes except HGHL and the mixer in all modes.
22	MIXIN	Mixer Input. Requires an external matching network
28	LNAOUT	LNA Output. Requires an external pullup inductor to V _{CC} and a DC-blocking capacitor, both of which can be used as part of the matching network.
—	EP	Exposed-Paddle Ground Connection. Solder the exposed paddle (EP) evenly to the board's ground plane for proper operation.

450MHz CDMA/OFDM LNA/Mixer

Detailed Description

Low-Noise Amplifiers (LNAs)

The MAX2335's LNA gain and linearity characteristics can be adjusted using the MODE[2:0] inputs. See Table 1 for the pin settings for various operating modes. Use high-gain, high-linearity mode (HGHL) when extra-high linearity is required for cross-modulation suppression in the presence of strong interfering signals (e.g., when the system transmitter is on). Use high-gain, low-linearity mode (HGLL) when the transmitter is off and cross-modulation is not a concern, and use low-gain mode (LG) when receiving large signals. RLNA can be adjusted to vary the current and linearity of the HGHL LNA. RBIAS adjusts the current and the linearity of the HGLL and LG LNA.

Downconverter

The mixer requires a DC-blocking capacitor at the input and pullup inductors at the output. The DC-blocking capacitors and pullup inductors can be designed to be part of the matching circuits. See Table 1 for the MODE settings for various operating modes.

LO Output Buffer

The LO output buffer is internally matched to 50Ω and includes a DC-blocking capacitor. Enable the buffer by driving the BUFFEN input high; disable the buffer by driving the BUFFEN input low. The frequency of the buffer output is equal to the LO frequency if the LO/2 input is driven low, or equal to the LO frequency divided by two if LO/2 is driven high.

Applications Information

Cascaded LNA/Mixer Performance

The LNA and mixer design optimizes cascaded performance in all gain and linearity modes. In HGHL mode, both the LNA and mixer have a low noise figure, high gain, and high linearity. The LNA has high gain to minimize the noise contribution of the mixer, thus increasing the receiver's sensitivity, and the LNA has high linearity for cross-modulation suppression. The HGLL mode is used when the transmitter is off and cross-modulation is not a concern. In LG mode, the received signal is strong enough that linearity is the primary concern. The LNA gain is reduced to achieve higher system linearity.

S-Parameters

The S-parameters in Tables 2, 3, and 4 can be used to design the RF matching circuits.

Table 1. Operating Modes

MODES	FUNCTION						CONTROL PINS				
	LO/1	LO/2	HGHL LNA	HGLL LNA	LG LNA	HGHL MIXER	HGLL MIXER	MODE2	MODE1	MODE0	LO/2
HGHL (LO Frequency Divided by Two)		✓	✓			✓		1	1	1	1
HGLL (LO Frequency Divided by Two)		✓		✓			✓	1	0	1	1
LG (LO Frequency Divided by Two)		✓			✓	✓		0	1	1	1
HGHL (LO Frequency Undivided)	✓		✓			✓		1	1	1	0
HGLL (LO Frequency Undivided)	✓			✓			✓	1	0	1	0
LG (LO Frequency Undivided)	✓				✓	✓		0	1	1	0
Shutdown Mode								0	0	0	X
Undefined								1	X	0	X
Undefined								X	1	0	X

450MHz CDMA/OFDM LNA/Mixer

MAX2335

Table 2. MAX2335 LNA S-Parameters in HGHL Mode

FREQUENCY (MHz)	S11 (dB)	∠S11 (DEGREES)	S21 (dB)	∠S21 (DEGREES)	S12 (dB)	∠S12 (DEGREES)	S22 (dB)	∠S22 (DEGREES)
50	-0.693	-20.000	22.265	2.173	-45.196	-39.133	-0.607	55.183
100	-1.302	-38.600	21.655	-41.256	-37.836	-83.956	-0.532	10.563
150	-1.957	-54.244	20.037	-68.340	-33.411	-107.964	-0.819	-11.252
200	-2.407	-68.840	18.300	-89.560	-31.340	-124.383	-1.051	-26.637
250	-2.656	-82.550	16.860	-105.680	-29.466	-136.021	-1.250	-39.640
300	-2.813	-97.830	15.354	-120.500	-28.422	-147.784	-1.420	-51.424
350	-2.959	-112.274	14.262	-133.400	-26.605	-161.620	-1.492	-63.020
400	-2.953	-127.226	12.926	-144.921	-25.600	-172.633	-1.590	-73.860
410	-2.944	-130.500	12.710	-146.900	-25.519	-174.766	-1.630	-76.200
420	-2.914	-133.724	12.530	-149.125	-25.062	-177.340	-1.628	-78.540
430	-2.876	-136.800	12.439	-151.380	-24.960	-179.138	-1.634	-80.612
440	-2.878	-139.320	12.220	-153.900	-24.780	177.020	-1.650	-82.870
450	-2.884	-142.833	12.000	-155.650	-24.500	176.320	-1.665	-84.900
460	-2.850	-145.863	11.820	-158.324	-24.465	173.850	-1.667	-87.422
470	-2.828	-149.000	11.550	-160.300	-24.239	171.027	-1.697	-89.183
480	-2.828	-159.962	11.343	-161.928	-24.180	169.065	-1.711	-91.480
490	-2.811	-155.360	11.150	-163.540	-23.736	167.483	-1.720	-93.335
500	-2.763	-158.386	11.060	-165.000	-23.568	164.144	-1.718	-95.970
550	-2.628	-174.012	10.298	-174.600	-22.850	152.660	-1.756	-107.020
600	-2.444	169.970	9.810	178.350	-21.890	139.530	-1.770	-117.930
650	-2.230	153.600	9.255	170.400	-21.400	128.572	-1.778	-129.730
700	-1.989	137.420	9.200	162.304	-20.375	117.290	-1.776	-141.100
750	-1.733	121.170	9.164	154.522	-20.230	106.200	-1.828	-152.555
800	-1.464	104.500	9.470	146.813	-19.626	94.020	-1.778	-164.610
850	-1.236	87.855	9.690	135.700	-19.430	83.711	-1.810	-176.805
900	-0.978	73.488	10.432	127.430	-18.654	70.714	-1.860	170.521
950	-0.889	53.876	10.613	112.950	-18.512	59.976	-1.887	158.326
1000	-0.858	36.186	11.417	101.010	-17.839	45.167	-2.033	145.377

450MHz CDMA/OFDM LNA/Mixer

Power-Supply Layout

To minimize coupling between different sections of the IC, use a star configuration, which has a large decoupling capacitor at a central VCC node. The VCC traces branch out from this node, each going to a separate VCC pin of the MAX2335. At the end of each trace is a bypass capacitor with impedance to ground less than 1Ω at the frequency of interest. This arrangement provides local decoupling at each VCC pin. Use at least one via per bypass capacitor for a low-inductance ground connection. Also, connect the exposed paddle to the PC board GND with multiple vias to provide the lowest inductance ground connection possible.

Table 3. MAX2335 Mixer Input Impedance in HGHL Mode

FREQUENCY (MHz)	S11 (dB)	$\angle S11$ (DEGREES)
400	-1.2	77.23
410	-1.229	74.52
420	-1.247	71.7
430	-1.24	69.124
440	-1.24	66.47
450	-1.25	63.97
460	-1.28	61.455
470	-1.32	58.68
480	-1.33	55.87
490	-1.35	53.565
500	-1.35	50.87

Matching Network Layout

The layout of a matching network can be very sensitive to parasitic circuit elements. To minimize parasitic inductance, keep all traces short and place components as close to the IC as possible.

Use high-Q components for the LNA input-matching network to achieve the lowest possible noise figure. Keep the distance between the differential signal lines at the mixer outputs constant and make both lines of equal length to ensure signal balance.

Chip Information

PROCESS: SiGe

Table 4. MAX2335 Mixer Output Impedance (Shunt RC) in HGHL Mode

IF FREQUENCY (MHz)	EQUIVALENT SHUNT RESISTANCE (k Ω)	EQUIVALENT SHUNT CAPACITANCE (pF)
80	17.7	1.21
100	16.961	1.21
120	15.79	1.21
140	14.616	1.21
160	13.49	1.21
190	11.87	1.21

450MHz CDMA/OFDM LNA/Mixer

Typical Application Circuit

MAX2335

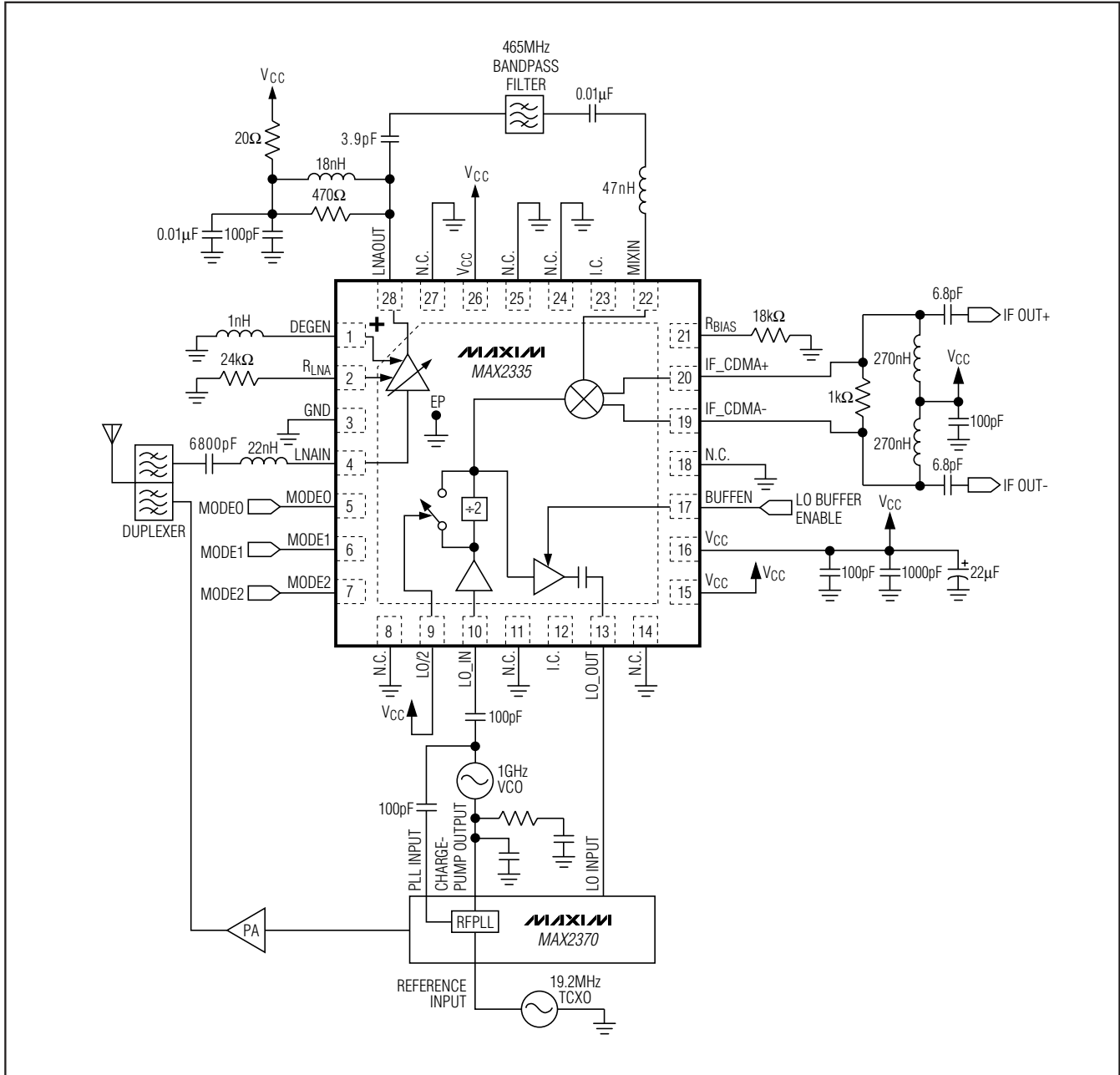

450MHz CDMA/OFDM LNA/Mixer

Package Information

(The package drawing(s) in this data sheet may not reflect the most current specifications. For the latest package outline information go to www.maxim-ic.com/packages.)

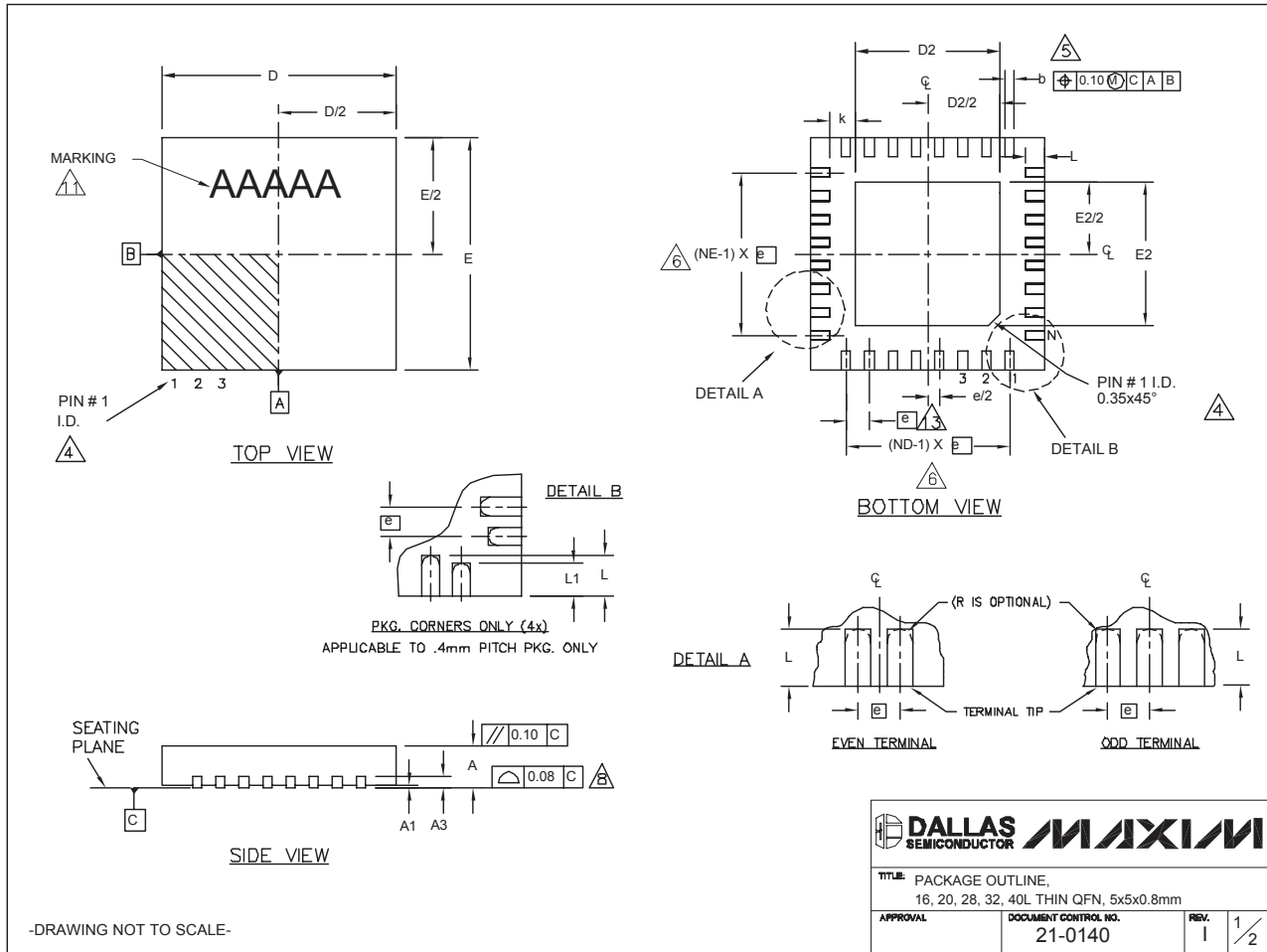

-DRAWING NOT TO SCALE-

450MHz CDMA/OFDM LNA/Mixer

Package Information (continued)

(The package drawing(s) in this data sheet may not reflect the most current specifications. For the latest package outline information go to www.maxim-ic.com/packages.)

MAX2335

COMMON DIMENSIONS															
PKG.	16L 5x5			20L 5x5			28L 5x5			32L 5x5			40L 5x5		
SYMBOL	MIN.	NOM.	MAX.	MIN.	NOM.	MAX.	MIN.	NOM.	MAX.	MIN.	NOM.	MAX.	MIN.	NOM.	MAX.
A	0.70	0.75	0.80	0.70	0.75	0.80	0.70	0.75	0.80	0.70	0.75	0.80	0.70	0.75	0.80
A1	0	0.02	0.05	0	0.02	0.05	0	0.02	0.05	0	0.02	0.05	0	0.02	0.05
A3	0.20 REF.			0.20 REF.			0.20 REF.			0.20 REF.			0.20 REF.		
b	0.25	0.30	0.35	0.25	0.30	0.35	0.20	0.25	0.30	0.20	0.25	0.30	0.15	0.20	0.25
D	4.90	5.00	5.10	4.90	5.00	5.10	4.90	5.00	5.10	4.90	5.00	5.10	4.90	5.00	5.10
E	4.90	5.00	5.10	4.90	5.00	5.10	4.90	5.00	5.10	4.90	5.00	5.10	4.90	5.00	5.10
e	0.80 BSC.			0.65 BSC.			0.50 BSC.			0.50 BSC.			0.40 BSC.		
k	0.25	-	-	0.25	-	-	0.25	-	-	0.25	-	-	0.25	0.35	0.45
L	0.30	0.40	0.50	0.45	0.55	0.65	0.45	0.55	0.65	0.30	0.40	0.50	0.40	0.50	0.60
L1	-	-	-	-	-	-	-	-	-	-	-	-	0.30	0.40	0.50
N	16			20			28			32			40		
ND	4			5			7			8			10		
NE	4			5			7			8			10		
JEDEC	WHHB			WHHC			WHHD-1			WHHD-2			----		

EXPOSED PAD VARIATIONS									
PKG. CODES	D2			E2			L exceptions ±0.15	DOWN BONDS ALLOWED	
	MIN.	NOM.	MAX.	MIN.	NOM.	MAX.			
T1655-2	3.00	3.10	3.20	3.00	3.10	3.20	**	YES	
T1655-3	3.00	3.10	3.20	3.00	3.10	3.20	**	NO	
T1655N-1	3.00	3.10	3.20	3.00	3.10	3.20	**	NO	
T2055-3	3.00	3.10	3.20	3.00	3.10	3.20	**	YES	
T2055-4	3.00	3.10	3.20	3.00	3.10	3.20	**	NO	
T2055-5	3.15	3.25	3.35	3.15	3.25	3.35	0.40	YES	
T2855-3	3.15	3.25	3.35	3.15	3.25	3.35	**	YES	
T2855-4	2.60	2.70	2.80	2.60	2.70	2.80	**	YES	
T2855-5	2.60	2.70	2.80	2.60	2.70	2.80	**	NO	
T2855-6	3.15	3.25	3.35	3.15	3.25	3.35	**	NO	
T2855-7	2.60	2.70	2.80	2.60	2.70	2.80	**	YES	
T2855-8	3.15	3.25	3.35	3.15	3.25	3.35	0.40	YES	
T2855N-1	3.15	3.25	3.35	3.15	3.25	3.35	**	NO	
T3255-3	3.00	3.10	3.20	3.00	3.10	.20	**	YES	
T3255-4	3.00	3.10	3.20	3.00	3.10	.20	**	NO	
T3255-5	3.00	3.10	3.20	3.00	3.10	3.20	**	YES	
T3255N-1	3.00	3.10	3.20	3.00	3.10	3.20	**	NO	
T4055-1	3.20	3.30	3.40	3.20	3.30	3.40	**	YES	

**SEE COMMON DIMENSIONS TABLE

NOTES:

- DIMENSIONING & TOLERANCING CONFORM TO ASME Y14.5M-1994.
- ALL DIMENSIONS ARE IN MILLIMETERS. ANGLES ARE IN DEGREES.
- N IS THE TOTAL NUMBER OF TERMINALS.
- THE TERMINAL #1 IDENTIFIER AND TERMINAL NUMBERING CONVENTION SHALL CONFORM TO JESD 95-1 SPP-012. DETAILS OF TERMINAL #1 IDENTIFIER ARE OPTIONAL, BUT MUST BE LOCATED WITHIN THE ZONE INDICATED. THE TERMINAL #1 IDENTIFIER MAY BE EITHER A MOLD OR MARKED FEATURE.
- DIMENSION b APPLIES TO METALLIZED TERMINAL AND IS MEASURED BETWEEN 0.25 mm AND 0.30 mm FROM TERMINAL TIP.
- ND AND NE REFER TO THE NUMBER OF TERMINALS ON EACH D AND E SIDE RESPECTIVELY.
- DEPOPULATION IS POSSIBLE IN A SYMMETRICAL FASHION.
- COPLANARITY APPLIES TO THE EXPOSED HEAT SINK SLUG AS WELL AS THE TERMINALS.
- DRAWING CONFORMS TO JEDEC MO220, EXCEPT EXPOSED PAD DIMENSION FOR T2855-3 AND T2855-6.
- WARPAGE SHALL NOT EXCEED 0.10 mm.
- MARKING IS FOR PACKAGE ORIENTATION REFERENCE ONLY.
- NUMBER OF LEADS SHOWN ARE FOR REFERENCE ONLY.
- LEAD CENTERLINES TO BE AT TRUE POSITION AS DEFINED BY BASIC DIMENSION "e", ±0.05.

-DRAWING NOT TO SCALE-

TITLE: PACKAGE OUTLINE, 16, 20, 28, 32, 40L THIN QFN, 5x5x0.8mm	
APPROVAL	DOCUMENT CONTROL NO. 21-0140
REV.	1 2/2

Maxim cannot assume responsibility for use of any circuitry other than circuitry entirely embodied in a Maxim product. No circuit patent licenses are implied. Maxim reserves the right to change the circuitry and specifications without notice at any time.

Maxim Integrated Products, 120 San Gabriel Drive, Sunnyvale, CA 94086 408-737-7600 11

MAX2335

Part Number Table

Notes:

1. See the [MAX2335 QuickView Data Sheet](#) for further information on this product family or download the [MAX2335 full data sheet](#) (PDF, 236kB).
2. Other options and links for purchasing parts are listed at: <http://www.maxim-ic.com/sales>.
3. [Didn't Find What You Need?](#) Ask our applications engineers. Expert assistance in finding parts, usually within one business day.
4. Part number suffixes: T or T&R = tape and reel; + = RoHS/lead-free; # = RoHS/lead-exempt. More: See [full data sheet](#) or [Part Naming Conventions](#).
5. * Some packages have variations, listed on the drawing. "PkgCode/Variation" tells which variation the product uses.

Part Number	Free Sample	Buy Direct	Package: TYPE PINS SIZE DRAWING CODE/VAR *	Temp	RoHS/Lead-Free? Materials Analysis
MAX2335EGI				-40C to +85C	RoHS/Lead-Free: No
MAX2335ETI			THIN QFN;28 pin;5x5x0.8mm Dwg: 21-0140K (PDF) Use pkgcode/variation: T2855-3*	-40C to +85C	RoHS/Lead-Free: No Materials Analysis
MAX2335ETI-T			THIN QFN;28 pin;5x5x0.8mm Dwg: 21-0140K (PDF) Use pkgcode/variation: T2855-3*	-40C to +85C	RoHS/Lead-Free: No Materials Analysis

MAX2335ETI+

THIN QFN;28 pin;5x5x0.8mm
Dwg: [21-0140K](#) (PDF)
Use pkgcode/variation: T2855+3*

-40C to +85C RoHS/Lead-Free: [Yes](#)
[Materials Analysis](#)

MAX2335ETI+T

THIN QFN;28 pin;5x5x0.8mm
Dwg: [21-0140K](#) (PDF)
Use pkgcode/variation: T2855+3*

-40C to +85C RoHS/Lead-Free: [Yes](#)
[Materials Analysis](#)

[Didn't Find What You Need?](#)

[CONTACT US: SEND US AN EMAIL](#)

Copyright 2007 by Maxim Integrated Products, Dallas Semiconductor • [Legal Notices](#) • [Privacy Policy](#)