

Date	SYM	REVISION RECORD	AUTH	DR.	CK.
02/29/08	B	ADDED PANEL CUT OUT VIEW	T.B.	B.S.	
10/10/14	C	UPDATED TO ROHS 2 COMPLIANT	T.B.	B.S.	
06/27/17	D	UPDATED ALL DIMENTIONS	T.B.	B.S.	

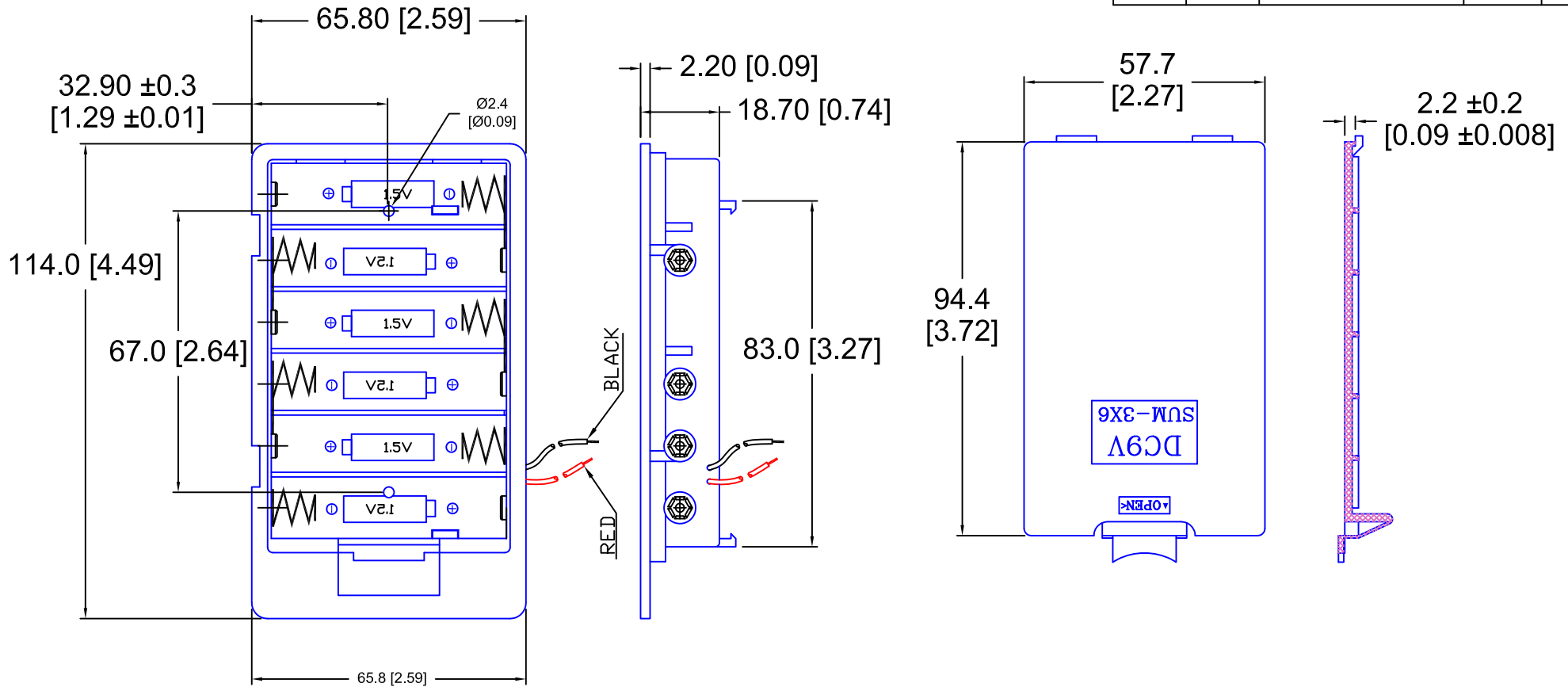

BOTTOM

COVER

SPECIFICATION

- ITEM NO.: SBH361A
- WIRE: UL1007 AWG#26
BLACK & RED 150MM±5MM
STRIP & TIN 5MM±1MM
- MATERIAL: ABS RESIN, BLACK COLOR
- SPRING: 0.7MM 65C SPRING WIRE
- ROHS 2 COMPLIANT

Tolerance (Except as noted)	 Memory Protection Devices, Inc 200 Broad Hollow Road, Farmingdale, New York 11735		
decimal ±.020 (.5)	Scale XX	Drawn By T.S.	Approved By T.B.
Fractional ± .030 (.8)	Title 6 AA PANEL MOUNT BATTERY HOLDER		
Angular ± 3°	Date 06/27/17	Drawing Number SBH361A	