



1060 - 1120 MHz Cavity Band Pass Filter

Part Number: AE1090B11203-NF



ANATECH ELECTRONICS INC
RF & Microwave Filters & Products

Electrical Specifications

Center Frequency: 1090 MHz
Passband: 1060-1120 MHz
1dB Bandwidth: 60 MHz Min
Insertion Loss: 1.2 dB Max @ Fc
Pass band ripple: ± 0.4 dB Max
VSWR: 1.5:1 Max
Rejection1: 50 dBc Min @ 990 MHz
Rejection2: 40 dBc Min @ 1190 MHz
Power Handling: 10 Watts
Impedance: 50 Ohms

Mechanical

Mounting Method: 4mm Thru Hole
Connector Type: N (F)
Dimensions (In): 5.27" x 2.12" x 0.925"
Dimensions (mm): 134 x 54 x 23.5

Environmental

Operating Temperature: -40°C to +70°C
Storage Temperature: -55°C to +95°C
Shock: 20 G. 11ms
Vibration: 20 G 0.5 to 200Hz

Outline Drawing:

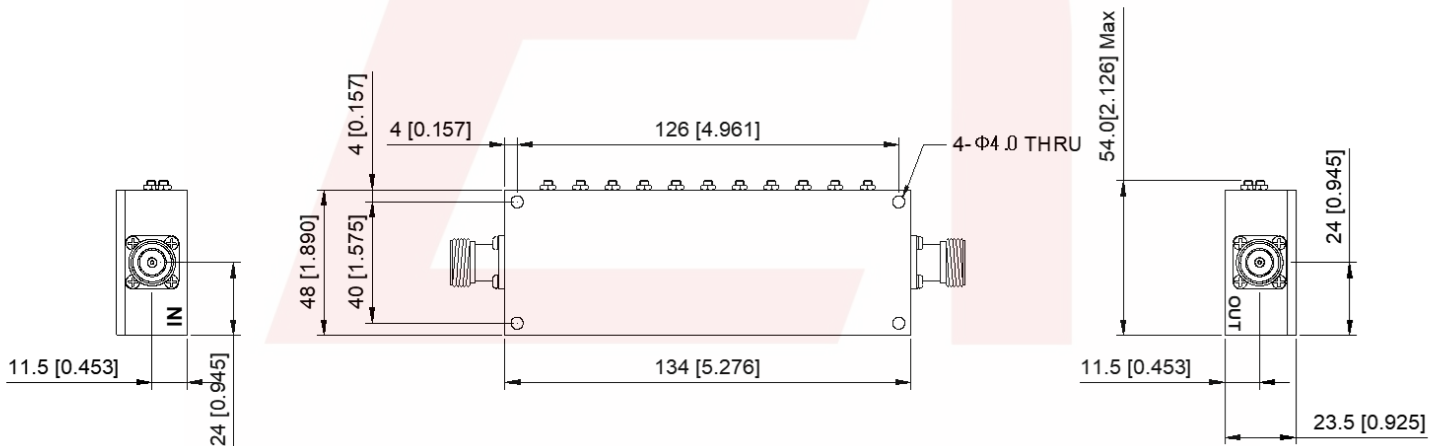

Tolerance: +/-0.01 inches [+/- 0.3mm]

Angles: +/- 1 Deg.

*Tolerance as shown unless otherwise specified in the datasheet electrical specification tables above.

*When max dimensions are called out the above tolerances do not apply as long as it is under the max call out.

DS-B11203-NF-07092020-Rev1

70 Outwater Lane Phone: (973) 772-4242
Garfield, NJ 07026 Fax : (973) 321-3941

Email: sales@anatechelectronics.com
Web: www.anatechelectronics.com



ANATECH ELECTRONICS INC
RF & Microwave Filters & Products

1060 - 1120 MHz Cavity Band Pass Filter

Part Number: AE1090B11203-NF



Response Plot:

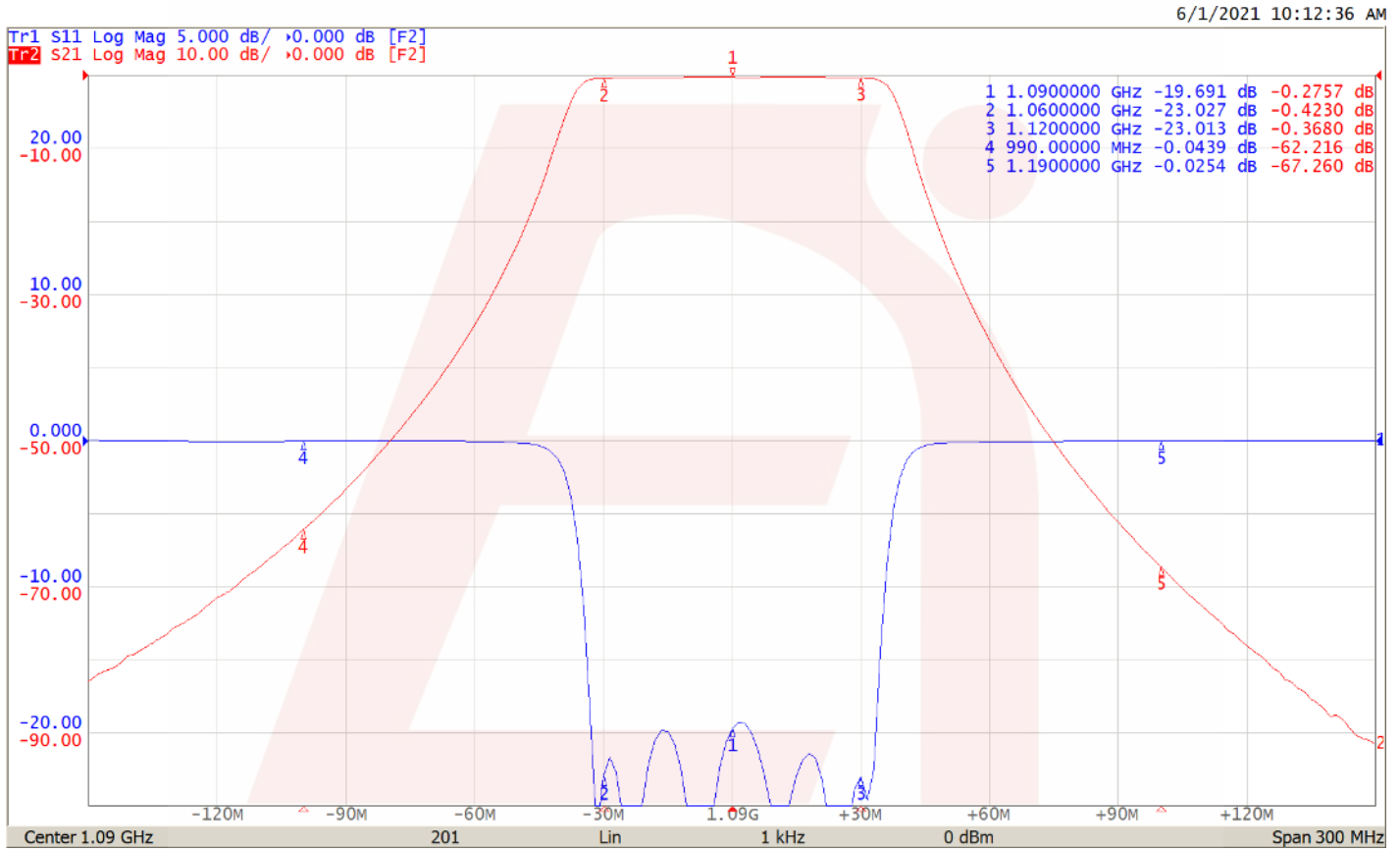

DS-B11203-NF-07092020-Rev1