



**PICDEM™ 2 Plus  
Demonstration Board  
User's Guide**

---

---

**Note the following details of the code protection feature on Microchip devices:**

- Microchip products meet the specification contained in their particular Microchip Data Sheet.
- Microchip believes that its family of products is one of the most secure families of its kind on the market today, when used in the intended manner and under normal conditions.
- There are dishonest and possibly illegal methods used to breach the code protection feature. All of these methods, to our knowledge, require using the Microchip products in a manner outside the operating specifications contained in Microchip's Data Sheets. Most likely, the person doing so is engaged in theft of intellectual property.
- Microchip is willing to work with the customer who is concerned about the integrity of their code.
- Neither Microchip nor any other semiconductor manufacturer can guarantee the security of their code. Code protection does not mean that we are guaranteeing the product as "unbreakable."

Code protection is constantly evolving. We at Microchip are committed to continuously improving the code protection features of our products. Attempts to break Microchip's code protection feature may be a violation of the Digital Millennium Copyright Act. If such acts allow unauthorized access to your software or other copyrighted work, you may have a right to sue for relief under that Act.

---

Information contained in this publication regarding device applications and the like is provided only for your convenience and may be superseded by updates. It is your responsibility to ensure that your application meets with your specifications. MICROCHIP MAKES NO REPRESENTATIONS OR WARRANTIES OF ANY KIND WHETHER EXPRESS OR IMPLIED, WRITTEN OR ORAL, STATUTORY OR OTHERWISE, RELATED TO THE INFORMATION, INCLUDING BUT NOT LIMITED TO ITS CONDITION, QUALITY, PERFORMANCE, MERCHANTABILITY OR FITNESS FOR PURPOSE. Microchip disclaims all liability arising from this information and its use. Use of Microchip devices in life support and/or safety applications is entirely at the buyer's risk, and the buyer agrees to defend, indemnify and hold harmless Microchip from any and all damages, claims, suits, or expenses resulting from such use. No licenses are conveyed, implicitly or otherwise, under any Microchip intellectual property rights.

**Trademarks**

The Microchip name and logo, the Microchip logo, Accuron, dsPIC, KEELOQ, KEELOQ logo, microID, MPLAB, PIC, PICmicro, PICSTART, PRO MATE, rPIC and SmartShunt are registered trademarks of Microchip Technology Incorporated in the U.S.A. and other countries.

AmPLab, FilterLab, Linear Active Thermistor, Migratable Memory, MXDEV, MXLAB, SEEVAL, SmartSensor and The Embedded Control Solutions Company are registered trademarks of Microchip Technology Incorporated in the U.S.A.

Analog-for-the-Digital Age, Application Maestro, CodeGuard, dsPICDEM, dsPICDEM.net, dsPICworks, dsSPEAK, ECAN, ECONOMONITOR, FanSense, FlexROM, fuzzyLAB, In-Circuit Serial Programming, ICSP, ICEPIC, Mindi, MiWi, MPASM, MPLAB Certified logo, MPLIB, MPLINK, PICkit, PICDEM, PICDEM.net, PICLAB, PICtail, PowerCal, PowerInfo, PowerMate, PowerTool, REAL ICE, rLAB, Select Mode, Smart Serial, SmartTel, Total Endurance, UNI/O, WiperLock and ZENA are trademarks of Microchip Technology Incorporated in the U.S.A. and other countries.

SQTP is a service mark of Microchip Technology Incorporated in the U.S.A.

All other trademarks mentioned herein are property of their respective companies.

© 2007, Microchip Technology Incorporated, Printed in the U.S.A., All Rights Reserved.

 Printed on recycled paper.

**QUALITY MANAGEMENT SYSTEM**  
**CERTIFIED BY DNV**  
**== ISO/TS 16949:2002 ==**

*Microchip received ISO/TS-16949:2002 certification for its worldwide headquarters, design and wafer fabrication facilities in Chandler and Tempe, Arizona; Gresham, Oregon and design centers in California and India. The Company's quality system processes and procedures are for its PIC® MCUs and dsPIC® DSCs, KEELOQ® code hopping devices, Serial EEPROMs, microperipherals, nonvolatile memory and analog products. In addition, Microchip's quality system for the design and manufacture of development systems is ISO 9001:2000 certified.*

---



---

**Table of Contents**

---



---

<b>Preface .....</b>	<b>1</b>
<b>Chapter 1. Introduction</b>	
1.1 Introduction .....	7
1.2 Development Kit Contents .....	7
1.3 PICDEM™ 2 Plus Demonstration Board .....	8
1.4 Sample Devices .....	9
1.5 Sample Programs .....	9
<b>Chapter 2. Getting Started</b>	
2.1 PICDEM™ 2 Plus as a Stand-Alone Board – Preprogrammed Device .....	11
2.2 PICDEM™ 2 Plus Used with an In-Circuit Emulator or In-Circuit Debugger .....	12
<b>Chapter 3. Tutorial</b>	
3.1 Tutorial Program Operation .....	13
3.2 Source Code and Application Notes .....	16
<b>Appendix A. Hardware Detail</b>	
A.1 Processor Sockets .....	17
A.2 Display .....	17
A.3 Power Supply .....	17
A.4 RS-232 Serial Port .....	17
A.5 Switches .....	18
A.6 Oscillator Options .....	18
A.7 Analog Input .....	18
A.8 ICD Connector .....	18
A.9 Temperature Sensor .....	18
A.10 Serial EEPROM .....	18
A.11 LCD .....	18
A.12 Sample Devices .....	19
A.13 Board Layout and Schematics .....	20
<b>Index.....</b>	<b>23</b>
<b>Worldwide Sales and Service .....</b>	<b>24</b>

# PICDEM™ 2 Plus User's Guide

---

NOTES:

---

---

## Preface

---

---

### NOTICE TO CUSTOMERS

All documentation becomes dated, and this manual is no exception. Microchip tools and documentation are constantly evolving to meet customer needs, so some actual dialogs and/or tool descriptions may differ from those in this document. Please refer to our web site ([www.microchip.com](http://www.microchip.com)) to obtain the latest documentation available.

Documents are identified with a “DS” number. This number is located on the bottom of each page, in front of the page number. The numbering convention for the DS number is “DSXXXXA”, where “XXXX” is the document number and “A” is the revision level of the document.

For the most up-to-date information on development tools, see the MPLAB® IDE on-line help. Select the Help menu, and then Topics to open a list of available on-line help files.

## INTRODUCTION

This chapter contains general information that will be useful to know before using the PICDEM™ 2 Plus demonstration board. Items discussed in this chapter include:

- Document Layout
- Conventions Used in this Guide
- Warranty Registration
- Recommended Reading
- The Microchip Web Site
- Development Systems Customer Change Notification Service
- Customer Support
- Document Revision History

## DOCUMENT LAYOUT

This document describes the PICDEM 2 Plus demonstration board, tutorial and demonstration software. The guide's contents include:

- **Chapter 1. “Introduction”** – Introduces the PICDEM 2 Plus and provides a brief description of the hardware.
- **Chapter 2. “Getting Started”** – Goes through a basic step-by-step process for getting your PICDEM 2 Plus up and running as a stand-alone board or with an ICE or ICD.
- **Chapter 3. “Tutorial”** – Provides a detailed description of the tutorial program.
- **Appendix A. “Hardware Detail”** – Describes in detail the hardware of the PICDEM 2 Plus demonstration board.

# PICDEM™ 2 Plus User's Guide

## CONVENTIONS USED IN THIS GUIDE

This manual uses the following documentation conventions:

### DOCUMENTATION CONVENTIONS

Description	Represents	Examples
<b>Arial font:</b>		
Italic characters	Referenced books	<i>MPLAB® IDE User's Guide</i>
	Emphasized text	...is the <i>only</i> compiler...
Initial caps	A window	the Output window
	A dialog	the Settings dialog
	A menu selection	select Enable Programmer
Quotes	A field name in a window or dialog	"Save project before build"
Underlined, italic text with right angle bracket	A menu path	<u>File&gt;Save</u>
Bold characters	A dialog button	Click <b>OK</b>
	A tab	Click the <b>Power</b> tab
N'Rnnnn	A number in verilog format, where N is the total number of digits, R is the radix and n is a digit.	4'b0010, 2'hF1
Text in angle brackets < >	A key on the keyboard	Press <Enter>, <F1>
<b>Courier New font:</b>		
Plain Courier New	Sample source code	#define START
	Filenames	autoexec.bat
	File paths	c:\mcc18\h
	Keywords	_asm, _endasm, static
	Command-line options	-Opa+, -Opa-
	Bit values	0, 1
	Constants	0xFF, 'A'
Italic Courier New	A variable argument	<i>file.o</i> , where <i>file</i> can be any valid filename
Square brackets [ ]	Optional arguments	mcc18 [options] <i>file</i> [options]
Curly brackets and pipe character: {   }	Choice of mutually exclusive arguments; an OR selection	errorlevel {0 1}
Ellipses...	Replaces repeated text	var_name [, var_name...]
	Represents code supplied by user	void main (void) { ... }

---

---

## WARRANTY REGISTRATION

Please complete the enclosed Warranty Registration Card and mail it promptly. Sending in the Warranty Registration Card entitles users to receive new product updates. Interim software releases are available at the Microchip web site.

## RECOMMENDED READING

This user's guide describes how to use the PICDEM 2 Plus demonstration board. The following Microchip documents are available and recommended as supplemental reference resources.

### Readme Files

- Readme for the PICDEM™ 2 Plus – An ASCII text file in the Readmes subdirectory of the MPLAB® IDE installation directory
- Other Readme Files – For other tools, see the tool-specific Readme file in the same Readmes subdirectory of the MPLAB IDE installation directory

### Reference Documents

Reference documents may be obtained by contacting your nearest Microchip sales office (listed in the back of this document) or by downloading via the Microchip web site ([www.microchip.com](http://www.microchip.com)). Recommended documents include:

- Individual data sheets and reference manuals:
  - *PIC16F87X Data Sheet* (DS30292)
  - *PIC18FXX2 Data Sheet* (DS39564)
  - *PICmicro® Mid-Range MCU Family Reference Manual* (DS33023)
  - *PICmicro® 18C MCU Family Reference Manual* (DS39500)
  - *TC74 Data Sheet* (DS21462)
- *MPLAB® IDE Simulator, Editor User's Guide* (DS51025)
- *MPASM™ Assembler, MPLINK™ Object Linker, MPLIB™ Object Librarian User's Guide* (DS33014)
- *PRO MATE® II User's Guide* (DS30082)
- *MPLAB® IDE PICSTART® Plus User's Guide* (DS51028)
- *MPLAB® ICE Emulator User's Guide* (DS51159)
- *MPLAB® ICD 2 In-Circuit Debugger Quick Start Guide* (DS51268)

# PICDEM™ 2 Plus User's Guide

---

## THE MICROCHIP WEB SITE

Microchip provides online support via our web site at [www.microchip.com](http://www.microchip.com). This web site is used as a means to make files and information easily available to customers. Accessible by using your favorite Internet browser, the web site contains the following information:

- **Product Support** – Data sheets and errata, application notes and sample programs, design resources, user's guides and hardware support documents, latest software releases and archived software
- **General Technical Support** – Frequently Asked Questions (FAQs), technical support requests, online discussion groups, Microchip consultant program member listing
- **Business of Microchip** – Product selector and ordering guides, latest Microchip press releases, listing of seminars and events, listings of Microchip sales offices, distributors and factory representatives

## DEVELOPMENT SYSTEMS CUSTOMER CHANGE NOTIFICATION SERVICE

Microchip's customer notification service helps keep customers current on Microchip products. Subscribers will receive e-mail notification whenever there are changes, updates, revisions or errata related to a specified product family or development tool of interest.

To register, access the Microchip web site at [www.microchip.com](http://www.microchip.com), click on Customer Change Notification and follow the registration instructions.

The Development Systems product group categories are:

- **Compilers** – The latest information on Microchip C compilers and other language tools. These include the MPLAB C18 and MPLAB C30 C compilers; MPASM™ and MPLAB ASM30 assemblers; MPLINK™ and MPLAB LINK30 object linkers; and MPLIB™ and MPLAB LIB30 object librarians.
- **Emulators** – The latest information on Microchip in-circuit emulators. This includes the MPLAB ICE 2000 and MPLAB ICE 4000.
- **In-Circuit Debuggers** – The latest information on the Microchip in-circuit debugger, MPLAB ICD 2.
- **MPLAB® IDE** – The latest information on Microchip MPLAB IDE, the Windows® Integrated Development Environment for development systems tools. This list is focused on the MPLAB IDE, MPLAB SIM simulator, MPLAB IDE Project Manager and general editing and debugging features.
- **Programmers** – The latest information on Microchip programmers. These include the MPLAB PM3 and PRO MATE® II device programmers and the PICSTART® Plus and PICkit™ 1 development programmers.



---

---

## CUSTOMER SUPPORT

Users of Microchip products can receive assistance through several channels:

- Distributor or Representative
- Local Sales Office
- Field Application Engineer (FAE)
- Technical Support

Customers should contact their distributor, representative or field application engineer (FAE) for support. Local sales offices are also available to help customers. A listing of sales offices and locations is included in the back of this document.

Technical support is available through the web site at: <http://support.microchip.com>.

## DOCUMENT REVISION HISTORY

### **Revision D (August 2007)**

- Updated document to new format, including the addition of a preface.
- Corrected schematic in Figure A-2 and updated Figure A-3.

### **Revision C (November 2006)**

### **Revision B (February 2004)**

# PICDEM™ 2 Plus User's Guide

---

NOTES:

---

---

## Chapter 1. Introduction

---

---

### 1.1 INTRODUCTION

Thank you for purchasing the PICDEM™ 2 Plus demonstration board from Microchip Technology Incorporated. The PICDEM 2 Plus is a simple board that demonstrates the capabilities of the 18, 28 and 40-pin PIC16 and PIC18 devices.

The PICDEM 2 Plus can be used stand-alone with a programmed part, with an in-circuit emulator (for example, MPLAB® ICE) or with an in-circuit debugger (such as MPLAB ICD 2). Sample programs are provided to demonstrate the unique features of the supported devices.

### 1.2 DEVELOPMENT KIT CONTENTS

The PICDEM 2 Plus kit comes with the following:

- PICDEM 2 Plus demonstration board (Figure 1-1)
- Sample devices
- CD-ROM that contains:
  - Sample programs
  - PICDEM™ 2 Plus User's Guide
  - Application Notes

If you are missing any part of the kit, please contact your nearest Microchip sales office listed in the back of this publication for help.

## 1.3 PICDEM™ 2 PLUS DEMONSTRATION BOARD

The PICDEM 2 Plus demonstration board has the following hardware features:

- 18, 28 and 40-pin DIP sockets  
(although three sockets are provided, only one device may be used at a time)
- On-board, +5V regulator for direct input from 9V, 100 mA AC/DC wall adapter or 9V battery, or hooks for a +5V, 100 mA regulated DC supply
- RS-232 socket and associated hardware for direct connection to an RS-232 interface
- In-Circuit Debugger (ICD) connector
- 5 k $\Omega$  pot for devices with analog inputs
- Three pushbutton switches for external stimulus and Reset
- Green power-on indicator LED
- Four red LEDs connected to PORTB
- Jumper J6 to disconnect LEDs from PORTB
- 4 MHz, canned crystal oscillator
- Unpopulated holes provided for crystal connection
- 32.768 kHz crystal for Timer1 clock operation
- Jumper J7 to disconnect on-board RC oscillator (approximately 2 MHz)
- 32K x 8 Serial EEPROM
- LCD display
- Piezo buzzer
- Prototype area for user hardware
- Microchip TC74 thermal sensor

**FIGURE 1-1: PICDEM™ 2 PLUS HARDWARE**

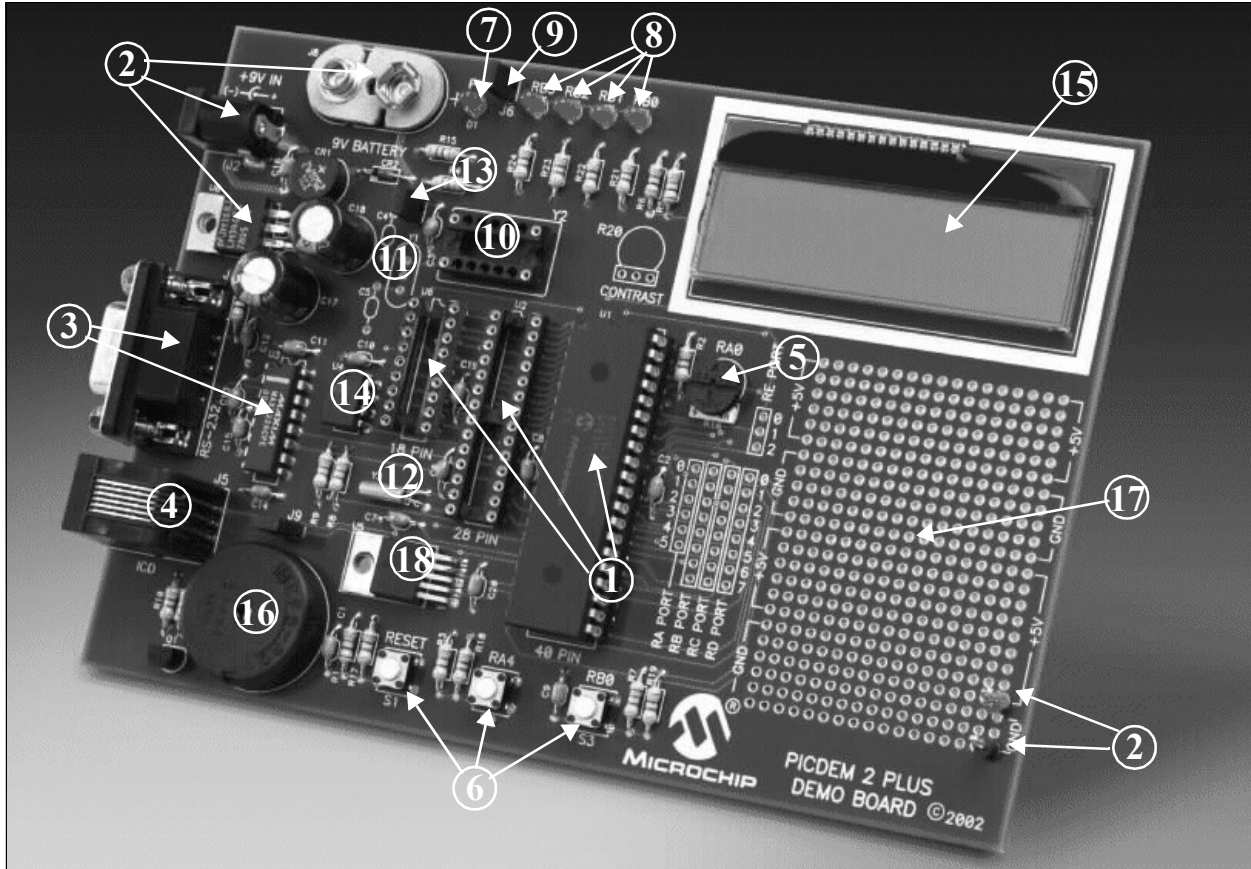

## 1.4 SAMPLE DEVICES

Two Flash devices are included. The device types may change, but will generally include PIC16 and PIC18 40-pin, DIP devices.

## 1.5 SAMPLE PROGRAMS

The PICDEM 2 Plus kit includes a CD-ROM with sample demonstration programs. These programs may be used with the included sample devices, with an In-Circuit Emulator (ICE) or with an In-Circuit Debugger (ICD). For each type of device (PIC16 or PIC18), demo source code (several ASM files) and compiled code (one Hex file) are provided.

# PICDEM™ 2 Plus User's Guide

---

NOTES:

---

---

## Chapter 2. Getting Started

---

---

The PICDEM 2 Plus may be used as a stand-alone board with a preprogrammed device, with an In-Circuit Emulator (ICE) or with an In-Circuit Debugger (ICD). For a list of PIC® microcontroller compatible ICEs or ICDs, see the *Development Systems Ordering Guide*.

### 2.1 PICDEM™ 2 PLUS AS A STAND-ALONE BOARD – PREPROGRAMMED DEVICE

The PICDEM 2 Plus may be demonstrated immediately by following the steps listed below:

- Place the preprogrammed sample device in the appropriate socket on the PICDEM 2 Plus demonstration board.
- Place a jumper on J6 (to enable the LEDs).
- Verify that the board is set up for a 4 MHz, canned oscillator (that is, no jumper on J7; a 4 MHz oscillator in Y2 and nothing in Y1, C4 and C5).
- Apply power to the PICDEM 2 Plus. For information on acceptable power sources, see Appendix A.

To reprogram the sample device, the following will be necessary:

- Program source code – user source code may be used to program the device, or if this previously has been done, the sample program may be restored from the file on the included CD-ROM.
- An assembler, such as MPASM™ assembler (available with MPLAB® IDE), or a compiler, such as MPLAB C18 (PIC18 devices only)

Source code must be assembled or compiled into a hex file before it can be programmed into the device. Microchip Technology's MPASM assembler or MPLAB C18 C compiler may be used. Both are compatible with MPLAB IDE.

Other assemblers/compilers may be used. For a list of these PIC MCU compatible language tools, see the Microchip web site ([www.microcip.com](http://www.microcip.com)).

A device programmer, such as PRO MATE® II, MPLAB® PM3, PICSTART® Plus or MPLAB ICD 2 (programmer functionality available with MPLAB IDE v6.00 or greater)

Once the sample program is in hex file format, a programmer can program a Flash device. Microchip Technology's PRO MATE II device programmer, PICSTART Plus development programmer or MPLAB ICD 2 may be used. All are compatible with MPLAB IDE.

Other programmers may be used. For a list of these PICmicro MCU compatible programmers, see the Microchip web site ([www.microcip.com](http://www.microcip.com)).

If the code protection bit(s) have not been programmed, the on-chip program memory can be read out for verification purposes.

# PICDEM™ 2 Plus User's Guide

## 2.2 PICDEM™ 2 PLUS USED WITH AN IN-CIRCUIT EMULATOR OR IN-CIRCUIT DEBUGGER

To use PICDEM 2 Plus with an In-Circuit Emulator (ICE) or In-Circuit Debugger (ICD), refer to the tool's user guide for instructions to learn how to:

- Power-up and configure the ICE/ICD
- Connect to target boards (such as in Figure 2-1)

**FIGURE 2-1: PICDEM™ 2 PLUS CONNECTED TO MPLAB® ICD 2 USING USB**

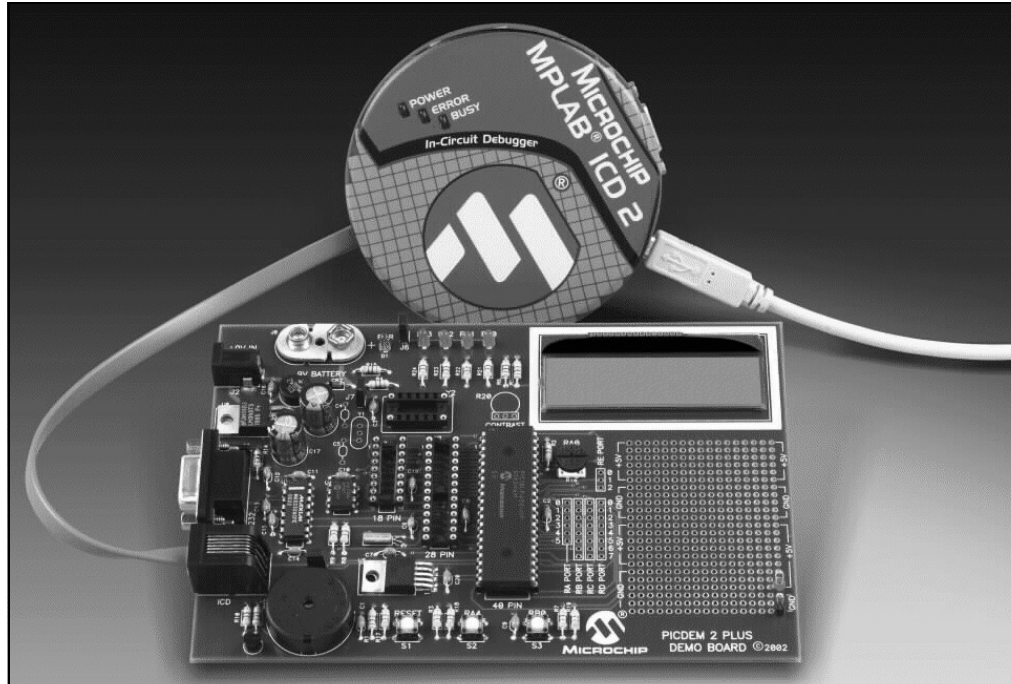

Configure the PICDEM 2 Plus for the desired oscillator as described in Table 2-1. Refer to the ICE/ICD user's guide for any oscillator configuration requirements.

**TABLE 2-1: OSCILLATOR SELECTION**

Oscillator Selection on PICDEM™ 2 Plus	Modification on PICDEM 2 Plus
RC	J7 installed, Y2 empty, Y1 empty
Crystal	J7 removed, Y2 empty, crystal in Y1, caps in C4 and C5
Canned Oscillator	J7 removed, oscillator in Y2 (Y1, C4, C5 empty)
Resonator – no internal caps	J7 removed, Y2 empty, resonator in Y1, caps in C4 and C5
Resonator – with internal caps	J7 removed, Y2 empty, resonator in Y1, C4 and C5 empty



---

---

## Chapter 3. Tutorial

---

---

The tutorial program is preprogrammed into the sample device. (For example, the file `p16demo.hex` is for a PIC16 device and `p18demo.hex` is for a PIC18 device.) This program also is on the included CD-ROM program disk for user reference. (If the sample device has been reprogrammed with another program, the tutorial may be reprogrammed into the device.)

For a flowchart of the tutorial program, see Figure 3-1.

For detailed information on the PICDEM 2 Plus hardware, please refer to Appendix A.

### 3.1 TUTORIAL PROGRAM OPERATION

The tutorial program is made up of four components, which are individually displayed on the LCD.

#### 1. Voltmeter

This mode uses the A/D module to measure the voltage of the R16 pot and display a voltage between 0.00V and 5.00V on the LCD.

Voltage is continually updated until the mode is exited by pressing RB0.

#### 2. Buzzer

This mode turns on the Piezo buzzer, using the CCP1 module I/O pin, RC2.

The period and duty cycle of the CCP1 frequency can be changed while the buzzer is on. The changes in period and duty cycle are recognized immediately in the buzzer tone.

- To change the period and/or the duty cycle, press RB0 under the "Buzzer" menu.

The buzzer will then sound off with the default setting of 80h for the period and duty cycle. The cursor will flash over the period's first digit, indicating that the PR2 register is ready to be incremented.

- To change the duty cycle, press RA4 once and the cursor will now flash over the duty cycle's first digit, indicating it is now ready to increment the CCPR1L register.

The next press of RA4 will exit the buzzer function.

#### 3. Temperature

This mode uses a TC74 thermal sensor to measure ambient temperature in Celsius and then display that temperature on the LCD. Communication between the PIC® MCU and sensor is accomplished using the MSSP module. This mode is exited by pressing RB0. This mode contains code that will write to the external on-board EEPROM. Every two seconds, the code will write to a defined EEPROM address and store the current temperature in that address.

## 4. Clock

Once this mode is entered from the main menu, a Real-Time Clock will start counting from 00:00:00.

The Timer1 module and a 32 kHz clock crystal are used to establish a Real-Time Clock.

By pressing RA4, the clock time can be set to the user's preference. When RA4 is pressed to set the time, the cursor will flash over the hours' ten digit. Press RA4 again and the cursor will now flash over the minutes' ten digit.

RB0 is used to increment hours and minutes whenever the cursor is flashing over either. After the minutes have been set, press RA4 and the time will be set and the LCD is returned to an active clock display.

The data that is sent to the LCD is also sent to the RS-232 serial port using the USART on the PIC MCU. A HyperTerminal™ program on the PC will be able to display the same information that is displayed on the LCD

FIGURE 3-1: TUTORIAL PROGRAM FLOWCHART

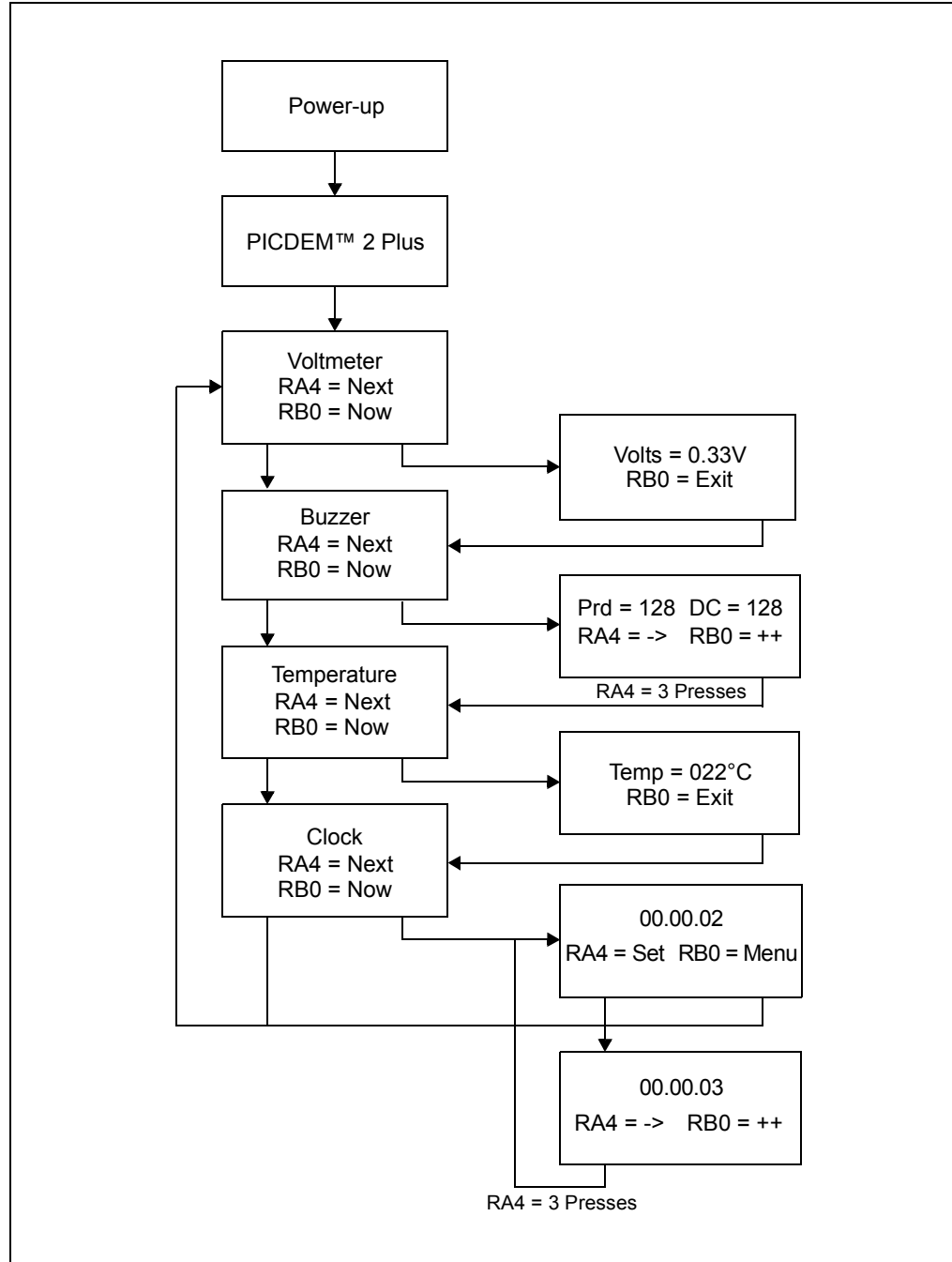

## 3.2 SOURCE CODE AND APPLICATION NOTES

In addition to the assembled tutorial program (hex files), source code used to create these hex files is included on the PICDEM 2 Plus CD-ROM. Both source code and related hex files are found in device-specific directories.

Application notes with additional use examples are included on the CD-ROM.

For information on how to reprogram the device with new or modified code, or how to restore the tutorial program, please see **Section 2.1 “PICDEM™ 2 Plus as a Stand-Alone Board – Preprogrammed Device”**.

---

---

## Appendix A. Hardware Detail

---

---

The PICDEM 2 Plus hardware is extremely simple and illustrates the ease of use of various PIC MCUs. This section describes the PICDEM 2 Plus hardware elements.

### A.1 PROCESSOR SOCKETS

Although three sockets are provided, only one device may be used at a time.

- 18-pin socket
- 28-pin socket
- 40-pin socket

### A.2 DISPLAY

- Four red LEDs are connected to PORTB of each processor type. The PORTB pins are set high to light the LEDs. These LEDs may be disconnected from PORTB by removing jumper J6.
- One green LED is provided to indicate whether there is power to the PICDEM 2 Plus demonstration board.  
LED On = Powered. LED Off = Not Powered.

### A.3 POWER SUPPLY

There are three ways to supply power to the PICDEM 2 Plus:

- A 9V battery can be plugged into J8.
- A 9V, 100 mA unregulated AC or DC supply can be plugged into J2. A power supply can be purchased through Microchip, part #AC162039.
- A +5V, 100 mA regulated DC supply can be connected to the hooks provided.

**Note:** The PICDEM 2 Plus kit does not include a power supply.

MPLAB ICE 2000 users have a regulated +5V power supply available in the logic probe connector and can easily connect to the hooks on PICDEM 2 Plus. (Red probe to +5V and Black probe to GND.)

MPLAB ICD 2 users may use the ICD to power the target board to 5V, up to 200 mA, if the MPLAB ICD 2 is connected to the PC with a serial cable.

### A.4 RS-232 SERIAL PORT

An RS-232, level-shifting IC has been provided with all the necessary hardware to support connection of an RS-232 host through the DB9 connector. The port is configured as DCE and can be connected to a PC using a straight-through cable.

The PIC16/PIC18 RX and TX pins are tied to the RX and TX lines of the MAX232A.

# PICDEM™ 2 Plus User's Guide

---

## A.5 SWITCHES

Three switches provide the following functions:

- S1 –  $\overline{\text{MCLR}}$  to hard reset the processor
- S2 – Active-low switch connected to RA4
- S3 – Active-low switch connected to RB0

Switches, S1 and S3, have debounce capacitors, whereas S2 does not, allowing the user to investigate debounce techniques.

When pressed, the switches are grounded. When Idle, they are pulled high (+5V).

## A.6 OSCILLATOR OPTIONS

- RC oscillator (2 MHz approximately) supplied. This oscillator may be disabled by removing jumper J7.
- Pads provided for user-furnished crystal and two capacitors.
- Removable, 4 MHz, canned oscillator.
- 32.768 kHz (watch-type) crystal for Timer1.

## A.7 ANALOG INPUT

A 5 k $\Omega$  potentiometer is connected through a series 470 $\Omega$  resistor to AN0.

The pot can be adjusted from V<sub>DD</sub> to GND to provide an analog input to the parts with an A/D module.

## A.8 ICD CONNECTOR

By way of the modular connector (J5), the MPLAB ICD 2 can be connected for low-cost debugging. The ICD connector utilizes RB6 and RB7 of the microcontroller for in-circuit debugging.

## A.9 TEMPERATURE SENSOR

This is a serial digital thermal sensor (TC74) connected to the 28 and 40-pin microcontrollers via RC3 and RC4.

Communication is accomplished with the TC74 via its 2-wire I<sup>2</sup>C™ compatible serial port. This device has an address of `\b1001101`.

## A.10 SERIAL EEPROM

A 24L256 256K (32K x 8) serial EEPROM is included on the board to illustrate I<sup>2</sup>C bus concepts.

## A.11 LCD

An LCD display with two lines, 16 characters each, is connected to the 28 and 40-pin sockets. There are three control lines (RA3:RA1) and four data lines (RD3:RD0).

A 5 k $\Omega$  pot may be installed into R20 to adjust contrast on the LCD. If this is done, R5 and R6 need to be removed.

## A.12 SAMPLE DEVICES

A sample part programmed with a simple program is included in the PICDEM 2 Plus kit.

Table A-1 lists the I/O features and port connections for each processor type.

**TABLE A-1: PORT CONNECTIONS**

Device	LEDs	RS-232	S1	S2	S3	Pot R16	LCD	EEPROM	Buzzer	ICD	Temp Sensor	Y1/Y2
18-pin	RB3:RB0	N/A	$\overline{\text{MCLR}}$	RA4	RB0	RA0	N/A	N/A	N/A	RB6/RB7	N/A	Yes
28-pin	RB3:RB0	RC6/RC7	$\overline{\text{MCLR}}$	RA4	RB0	RA0	RA3:RA1	RC3/RC4	RC2	RB6/RB7	RC3/RC4	Yes
40-pin	RB3:RB0	RC6/RC7	$\overline{\text{MCLR}}$	RA4	RB0	RA0	RA3:RA1 RD3:RD0	RC3/RC4	RC2	RB6/RB7	RC3/RC4	Yes

# PICDEM™ 2 Plus User's Guide

## A.13 BOARD LAYOUT AND SCHEMATICS

The following figures show the parts layout (silkscreen) and schematics for the PICDEM 2 Plus demonstration board.

**FIGURE A-1: PICDEM™ 2 PLUS PARTS LAYOUT**

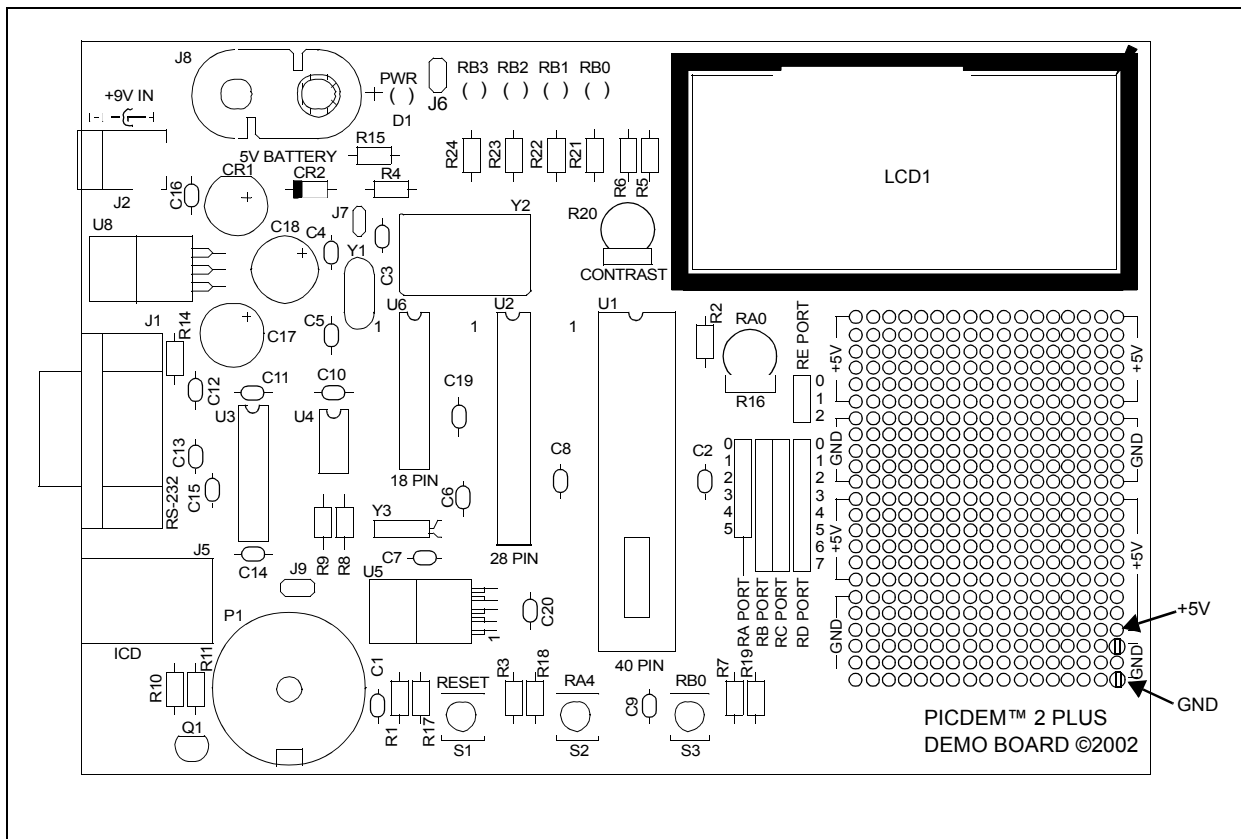



**FIGURE A-2: PICDEM™ 2 PLUS SCHEMATIC**

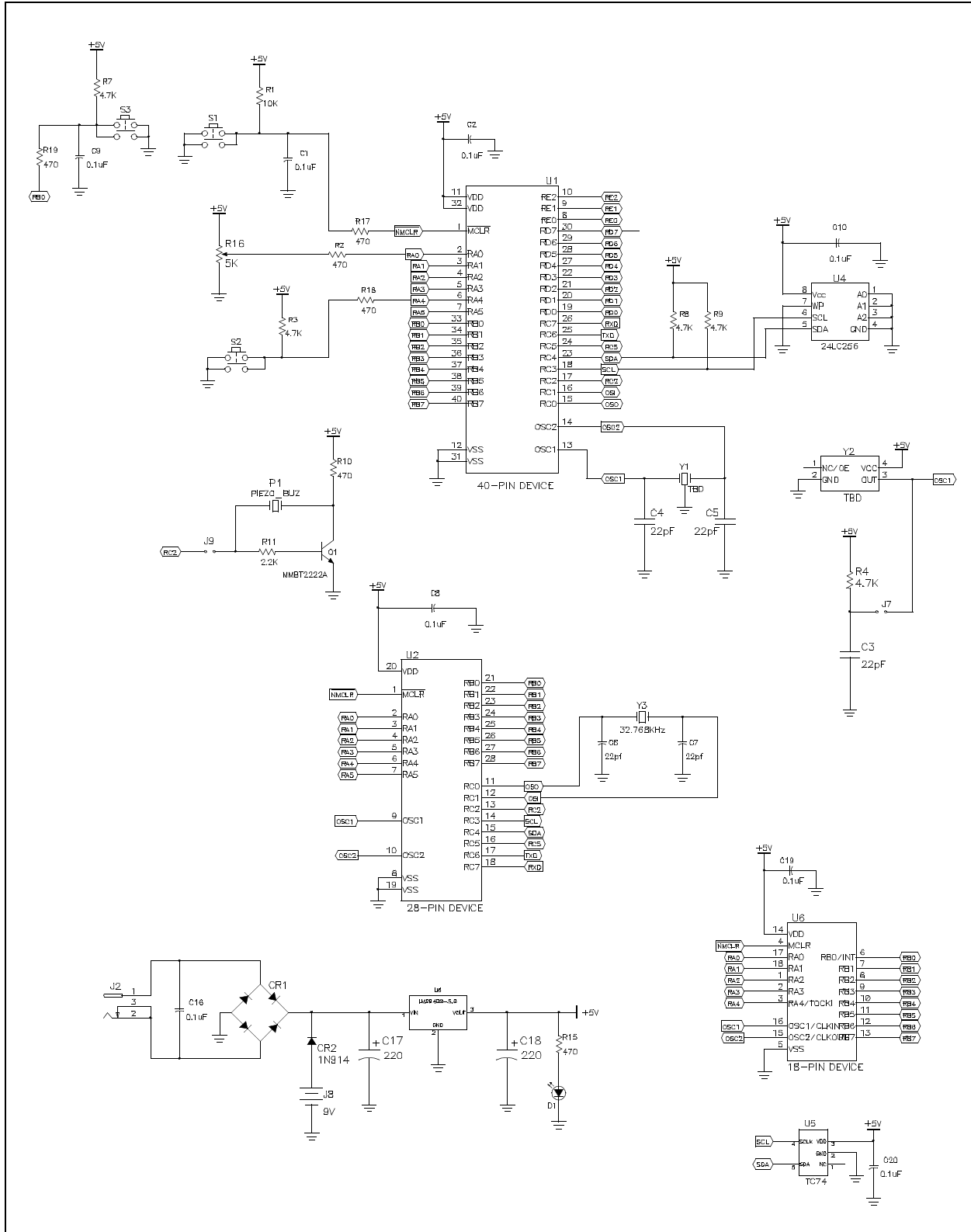



**Index**

<b>A</b>		<b>O</b>	
A/D Input .....	8, 18	Oscillator Options .....	18
<b>B</b>		Oscillator Selection .....	12
Buzzer .....	13	<b>P</b>	
Buzzer, Piezo .....	8	PIC16 .....	7
<b>C</b>		Tutorial Program .....	13
Clock .....	14	PIC18 .....	7
Customer Notification Service .....	4	Tutorial Program .....	13
Customer Support .....	5	PICDEM 2 Plus Kit. <i>See</i> Kit Components.	
<b>D</b>		PICSTART® Plus .....	11
Demonstration Board .....	8, 11, 17	Piezo Buzzer .....	8
Parts Layout .....	20	PRO MATE® II .....	11
Power Supply .....	11, 17	Pushbuttons. <i>See</i> Switches.	
Schematics .....	20	<b>R</b>	
Silkscreen .....	20	Reading, Recommended .....	3
Demonstration Programs. <i>See</i> Sample Programs.		Readme .....	3
Documentation		Reference Documents .....	3
Conventions .....	2	Revision History .....	5
Layout .....	1	RS-232 .....	8, 17
<b>E</b>		<b>S</b>	
EEPROM, Serial .....	8, 18	Sample Devices .....	7, 9, 19
<b>H</b>		Sample Programs .....	7, 9
Hardware .....	17	Sockets .....	17
<b>I</b>		Switches .....	8, 18
ICD Connector .....	18	<b>T</b>	
Internet Address .....	4	TC74 .....	8
<b>K</b>		Temperature .....	13
Kit Components .....	7	Temperature Sensor .....	18
<b>L</b>		TC74 .....	18
LCD .....	8, 18	Tutorial .....	13
LEDs		Tutorial Program	
Green Display .....	8, 17	Flowchart .....	15
Red Display .....	8, 11, 17	Source Code, Application Notes .....	16
<b>M</b>		<b>V</b>	
Microchip Internet Web Site .....	4	Voltmeter .....	13
MPASM Assembler .....	11	<b>W</b>	
MPLAB C18 C Compiler .....	11	Warranty Registration .....	3
MPLAB ICD 2 .....	7, 11, 12, 17, 18	WWW Address .....	4
MPLAB ICE .....	7, 12		
MPLAB ICE 2000 .....	17		
MPLAB IDE .....	11		



---

---

## WORLDWIDE SALES AND SERVICE

---

---

### AMERICAS

**Corporate Office**  
2355 West Chandler Blvd.  
Chandler, AZ 85224-6199  
Tel: 480-792-7200  
Fax: 480-792-7277  
Technical Support:  
<http://support.microchip.com>  
Web Address:  
[www.microchip.com](http://www.microchip.com)

#### Atlanta

Duluth, GA  
Tel: 678-957-9614  
Fax: 678-957-1455

#### Boston

Westborough, MA  
Tel: 774-760-0087  
Fax: 774-760-0088

#### Chicago

Itasca, IL  
Tel: 630-285-0071  
Fax: 630-285-0075

#### Dallas

Addison, TX  
Tel: 972-818-7423  
Fax: 972-818-2924

#### Detroit

Farmington Hills, MI  
Tel: 248-538-2250  
Fax: 248-538-2260

#### Kokomo

Kokomo, IN  
Tel: 765-864-8360  
Fax: 765-864-8387

#### Los Angeles

Mission Viejo, CA  
Tel: 949-462-9523  
Fax: 949-462-9608

#### Santa Clara

Santa Clara, CA  
Tel: 408-961-6444  
Fax: 408-961-6445

#### Toronto

Mississauga, Ontario,  
Canada  
Tel: 905-673-0699  
Fax: 905-673-6509

### ASIA/PACIFIC

**Asia Pacific Office**  
Suites 3707-14, 37th Floor  
Tower 6, The Gateway  
Harbour City, Kowloon  
Hong Kong  
Tel: 852-2401-1200  
Fax: 852-2401-3431

**Australia - Sydney**  
Tel: 61-2-9868-6733  
Fax: 61-2-9868-6755

**China - Beijing**  
Tel: 86-10-8528-2100  
Fax: 86-10-8528-2104

**China - Chengdu**  
Tel: 86-28-8665-5511  
Fax: 86-28-8665-7889

**China - Fuzhou**  
Tel: 86-591-8750-3506  
Fax: 86-591-8750-3521

**China - Hong Kong SAR**  
Tel: 852-2401-1200  
Fax: 852-2401-3431

**China - Qingdao**  
Tel: 86-532-8502-7355  
Fax: 86-532-8502-7205

**China - Shanghai**  
Tel: 86-21-5407-5533  
Fax: 86-21-5407-5066

**China - Shenyang**  
Tel: 86-24-2334-2829  
Fax: 86-24-2334-2393

**China - Shenzhen**  
Tel: 86-755-8203-2660  
Fax: 86-755-8203-1760

**China - Shunde**  
Tel: 86-757-2839-5507  
Fax: 86-757-2839-5571

**China - Wuhan**  
Tel: 86-27-5980-5300  
Fax: 86-27-5980-5118

**China - Xian**  
Tel: 86-29-8833-7252  
Fax: 86-29-8833-7256

### ASIA/PACIFIC

**India - Bangalore**  
Tel: 91-80-4182-8400  
Fax: 91-80-4182-8422

**India - New Delhi**  
Tel: 91-11-4160-8631  
Fax: 91-11-4160-8632

**India - Pune**  
Tel: 91-20-2566-1512  
Fax: 91-20-2566-1513

**Japan - Yokohama**  
Tel: 81-45-471- 6166  
Fax: 81-45-471-6122

**Korea - Daegu**  
Tel: 82-53-744-4301  
Fax: 82-53-744-4302

**Korea - Seoul**  
Tel: 82-2-554-7200  
Fax: 82-2-558-5932 or  
82-2-558-5934

**Malaysia - Penang**  
Tel: 60-4-646-8870  
Fax: 60-4-646-5086

**Philippines - Manila**  
Tel: 63-2-634-9065  
Fax: 63-2-634-9069

**Singapore**  
Tel: 65-6334-8870  
Fax: 65-6334-8850

**Taiwan - Hsin Chu**  
Tel: 886-3-572-9526  
Fax: 886-3-572-6459

**Taiwan - Kaohsiung**  
Tel: 886-7-536-4818  
Fax: 886-7-536-4803

**Taiwan - Taipei**  
Tel: 886-2-2500-6610  
Fax: 886-2-2508-0102

**Thailand - Bangkok**  
Tel: 66-2-694-1351  
Fax: 66-2-694-1350

### EUROPE

**Austria - Wels**  
Tel: 43-7242-2244-39  
Fax: 43-7242-2244-393

**Denmark - Copenhagen**  
Tel: 45-4450-2828  
Fax: 45-4485-2829

**France - Paris**  
Tel: 33-1-69-53-63-20  
Fax: 33-1-69-30-90-79

**Germany - Munich**  
Tel: 49-89-627-144-0  
Fax: 49-89-627-144-44

**Italy - Milan**  
Tel: 39-0331-742611  
Fax: 39-0331-466781

**Netherlands - Drunen**  
Tel: 31-416-690399  
Fax: 31-416-690340

**Spain - Madrid**  
Tel: 34-91-708-08-90  
Fax: 34-91-708-08-91

**UK - Wokingham**  
Tel: 44-118-921-5869  
Fax: 44-118-921-5820

06/25/07