

REV.	DATE	ECR NO.	DESCRIPTION
NC	05/18/11	XXXXXX	INITIAL RELEASE
A	06/08/11	2179	THE BODY'S KNURL WAS CHANGED

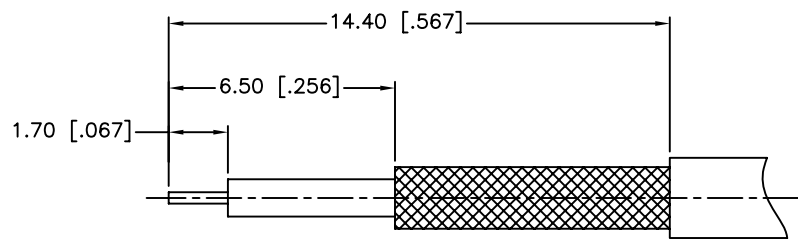
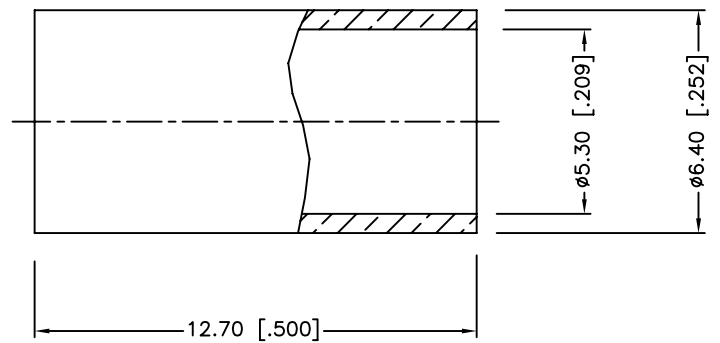
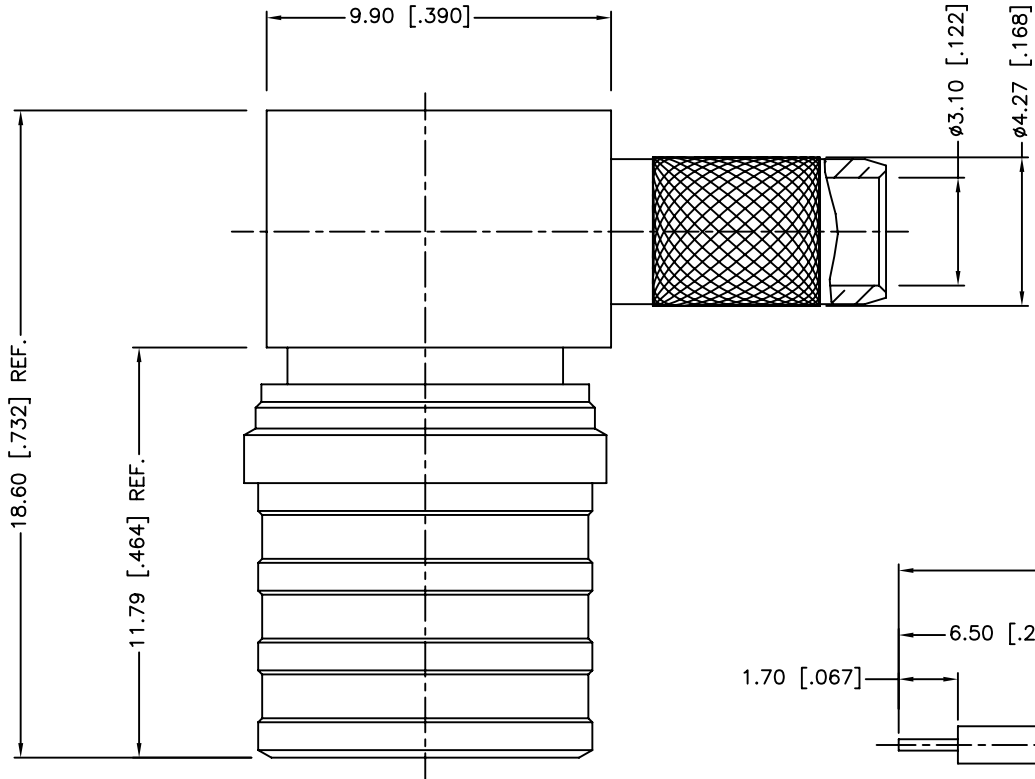
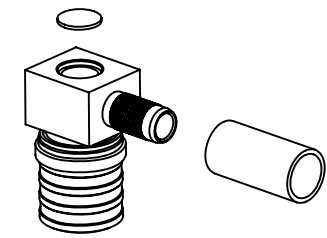
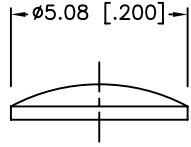

RECOMMENDED CABLE STRIPPING DIM'S

1. CRIMPED FERRULE
HEX. CRIMP SIZE .216"

DESCRIPTION	MATERIAL	FINISH	QTY
7 FERRULE	BRASS	NEXCOTE	1
6 CAP	BRASS	NEXCOTE	1
5 CONTACT PIN	BRASS	GOLD	1
4 SLEEVE	BRASS	NEXCOTE	1
3 OUTER CONTACT	PHOS. BRONZE	NEXCOTE	1
2 INSULATOR	PTFE	NATURAL	1
1 BODY	BRASS	NEXCOTE	1

UNLESS OTHERWISE SPECIFIED DIMENSIONS ARE IN MILLIMETERS. DIMENSIONS IN [] ARE IN INCHES AND FOR CUSTOMER REFERENCE ONLY.

UNLESS OTHERWISE SPECIFIED TOLERANCES FOR MILLIMETERS ARE:
0.5 - 8mm ± 0.20mm
8 - 30mm ± 0.40mm
30 - 120mm ± 0.50mm

UNLESS OTHERWISE SPECIFIED TOLERANCES FOR INCHES ARE:
.020 - .315 = ± 0.007"
.315 - 1.180 = ± 0.015"
1.180 - 4.724 = ± 0.020"

DO NOT SCALE DRAWING

APPROVALS	DATE
DRAWN S.LI	05/18/11
CHECKED	
ISSUED	
SHEET 1 OF 1	
CAD FILE C:/CONNEX/134102.DWG	

Amphenol Connex

PART DESCRIPTION
QMA R/A PLUG FOR RG-58 TYPE CABLE

PART NO.
134102

DWG. NO. 134102.DWG REV. A SIZE A SCALE NA