

TOP VIEW

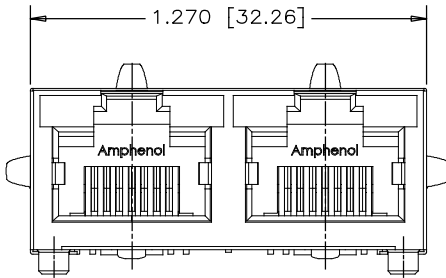

FRONT VIEW

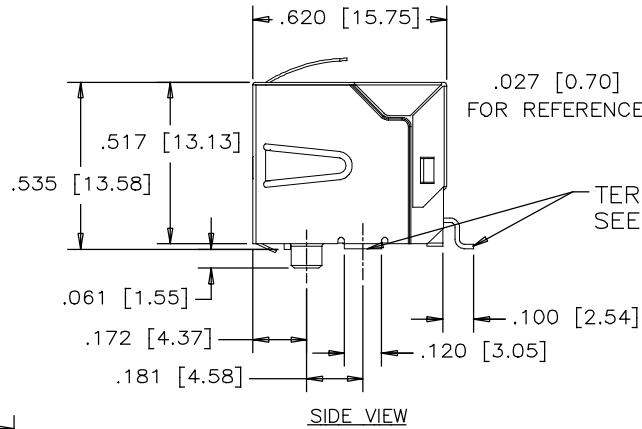

SIDE VIEW

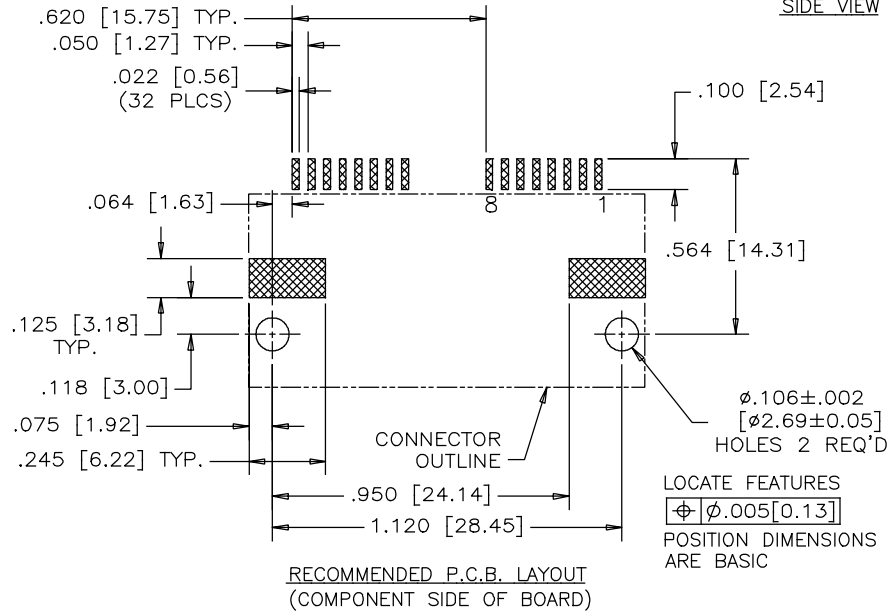

RECOMMENDED P.C.B. LAYOUT
(COMPONENT SIDE OF BOARD)



REVISIONS				
SYM	ZONE	ECN, ERN NO.	DATE	APPRD.
B		CORRECT THE PLATING OF SHIELD	JUL27/12	L.CHAN
C		PROPOSAL	OCT23/14	L.CHAN
D		UPDATED DRAWING	MAR12/15	L.CHAN
E		CORRECT DIMENSION AND PACKAGING QUANTITY	JAN19/16	L.CHAN
F		CORRECT DRAWING	SEP27/16	L.CHAN

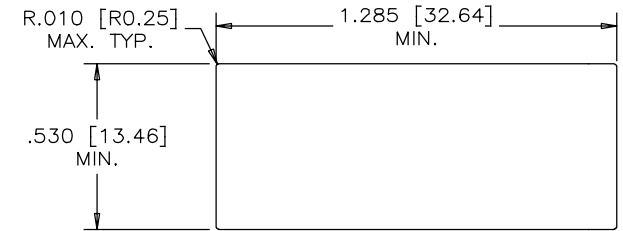

RECOMMENDED PANEL CUTOUT

1. MATERIALS:
HOUSING:

ENGINEERING THERMOPLASTIC
 FLAMMABILITY RATING UL 94V-0
 COLOR: BLACK

CONTACTS:
PLATING:

PHOSPHOR BRONZE
 20 μ" [0.508 MICRONS] MIN. GOLD ON MATING SURFACES.
 50 μ" [1.27 MICRONS] MIN. NICKEL UNDERPLATE.
 100 μ" [2.54 MICRONS] MIN. MATTE-TIN OR GOLD FLASH ON CONTACT TAILS.

SHIELD: COPPER ALLOY PLATED NICKEL

2. COPLANARITY SPECIFICATION:

WITH THE MODULAR JACK SITTING ON A LEVEL SURFACE, THE MAXIMUM GAP BETWEEN THE LEVEL SURFACE OF SHIELD TAB AND ALL TERMINAL TAILS IS .004 [0.10].

PART NUMBER: RJSS-5380-02T

THIS DOCUMENT CONTAINS PROPRIETARY INFORMATION AND SUCH INFORMATION MAY NOT BE DISCLOSED TO OTHERS FOR ANY PURPOSE OR USED FOR MANUFACTURING PURPOSES WITHOUT WRITTEN PERMISSION FROM AMPHENOL CANADA CORP.

MATERIAL -----	DRAWN	Edwin.Qu	DATE	MAR05/12	Amphenol Canada Corp. TITLE 2 PORT, SURFACE MOUNT, RJ45 ,MODULAR JACK, 8 POSITION, 8 CONTACTS, SHIELDED, -ROHS COMPLIANT
	DESIGNED				
	CHECKED	L.CHAN		MAR05/12	
	I. E. APPRD.	Andy.C		MAR05/12	
FINISH -----	Q. A. APPRD.			MAR05/12	DWG C DRAWING NO. P-RJSSE-5380-02T REV. F SCALE 3/1 WT. ----- SURF. ----- SHEET 1 OF 1
	DWG. APPRD.				
	ENG. REL. NO.				
	REF.				
	DIMENSIONS ARE IN	INCHES [mm]	CODE ID. NO.	03554	

REVISIONS				
SYM	ZONE	ECN, ERN NO.	DATE	APPRD.
B		CORRECT THE PLATING OF SHIELD	JUL27/12	L.CHAN
C		PROPOSAL	OCT23/14	L.CHAN
D		UPDATED DRAWING	MAR12/15	L.CHAN
E		CORRECT DIMENSION AND PACKAGING QUANTITY	JAN19/16	L.CHAN
F		CORRECT DRAWING	SEP27/16	L.CHAN

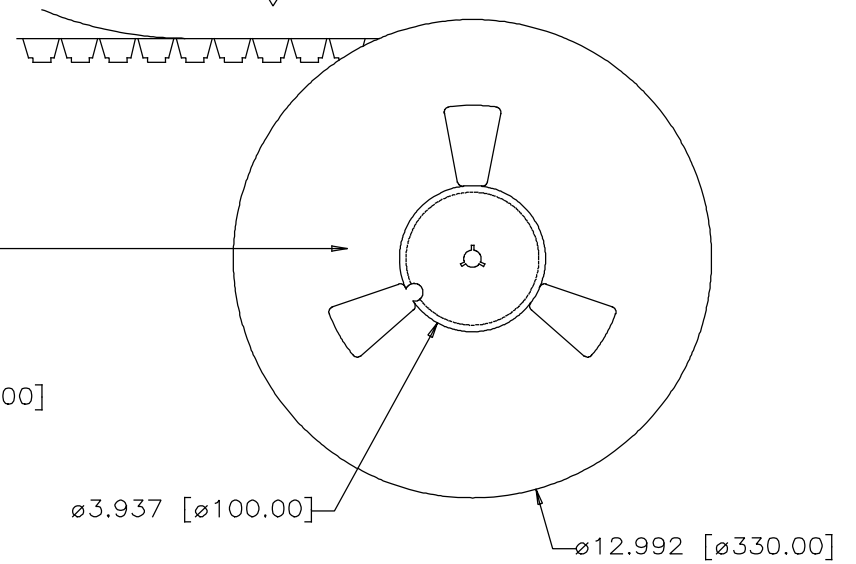
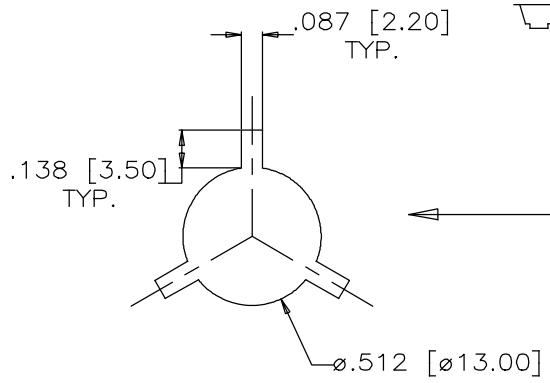
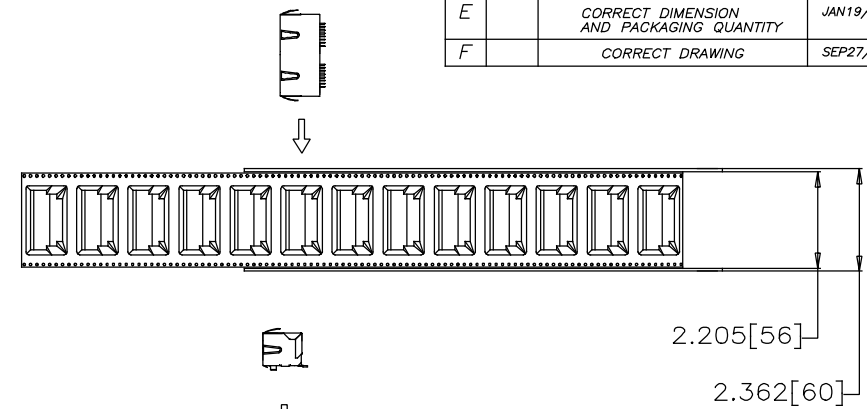
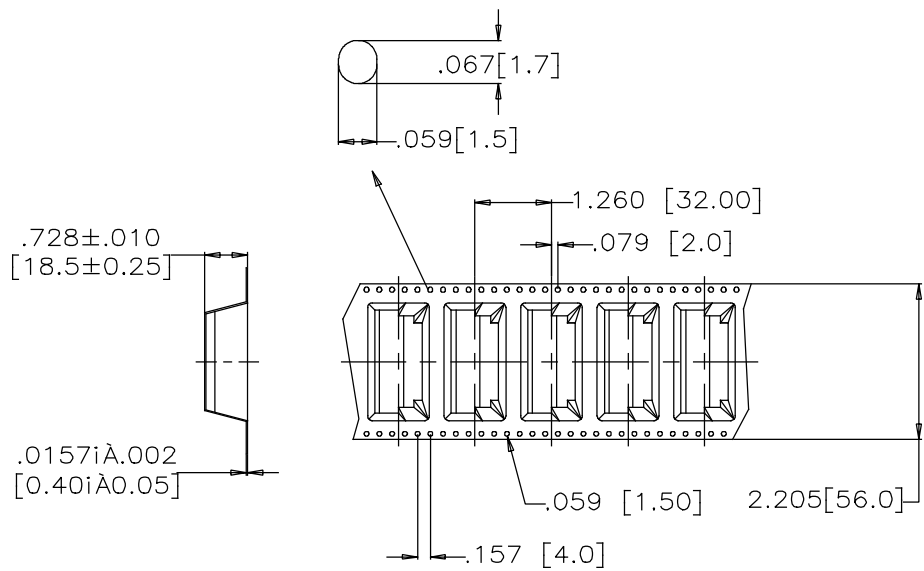

PACKAGING NOTES:

- ONE REEL SHOULD HOLD 100 CONNECTORS.
- 10 EMPTY CAVITIES FOR BOTH TOP AND BOTTOM OF THE CARRIER.
- A FULLY LOADED CARTON SHOULD CONTAIN 5 REELS (500 PCS) OF CONNECTOR.

THIS DOCUMENT CONTAINS PROPRIETARY INFORMATION AND SUCH INFORMATION MAY NOT BE DISCLOSED TO OTHERS FOR ANY PURPOSE OR USED FOR MANUFACTURING PURPOSES WITHOUT WRITTEN PERMISSION FROM AMPHENOL CANADA CORP.

MATERIAL	DRAWN	Edwin.Qu	DATE	MAR05/12	Amphenol Canada Corp.			
	DESIGNED							
FINISH	CHECKED	L.CHAN	DATE	MAR05/12	TITLE 2 PORT, SURFACE MOUNT, RJ45 ,MODULAR JACK, 8 POSITION, 8 CONTACTS,SHIELDED, -ROHS COMPLIANT			
	I. E. APPRD.	Andy.C	DATE	MAR05/12				
	Q. A. APPRD.		DATE	MAR05/12				
	DWG. APPRD.							
	ENG. REL. NO.		DWG	DRAWING NO.	P-RJSSE-5380-02T	REV.	F	
	REF.		C					
	DIMENSIONS ARE IN	INCHES [mm]	CODE ID. NO.	03554	SCALE	WT.	SURF.	SHEET 2 OF 2