

One-cell Lithium-ion/Lithium-polymer battery protection IC with integrated MOS-FET

MC3761 Series

OUTLINE

MC3761 series are protection IC with integrated MOS-FET for protection of the rechargeable Lithium-ion or Lithium-polymer battery. The overcharge, overdischarge and discharging and charging overcurrent protection of the rechargeable one-cell Lithium-ion or Lithium-polymer battery can be detected.

FEATURES

(Unless otherwise specified, Ta=+25°C)

(1) Range and accuracy of detection/release voltage

- Overcharge detection voltage 4.20V to 4.70V, 5mV step Accuracy ±20mV
Accuracy -50/+25mV(Ta=-40 to +85°C)
- Overcharge release voltage Vdet1-0.4V to Vdet1,100mV step Accuracy -30/+20mV (Vdet1=Vrel1)
Accuracy ±30mV (Vdet1≠Vrel1)
- Overdischarge detection voltage 2.00V to 3.30V, 50mV step Accuracy ±30mV
- Overdischarge release voltage Vdet2+0.4V to Vdet2,100mV step Accuracy -30/+40mV (Vdet2=Vrel2)
Accuracy ±90mV (Vdet2≠Vrel2)
- Discharging overcurrent detection voltage +8mV to +110mV, 1mV step Accuracy *1
(Discharging overcurrent detection current (0.140A to 1.95A))
- Discharging overcurrent release voltage Selection from
VDD-0.7V , 1.6V , Vdet3
- Charging overcurrent detection voltage -100mV to -8mV, 1mV step Accuracy *1
(Charging overcurrent detection current) (-0.140A to -1.75A)
- Short detection voltage 0.040V to 0.700V, 5mV step Accuracy ±20 to 50mV

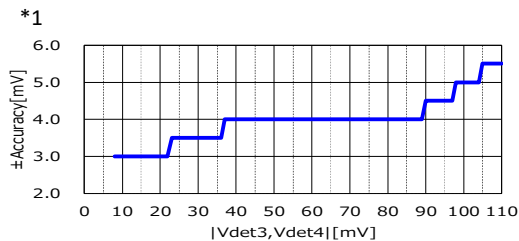

*1
These range and accuracy are the one of the standard setting. It may differ each product. Please refer to an individual specifications about detail parameters.

(2) Range of detection delay time

- Overcharge detection delay time 1.0s fixed
- Overdischarge detection delay time Selection from 20ms, 96ms, 144ms
- Discharging overcurrent detection delay time Selection from 6ms, 8ms, 12ms, 16ms, 20ms, 32ms,
128ms, 256ms, 512ms
- Charging overcurrent detection delay time Selection from 8ms, 16ms, 32ms
- Short detection delay time 150us to 550us, 50us step

(3) 0V battery charge function

Selection from "Inhibition" or "Permission" *2

(4) Low current consumption

- Normal mode Typ. 1.0µA, Max. 1.4µA
- Stand-by mode Max. 0.025µA (In case Overdischarge latch function "Enable")
Max. 0.550µA (In case Overdischarge latch function "Disable")

(5) MOS-FET

- Source to Source on state resistance Typ. 56.5mΩ (@VDD=3.5V)

(6) Absolute maximum ratings

- VDD pin -0.3V to +12V
- V- pin VDD-24V to VDD+0.3V
- Drain-source voltage Max. 24V
- Source current 2.0A
- Total Power Dissipation 0.3W
- Storage temperature -55 to +125°C
- Operation temperature -40 to +85°C

(7) Package type

- PLP-6J 1.40 × 2.00 × 0.50max [mm]

*2 In the case of "0V battery charge inhibition", the setting voltage is 0.90V.

*3 Please inquire to us, if you need another specifications.

PIN CONFIGURATION

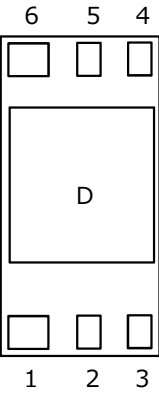
Package	Pin No.	Symbol	Function
PLP-6J			
TOP View  1.40 × 2.00mm typ., t=0.50mm max.	1	S1	Source terminal of discharge FET
	2	VSS	Negative power supply voltage input terminal
	3	VDD	Positive power supply voltage input terminal
	4	NC	No connection
	5	VM	Charger negative voltage input terminal
	6	S2	Source terminal of charge FET
	-	D	Drain terminal of discharge FET and charge FET

PACKAGE DIMENSION

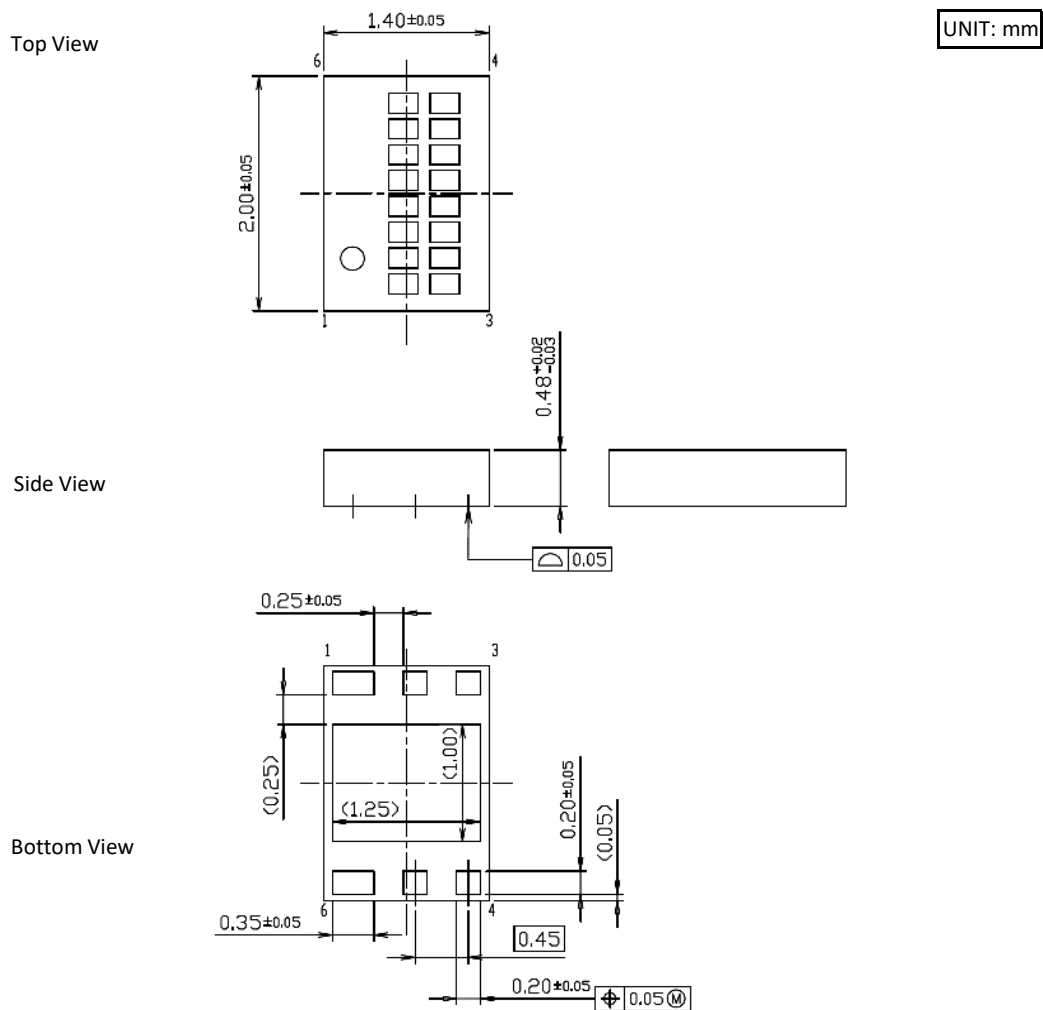

RECOMMEND OPERATION CONDITIONS

ITEM	SYMBOL	MIN.	MAX.	UNIT
Operating Ambient temperature	Topr	-40	85	°C
Operating voltage	Vop	1.5	5.5	V

ELECTRICAL CHARACTERISTICS (Main item)

Ta=25°C

ITEM	SYMBOL	CONDITION	MIN.	TYP.	MAX.	UNIT
Discharge overcurrent release resistance	Rshort	VDD=3.6V, VM=3.6V	10.0	20.0	40.0	kΩ
VM terminal pull-up resistances	Rpu	VDD=2.0V, VM=0V	150	300	600	kΩ
Current consumption	Idd	VDD=4.0V, VM=0V	-	1.0	1.4	μA
Current consumption at stand-by	Istb	VDD=2.0V, VM=VDD, *4	-	-	0.025	μA
		VDD=1.5V, VM=VDD, *5	-	-	0.550	

Ta=25°C

ITEM	SYMBOL	CONDITION	MIN.	TYP.	MAX.	UNIT
Overcharge detection voltage	Vdet1		Vdet1-0.02	Vdet1	Vdet1+0.02	V
Overcharge release voltage	Vrel1	Vdet1=Vrel1	Vrel1-0.03	Vrel1	Vrel1+0.02	V
		Vdet1≠Vrel1	Vrel1-0.03		Vrel1+0.03	
Overdischarge detection voltage	Vdet2		Vdet2-0.03	Vdet2	Vdet2+0.03	V
Overdischarge release voltage1	Vrel2	Vdet2=Vrel2	Vrel2-0.03	Vrel2	Vrel2+0.04	V
		Vdet2≠Vrel2	Vrel2-0.09		Vrel2+0.09	
Discharging overcurrent detection voltage	Vdet3	*6	Vdet3-3.00	Vdet3	Vdet3+3.0	mV
Discharging overcurrent release voltage	Vrel3		VDD-1.0	VDD-0.7	VDD-0.4	V
			*6	1.60	*6	
			*6	Vdet3	*6	
Charging overcurrent detection voltage	Vdet4	*6	Vdet4-3.00	Vdet4	Vdet4+3.00	mV
Short detection voltage	Vshort		Vshort-0.02	Vshort	Vshort+0.02	V
0V battery charge inhibition battery voltage	Vst	When "Inhibition" is selected	0.60	0.90	1.20	V
Overcharge detection delay time	tVdet1	*6	tVdet1*0.8	tVdet1	tVdet1*1.2	s
Overcharge release delay time	tVrel1	*6	tVrel1*0.8	tVrel1	tVrel1*1.2	ms
Overdischarge detection delay time	tVdet2	*6	tVdet2*0.8	tVdet2	tVdet2*1.2	ms
Overdischarge release delay time	tVrel2	*6	tVrel2*0.8	tVrel2	tVrel2*1.2	ms
Discharging overcurrent detection delay time	tVdet3	*6	tVdet3*0.8	tVdet3	tVdet3*1.2	ms
Discharging overcurrent release delay time	tVrel3	*6	tVrel3*0.8	tVrel3	tVrel3*1.2	ms
Charging overcurrent detection delay time	tVdet4	*6	tVdet4*0.8	tVdet4	tVdet4*1.2	ms
Charging overcurrent release delay time	tVrel4	*6	tVrel4*0.8	tVrel4	tVrel4*1.2	ms
Short detection delay time	tshort	*6	tshort*0.7	tshort	tshort*1.3	us

Ta=25°C

ITEM	SYMBOL	CONDITION	MIN.	TYP.	MAX.	UNIT
Drain current of cut off	IDSS	VDS=24V	-	-	1.0	uA
Source to source on state resistance	RSS(on)45	VDD=4.5V , Is=1.0A	46.0	52.5	61.0	mΩ
	RSS(on)42	VDD=4.2V , Is=1.0A	46.0	53.0	62.0	mΩ
	RSS(on)39	VDD=3.9V , Is=1.0A	47.0	54.5	64.0	mΩ
	RSS(on)37	VDD=3.7V , Is=1.0A	47.5	55.5	65.0	mΩ
	RSS(on)35	VDD=3.5V , Is=1.0A	48.0	56.5	67.0	mΩ
	RSS(on)33	VDD=3.3V , Is=1.0A	48.5	58.0	69.0	mΩ
	RSS(on)30	VDD=3.0V , Is=1.0A	49.5	60.5	73.5	mΩ
	RSS(on)25	VDD=2.5V , Is=1.0A	50.0	68.0	87.0	mΩ
Body diode forward voltage	VF	Is=1A	0.55	0.70	0.85	V

*4 In case Overdischarge latch function "Enable"

*5 In case Overdischarge latch function "Disable"

*6 These range and accuracy are the one of the standard setting. It may differ each product.

Please refer to an individual specifications about detail parameters.

Typical application circuit

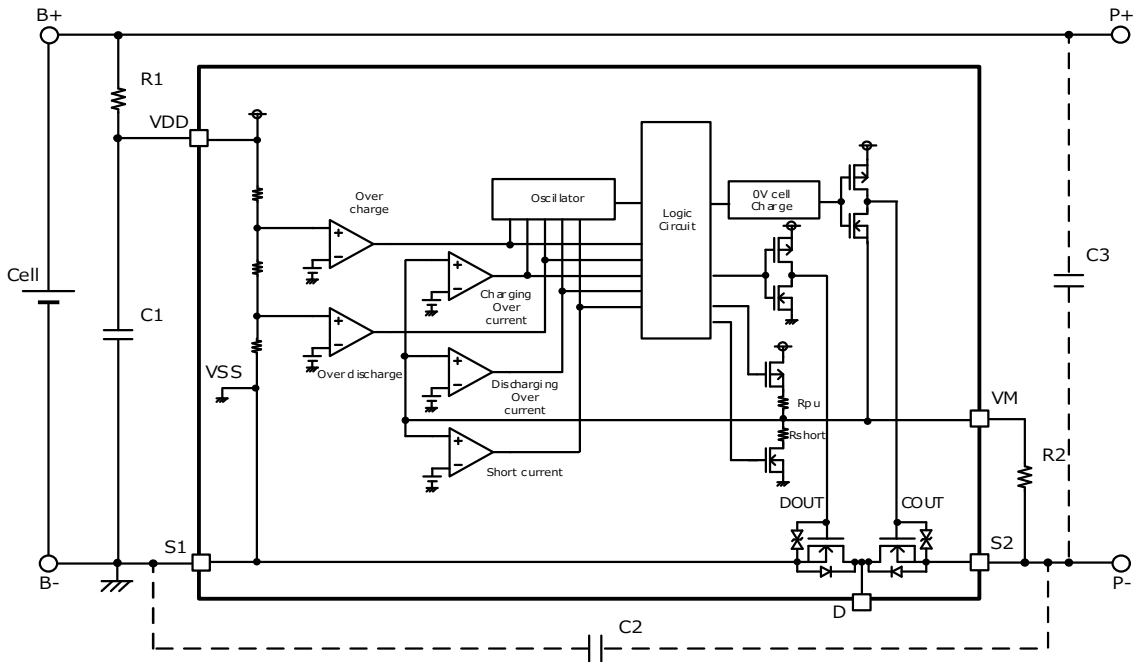

Symbol	Parts	Min.	Typ.	Max.	Purpose
R1	Resistor	-	100Ω	1.0kΩ	For voltage fluctuation, For ESD
C1	Capacitor	0.01uF	0.1uF	1.0uF	For voltage fluctuation
R2	Resistor	-	1.0kΩ	-	Current limit for charger reverse connection
C2	Capacitor	-	0.1uF	-	For exogenous noise
C3	Capacitor	-	0.1uF	-	For exogenous noise

Application hints

The resistors that are inserted into each pin are to protect the IC. They help to remove ESD and latch-up damages. The capacitors help to reduce the effects of transient variations in voltage and electromagnetic waves, and to improve ESD tolerance of the IC.

Please use either C2 or C3, or both of them by request of your application.

These values in the above figure are for example. Please choose appropriate values.

PRODUCT LINEUP

Development state	Product name	Package	Model Code	Optional function			Detection/Release voltage							Detection delay time				Overcurrent		MOS-FET	
				OV battery charge function	Overcharge detection Latch function	Overdischarge detection Latch function	Overcharge detection voltage	Overcharge release voltage	Overcharge release voltage	Overdischarge release voltage	Discharging overcurrent detection voltage	Charging overcurrent detection voltage	Short detection voltage	Overcharge detection delay time	Overdischarge detection delay time	Discharging overcurrent detection delay time	Charging overcurrent detection delay time	Short detection delay time	Discharge current limit (@VDD=3.5V)		Charge current limit (@VDD=3.5V)
							Vdet1	Vrel1	Vdet2	Vrel2	Vdet3	Vdet4	Vshort	tVdet1	tVdet2	tVdet3	tVdet4	tshort	Idischg		Icharge
							V	V	V	V	mV	mV	V	s	ms	ms	ms	ms	us		A
MP	MC3761PK1HAU	PLP-6J	761PK1U	Inhibition	Disable	Enable	4.280	4.180	2.700	2.700	30.0	-30.0	0.060	1.0	96.0	20.0	8.0	300	0.530	0.535	56.5
ES	MC3761AJ2HAU	PLP-6J	761AJ2U	Permission	Disable	Disable	4.455	4.255	2.800	3.200	110.0	-100.0	0.270	1.0	96.0	12.0	8.0	300	1.945	1.785	56.5
ES	MC3761AJ3HAU	PLP-6J	761AJ3U	Permission	Disable	Disable	4.225	4.025	2.800	3.200	37.0	-36.0	0.080	1.0	96.0	12.0	8.0	300	0.655	0.645	56.5
MP	MC3761PK2HAU	PLP-6J	761PK2U	Inhibition	Disable	Enable	4.430	4.130	3.000	3.000	19.0	-12.0	0.055	1.0	96.0	20.0	8.0	300	0.335	0.215	56.5
MP	MC3761PJ2HAU	PLP-6J	761PJ2U	Permission	Disable	Enable	4.380	4.180	2.800	2.800	56.0	-56.0	0.140	1.0	20.0	12.0	16.0	400	0.990	1.000	56.5
MP	MC3761EJ1HAU	PLP-6J	761EJ1U	Permission	Enable	Enable	4.525	4.525	2.700	2.700	20.0	-33.0	0.080	1.0	96.0	512.0	8.0	250	0.355	0.590	56.5
ES	MC3761EK1HAU	PLP-6J	761EK1U	Inhibition	Enable	Enable	4.410	4.410	2.700	2.700	17.0	-17.0	0.047	1.0	20.0	128.0	8.0	200	0.300	0.305	56.5
ES	MC3761PK4HAU	PLP-6J	761PK4U	Inhibition	Disable	Enable	4.475	4.375	2.700	2.700	17.0	-17.0	0.150	1.0	20.0	128.0	8.0	150	0.305	0.310	56.5
ES	MC3761PJ4HAU	PLP-6J	761PJ4U	Permission	Disable	Enable	4.270	4.070	3.000	3.000	50.0	-53.0	0.120	1.0	96.0	12.0	8.0	500	0.900	0.965	56.5

Please inquire to us, if you request a rank other than the above.

NOTES

【Safety Precautions】

- Though Mitsumi Electric Co., Ltd. (hereinafter referred to as "Mitsumi") works continually to improve our product's quality and reliability, semiconductor products may generally malfunction or fail. Customers are responsible for complying with safety standards and for providing adequate designs and safeguards for their hardware, software and systems which minimize risk and avoid situations in which a malfunction or failure of this product could cause loss of human life, bodily injury, or damage to property, including data loss or corruption. Before customers use this product, create designs including this product, or incorporate this product into their own applications, customers must also refer to and comply with (a) the latest versions or all of our relevant information, including without limitation, product specifications, data sheets and application notes for this product and (b) the user's manual, handling instructions or all relevant information for any products which is to be used, or combined with this products. Customers are solely responsible for all aspects of their own product design or applications, including but not limited to (a) determining the appropriateness of the use of this product in such design or applications; (b) evaluating and determining the applicability of any information contained in this document, or in charts, diagrams, programs, algorithms, sample application circuits, or any other referenced documents; and (c) validating all operating parameters for such designs and applications. Mitsumi assumes no liability for customers' product design or applications.
- This product is intended for applying to computers, OA units, communication units, instrumentation units, machine tools, industrial robots, AV units, household electrical appliances, and other general electronic units.

【Precautions for Product Liability Act】

- No responsibility is assumed by us for any consequence resulting from any wrong or improper use or operation, etc. of this product.

【ATTENTION】

- This product is designed and manufactured with the intention of normal use in general electronics. No special circumstance as described below is considered for the use of it when it is designed. With this reason, any use and storage under the circumstances below may affect the performance of this product. Prior confirmation of performance and reliability is requested to customers.
 - Environment with strong static electricity or electromagnetic wave
 - Environment with high temperature or high humidity where dew condensation may occur
- This product is not designed to withstand radioactivity, and must avoid using in a radioactive environment.
- This specification is written in Japanese and English. The English text is faithfully translated into the Japanese. However, if any question arises, Japanese text shall prevail.