

PRODUCT NUMBER
72479-WXY1
72479-WXY1LF

PRODUCT NO.
72479-W1Y1

PRODUCT NO.
72479-W2Y1

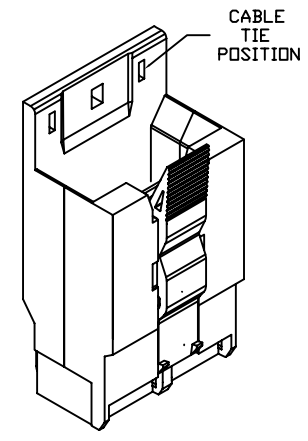
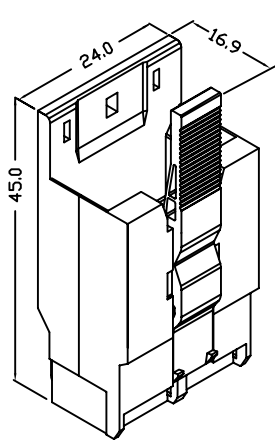
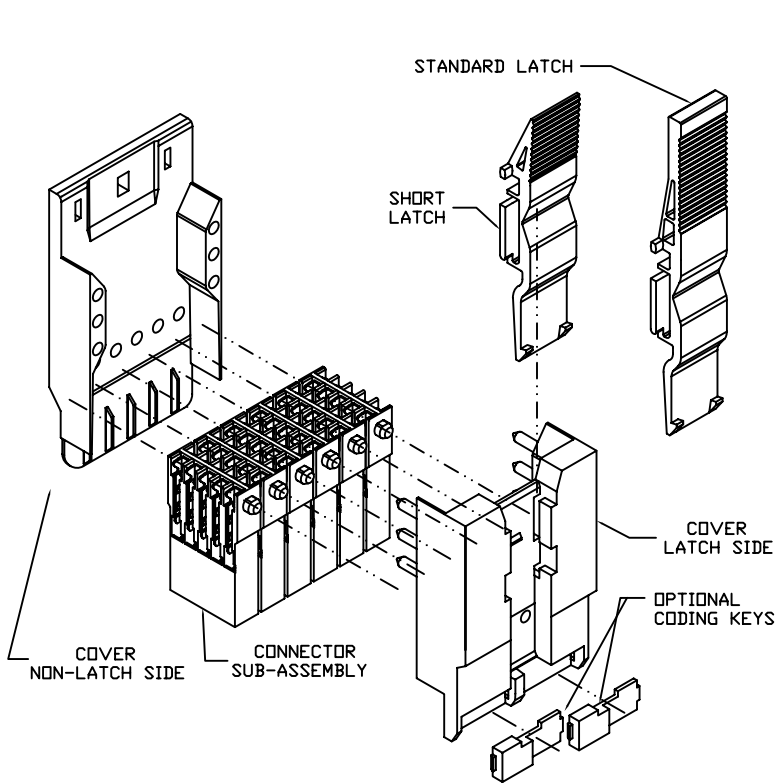

STANDARD LATCH FINGER
FOR CABLE TIE BELOW
LATCH FINGER AND EASIEST
ACCESS TO LATCH FINGER

SHORT LATCH FINGER
FOR CABLE TIE ABOVE
LATCH FINGER AND LARGER
CABLE SIZE CAPACITY

mat'l. code				surface		tolerance		projection		product family	
SEE NOTES				ASME Y14.5		ASME Y14.5				METRAL CABLE	
ltr	ec'n no	dr	date	tolerances unless otherwise specified						title	
A	V71561	JRV	11/5/97	angles		X #1		MM		5X12 UNSHIELDED CABLE CONNECTOR KIT	
B	V12695	EPK	11/14/01		XX #05	XXX #020		scale 1:1		dwg no	
C	V03-0827	HTB	7/24/03	0° ±2'					sheet 1 of 3		size
D	V05-0599	VS	9/8/05	dr	J. VOLSTORF	11/5/97				72479	
E	V06-0613	JRV	2006-06-22	engr	J. VOLSTORF	11/5/97				A4	
				chr	J. VOLSTORF	11/5/97				type	
				appd	J. VOLSTORF	11/5/97					
sheet	revision	E	E	E							
index	sheet	1	2	3							

PRODUCT NUMBER
72479-WXY1

NOTES:

1. SEE APPLICATION SPECIFICATION GS-20-003 FOR INSTRUCTIONS ON WIRE INSERTION AND ASSEMBLY OF COMPONENTS FOR CONNECTORS.
2. PLUGS INTO STANDARD METRAL 5-ROW HEADERS AND SHROUDS.
3. MAXIMUM CABLE DIAMETER
STANDARD LATCH = 9.5mm
SHORT LATCH = 11.5mm
* THE USE OF MULTIPLE CABLES OR THE STRIPPING OF THE CABLE JACKET WILL ALLOW THE USER TO OVERCOME SOME RESTRICTIONS.
4. THE PRODUCTS WHERE THE PART NUMBERS END IN LF MEET THE EUROPEAN UNION DIRECTIVES AND OTHER COUNTRY REGULATIONS AS DESCRIBED IN GS-22-008.
5. THESE PRODUCTS LISTED ON THIS DRAWING WILL NOT WITHSTAND WAVE SOLDER OR REFLOW OPERATIONS.
6. FOR LEADFREE PART NUMBERS, ADD AN 'LF' SUFFIX.
EXAMPLE:72479-WXY1LF

ORDERING INFORMATION FOR KITS AND PARTS
EACH KIT (CONNECTOR) CONSIST OF:
6 CONNECTOR SUB-ASSEMBLIES
1 COVER, NON-LATCH SIDE
1 COVER, LATCH SIDE
1 LATCH FINGER

ORDER KITS 72479-WXY1 WHERE
PLATING ON CONTACT AREA.
W=1 FOR 0.8 um GOLD
W=2 FOR 2.0 um GOLD
W=3 FOR 1.3 um GOLD
W=9 FOR 0.8 um GXT
LATCH FINGER SIZE
X=0 FOR NO LATCH
X=1 FOR STANDARD LATCH FINGER
X=2 FOR SHORT LATCH FINGER
COPPER WIRE SIZE
Y=1 FOR 26 TO 24 GAGE
Y=2 FOR 30 TO 28 GAGE

MATERIAL

INSULATORS, COVERS AND KEYS
GLASS FILLED 612 POLYAMIDE (UL 94 V-0)
LATCH FINGERS
POLYETHERIMIDE (UL 94 V-0)
CONTACTS
PHOSPHOR BRONZE
SnPb FINISH ON IDC DIMPLES

OPTIONAL CODING KEYS

PART NUMBER 72388-OAA1
18 VARIETIES AA = 01 TO 18
USE IN CONJUNCTIONS WITH HEADER CODING
KEYS 70274-001 KEYS 1 TO 18 RESPECTIVELY

COMPONENT PART NUMBERS AND INFORMATION

CONNECTOR SUBASSEMBLY
PART NUMBER 72387-WOY1
* 6 REQUIRED PER CONNECTOR
PLATING ON CONTACT AREA.
W=1 FOR 0.8 um GOLD
W=2 FOR 2.0 um GOLD
W=3 FOR 1.3 um GOLD
W=9 FOR 0.8 um GXT
COPPER WIRE SIZE
Y=1 FOR 26 TO 24 GAGE
Y=2 FOR 30 TO 28 GAGE

COVER, NON-LATCH SIDE COVER, LATCH SIDE
PART NUMBER 72512-0011 PART NUMBER 72512-0021
SHORT LATCH FINGER STANDARD LATCH FINGER
PART NUMBER 72389-0011 PART NUMBER 70289-001

mat'l. code		surface		tolerance		projection		product family	
SEE NOTES		ASME Y14.5		ASME Y14.5				METRAL CABLE	
ltr	ecn no	dr	date	tolerances unless otherwise specified		MM		title	
E				angles	X #1			5X12 UNSHIELDED CABLE CONNECTOR KIT	
				0° ±2'	.XX ±05	scale 1:1		dwg no	
				dr	J. VOLSTORF	11/5/97		sheet 2 of 3	
				engr	J. VOLSTORF	11/5/97		72479	
				chr	J. VOLSTORF	11/5/97		A4	
				appd	J. VOLSTORF	11/5/97		type	
sheet	revision							CUSTOMER Drawing	
index	sheet								

PRODUCT NUMBER
72479-WXY1LF

SEE NOTE 6

ORDERING INFORMATION FOR KITS AND PARTS
EACH KIT (CONNECTOR) CONSIST OF:
6 CONNECTOR SUB-ASSEMBLIES
1 COVER, NON-LATCH SIDE
1 COVER, LATCH SIDE
1 LATCH FINGER

ORDER KITS 72479-WXY1LF WHERE
PLATING ON CONTACT AREA.
W=1 FOR 0.8 um GOLD
W=2 FOR 2.0 um GOLD
W=3 FOR 1.3 um GOLD
W=9 FOR 0.8 um GXT

LATCH FINGER SIZE
X=0 FOR NO LATCH
X=1 FOR STANDARD LATCH FINGER
X=2 FOR SHORT LATCH FINGER

COPPER WIRE SIZE
Y=1 FOR 26 TO 24 GAGE
Y=2 FOR 30 TO 28 GAGE

MATERIAL
INSULATORS, COVERS AND KEYS
GLASS FILLED 612 POLYAMIDE (UL 94 V-0)
LATCH FINGERS
POLYETHERIMIDE (UL 94 V-0)
CONTACTS
PHOSPHOR BRONZE
SN SOLDER FINISH ON IDC DIMPLES (LEAD FREE)

OPTIONAL CODING KEYS
PART NUMBER 72388-0AA1LF
18 VARIETIES AA = 01 TO 18
USE IN CONJUNCTIONS WITH HEADER CODING
KEYS 70274-001 KEYS 1 TO 18 RESPECTIVELY

COMPONENT PART NUMBERS AND INFORMATION

CONNECTOR SUBASSEMBLY
PART NUMBER 72387-W0Y1LF
* 6 REQUIRED PER CONNECTOR
PLATING ON CONTACT AREA.
W=1 FOR 0.8 um GOLD
W=2 FOR 2.0 um GOLD
W=3 FOR 1.3 um GOLD
W=9 FOR 0.8 um GXT
COPPER WIRE SIZE
Y=1 FOR 26 TO 24 GAGE
Y=2 FOR 30 TO 28 GAGE

COVER, NON-LATCH SIDE COVER, LATCH SIDE
PART NUMBER 72512-0011LF PART NUMBER 72512-0021LF
SHORT LATCH FINGER STANDARD LATCH FINGER
PART NUMBER 72389-0011LF PART NUMBER 70289-001LF

mat'l. code		surface		tolerance		projection		product family	
SEE NOTES		ASME Y14.5		ASME Y14.5				METRAL CABLE	
ltr	ecn no	dr	date	tolerances unless otherwise specified		MM		title	
E				angles	X ±1	MM		5X12 UNSHIELDED CABLE CONNECTOR KIT	
				0° ±2'	.XX ±05	scale 1:1		dwg no	
					.XXX ±020			sheet 3 of 3	
		dr	J. VOLSTORF	11/5/97				72479	
		engr	J. VOLSTORF	11/5/97				A4	
		chr	J. VOLSTORF	11/5/97				type	
		appd	J. VOLSTORF	11/5/97				CUSTOMER Drawing	
sheet index	revision sheet								