

PRODUCT DATA DRAWING

REVISION HISTORY			
REV	DESCRIPTION	DATE	APPROVED
-	DCN 39255	07/12	STW

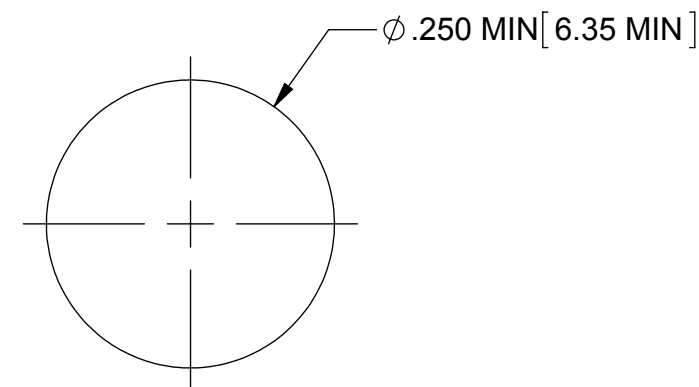
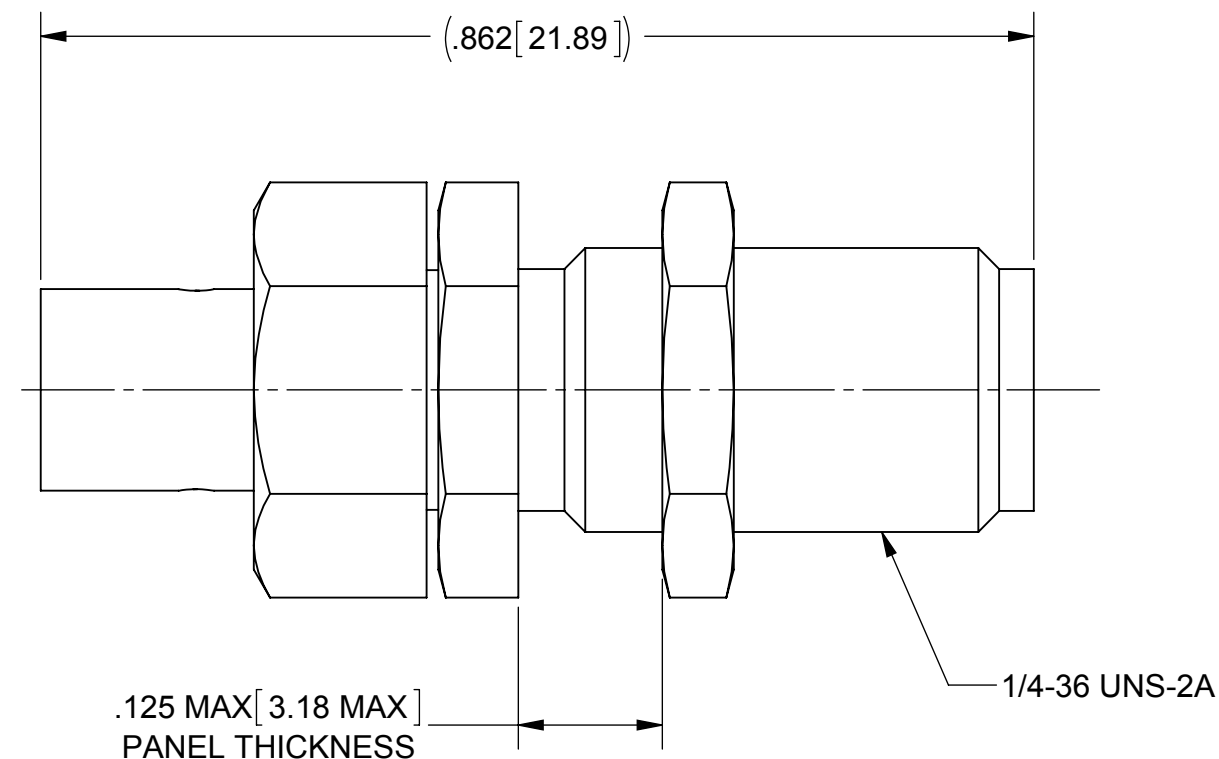
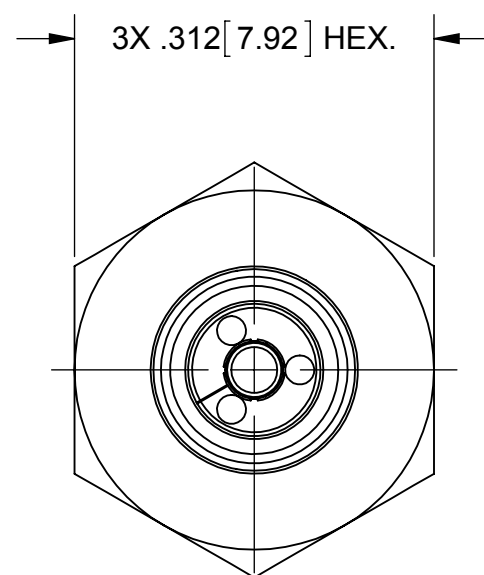

RECOMMENDED MOUNTING HOLE

MATERIAL:

BODY, INSERT,
HEX NUT &
CLAMP NUT:

STAINLESS STEEL PER AMS-5640,
ALLOY UNS S30300, TYPE 1

CONTACTS:

BERYLLIUM COPPER PER ASTM B196,
ALLOY No. UNS C17300, TD04

FERRULE:

BRASS PER ASTM B16, ALLOY UNS No. C36000

BEAD:

ULTEM 1000 PER ASTM D5205

FINISH:

BODY, INSERT,
HEX NUT &
CLAMP NUT:

PASSIVATED PER AMS-2700

CONTACTS &
FERRULE:

GOLD PER ASTM B488, TYPE II,
CODE C, CLASS 1.27, OVER NICKEL
PER AMS-QQ-N-290, CLASS 1, .00005" MIN.

PERFORMANCE:

IMPEDANCE: 50 OHMS
FREQ. RANGE: DC TO 34.0 GHz
VSWR: 1.20:1 DC TO 34.0 GHz
OPERATING TEMP.: -55°C TO +125°C

MATERIAL: SEE NOTES	DIMENSIONS ARE IN INCHES TOLERANCES: FRACTIONAL: ±1/64 ANGULAR: X° ±1'0" X°X' ±15'	UNLESS OTHERWISE SPECIFIED 1) ALL DIMENSIONS ARE IN INCHES (MILLIMETERS) 2) ALL DIMENSIONS ARE AFTER PLATING. 3) BREAK CORNERS & EDGES .005 R. MAX. 4) CHAM. 1ST & LAST THREADS. 5) SURFACE ROUGHNESS 63-MIL-STD-10. 6) DIA: 'S ON COMMON CENTERS TO BE CONCENTRIC WITHIN .005 T.I.R. 7) REMOVE ALL BURRS	SV Microwave, Inc. 2400 Centrepark West Drive, Suite 100 West Palm Beach, FL 33409
FINISH: SEE NOTES	DECIMAL: X ±.030 .XX ±.010 .XXX ±.005	INTERPRET DIMENSIONS AND TOLERANCES PER ASME Y14.5M - 1994	TITLE: SVK BLKD JACK FOR Ø.141 S.R. CABLE
SURFACE AREA: N/A	THIRD ANGLE PROJECTION	DRAWN: NHR 07/30/12	SIZE: B CAGE CODE: 95077 DWG. NO.: SF1521-60044
PROPRIETARY THE INFORMATION CONTAINED IN THIS DRAWING IS THE SOLE PROPERTY OF SV MICROWAVE, INC. ANY REPRODUCTION IN PART OR AS A WHOLE WITHOUT THE WRITTEN PERMISSION OF SV MICROWAVE, INC IS PROHIBITED.		CHECKED: STW 07/30/12	SCALE: 6:1
		APPROVED: STW 07/30/12	SHEET 1 OF 1