



# **GlobalTech Display**

*A Professional LCD Displays Provider*

## **TFT LCD Display Specification**

**PN: GLT043800480IH2-RTP**

### Overview:

- 4.3" Diagonal
- IPS, Full View Angle
- Driver: HX8264-D06+HX8664-B
- 16.7M Colors
- 500 Nits
- 800 x 480 Pixels
- Transmissive/Normally Black
- RGB-24bit Interface
- Resistive Touch Panel
- RoHS Compliant

9825 Widmer Road, Lenexa, KS 66215, USA | Tel: 913-828-5685 Fax: 913-273-4397

Email: [sales@gtdisplays.com](mailto:sales@gtdisplays.com) Website: [www.gtdisplays.com](http://www.gtdisplays.com)

# Table of Contents

1. Record of Revision.....	2
2. General Specifications.....	3
3. Input / Output Terminals.....	4
4. Absolute Maximum Rating.....	5
5. Electrical Characteristics.....	5
6. Interface Timing.....	8
7. Optical Characteristics.....	15
8. Environmental / Reliability Tests.....	18
9. Mechanical Drawing.....	19
10. Packing.....	20
11. TFT-LCD Module Inspection Criteria.....	21
12. Precautions for Use of LCD modules.....	25

# 1. Record of Revision

Rev	Issued Date	Description	Editor
1.0	2018/03/28	First Release	ZHP

## 2. General Specifications

Feature		Spec
Characteristics	Size	4.3 inch
	Resolution	800(horizontal) x 480(Vertical)
	Interface	RGB-24bit
	Connect type	Connector
	Display Colors	16.7M
	Pixel pitch (mm)	0.1188 x 0.1122
	Pixel Configuration	R.G.B.-Stripe
	Display Mode	Normally black
	LCD Driver IC	HX8264-D06 + HX8664-B
	Viewing Direction	Full view
Mechanical	LCM (W x H x D) (mm)	105.50 x 67.20 x 4.05
	Active Area(mm)	95.04 x 53.86
	With or without TSP	RTP
	Weight (g)	~60g
	LED Numbers	10 LEDS

Note 1: Requirements on Environmental Protection: RoHs

Note 2: LCM weight tolerance: +/- 5%

### 3. Input / Output Interface

#### LCD PIN-MAP

No.	Symbol	Description
1	VLED-	Backlight LED Cathode
2	VLED+	Backlight LED Anode.
3	GND	Ground
4	VDD	Power supply
5~12	R0~R7	Data bus
13~20	G0~G7	Data bus
21~28	B0~B7	Data bus
29	GND	Ground
30	DCLK	Dot clock signal input. Latching input data at its rising edge.
31	DISP	Normally pulled high. DISP="1": Normally operation (Default) DISP="0": Timing controller, source driver will turn off ,all output are High-Z.
32	HSYNC	Horizontal sync input. Negative polarity.
33	VSYNC	Vertical sync input. Negative polarity..
34	DE	Data enable input. Active high to enable the input data bus under "DE Mode."
35	NC	No connect
36	GND	System Ground
37	XR	The right side signal pin of RTP
38	YD	The bottom side signal pin of RTP
39	XL	The left side signal pin of RTP
40	YU	The top side signal pin of RTP

## 4. Absolute Maximum Rating

Item	Symbol	MIN	Typ	MAX	Unit	Remark
Supply Voltage	VDD	-0.5	-	3.96	V	-
Operating Temperature	TOPR	-30	-	85	°C	-
Storage Temperature	TSTG	-30	-	85	°C	

## 5. Electrical Characteristics

### 5.1 Driving TFT LCD Panel

Parameter	Symbol	Spec.			Unit	Condition
		Min.	Typ.	Max.		
Power supply voltage	VDD	2.7	3.3	3.6	V	-
Power supply voltage	VDDA	6.5	-	13.5	V	-
Low level input voltage	V <sub>IL</sub>	0	-	0.3VDD	V	For digital circuit
High level input voltage	V <sub>IH</sub>	0.7VDD	-	VDD	V	For digital circuit
Output low voltage	V <sub>OL</sub>	-	-	VSS+0.4	V	I <sub>OL</sub> =400μA
Output high voltage	V <sub>OH</sub>	VDD-0.4	-	-	V	I <sub>OH</sub> =-400μA
Pull low/high resistance	R <sub>i</sub>	200	250	300	kΩ	For the digital input pin @VDD=3.3V
Input leakage current	I <sub>ii</sub>	-	-	±1	μA	For digital circuit
Digital Operation current	I <sub>dd</sub>	-	5	14	mA	Dual gate mode or Cascade mode slave, Fclk=50MHz, LD=48KHz, VDD=3.3V, CABC disable, No load
		-	7	16	mA	Cascade mode master, Fclk=50MHz, LD=48KHz, VDD=3.3V, CABC disable, No load
Digital stand-by current	I <sub>st1</sub>	-	10	50	μA	Clock & all functions are stopped
Analog Operating current	I <sub>dda</sub>	-	6	8	mA	No load, Fclk=50MHz, FLD=48KHz @ VDDA=10V, V1=8V, V14=0.4V
Analog Stand-by current	I <sub>st2</sub>	-	10	50	μA	No load, clock & all functions are stopped
Input level of V1~V7	V <sub>ref1</sub>	0.4VDDA	-	VDDA-1	V	Gamma correction voltage input
Input level of V8~V14	V <sub>ref2</sub>	0.1	-	0.6VDDA	V	Gamma correction voltage input
Output Voltage deviation	V <sub>od1</sub>	-	±20	±35	mV	V <sub>o</sub> =VSSA+0.1V~VSSA+0.5V & V <sub>o</sub> =VDDA-0.5V~VDDA-0.1V
Output Voltage deviation	V <sub>od2</sub>	-	±15	±20	mV	V <sub>o</sub> =VSSA+0.5V~VDDA-0.5V
Output Voltage Offset between Chips	V <sub>oc</sub>	-	-	±20	mV	V <sub>o</sub> =VSSA+0.5V~VDDA-0.5V
Dynamic Range of Output	V <sub>dr</sub>	0.1	-	VDDA-0.1	V	SO1~SO1200
Sinking Current of Outputs	I <sub>OLy</sub>	80	-	-	μA	SO1~SO1200; V <sub>o</sub> =0.1V vs. 1.0V, VDDA=13.5V
Driving Current of Outputs	I <sub>OHy</sub>	80	-	-	μA	SO1~SO1200; V <sub>o</sub> =0.1V vs. 12.5V, VDDA=13.5V
Resistance of Gamma Table	R <sub>g</sub>	0.7*R <sub>n</sub>	1.0*R <sub>n</sub>	1.3*R <sub>n</sub>	Ω	R <sub>n</sub> : Internal gamma resistor

## 5.2 LED Driving Conditions

Item	Symbol	MIN	TYP	MAX	Unit	Remark
Forward Current	$I_F$	-	40	-	mA	
Forward Voltage	$V_F$	15.0	16.0	17.0	V	
Backlight Power consumption	$W_{BL}$	-	0.640	-	W	
LED Lifetime		-	50000	-	Hour	

Note 1: Each LED:  $I_F = 20 \text{ mA}$ ,  $V_F = 3.2 \pm 0.2 \text{ V}$ .

Note 2: Optical performance should be evaluated at  $T_a = 25^\circ \text{C}$  only.

Note 3: If LED is driven by high current, high ambient temperature & humidity condition. The life Time of LED will be reduced. Operating life means brightness goes down to 50% initial brightness. Typical operating life time is estimated data.

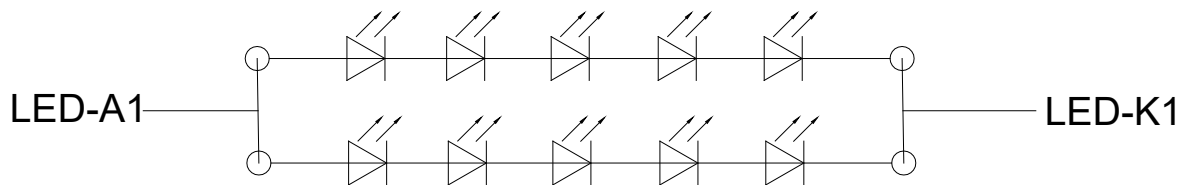
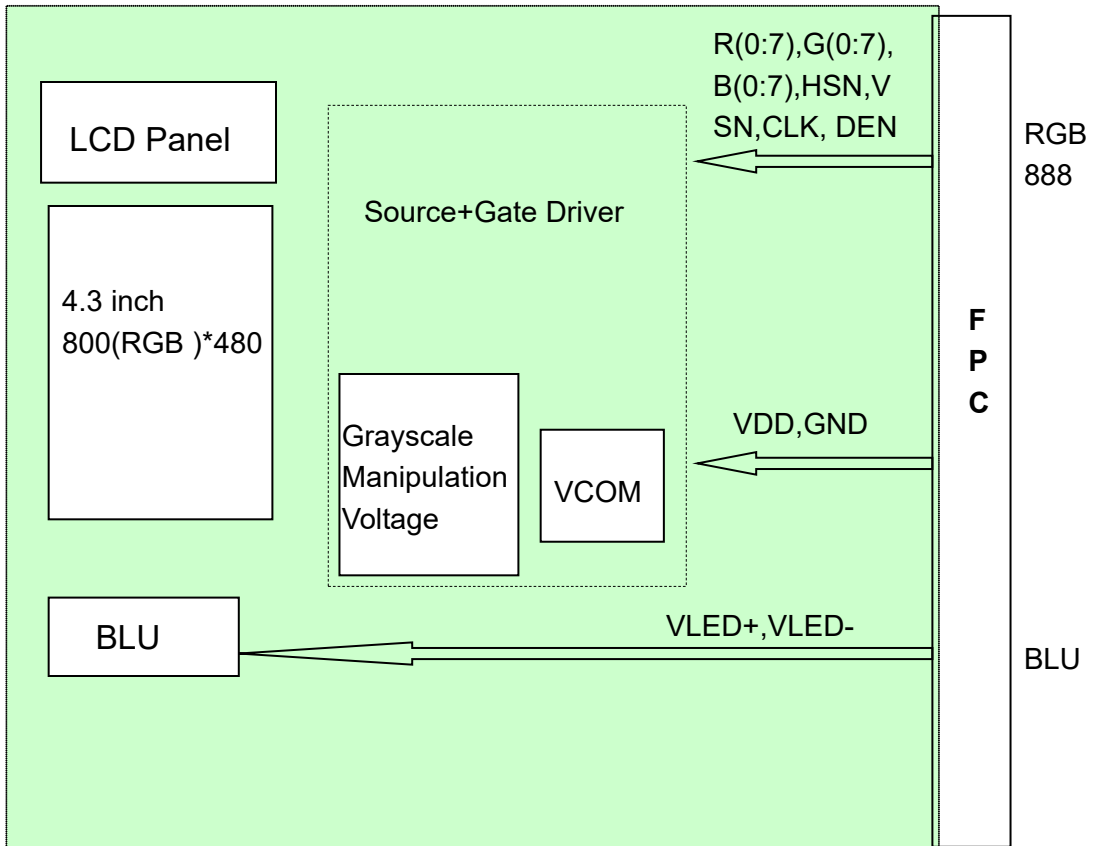

Figure: LED connection of backlight (Constant Current)

### 5.3 Block Diagram





## 6. Interface Timing

### 6.1 Power Sequence

Power on/off control:

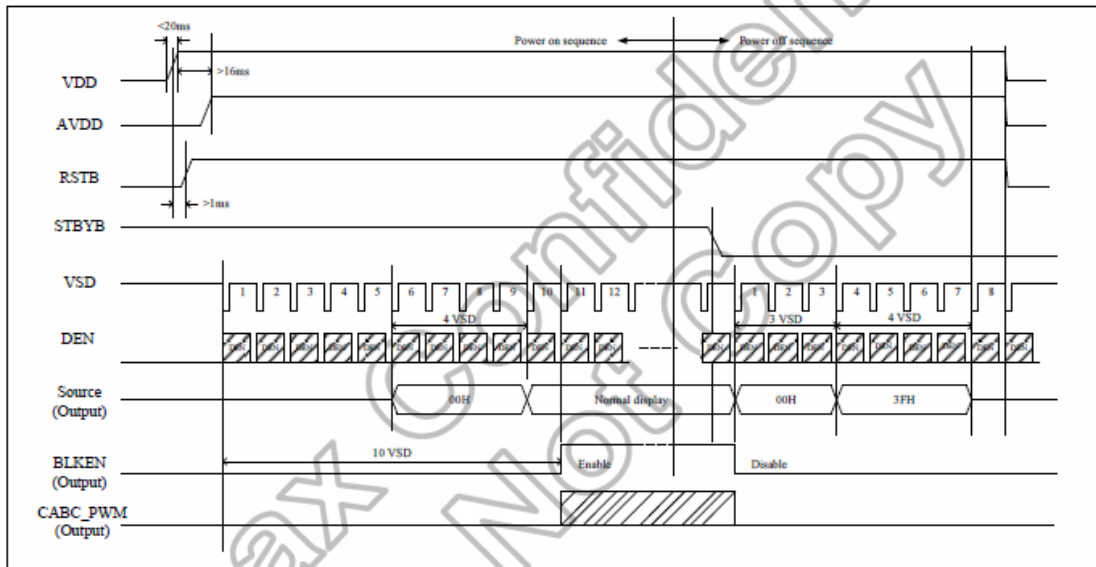

Enter and exit standby mode sequence:

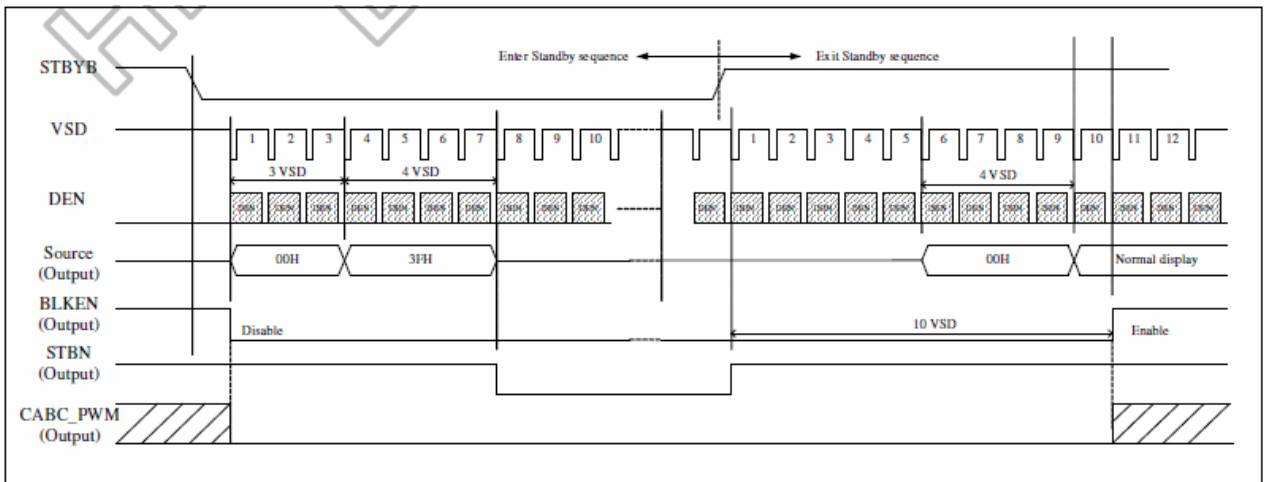

## 6.2 AC Characteristics

### 6.2.1 AC electrical characteristics

Parameter	Symbol	Spec.			Unit
		Min.	Typ.	Max.	
HS setup time	$T_{hst}$	8	-	-	ns
HS hold time	$T_{hhd}$	8	-	-	ns
VS setup time	$T_{vst}$	8	-	-	ns
VS hold time	$T_{vhd}$	8	-	-	ns
Data setup time	$T_{dsu}$	8	-	-	ns
Data hold time	$T_{dhd}$	8	-	-	ns
DE setup time	$T_{esu}$	8	-	-	ns
DE hold time	$T_{ehd}$	8	-	-	ns
VDD Power On Slew rate	$T_{POR}$	-	-	20	ms
RSTB pulse width	$T_{Rst}$	10	-	-	us
CLKIN cycle time	$T_{cph}$	20	-	-	ns
CLKIN pulse duty	$T_{cwh}$	40	50	60	%
Output stable time	$T_{sst}$	-	-	6	us

### 6.2.2 Data input format

- Horizontal timing

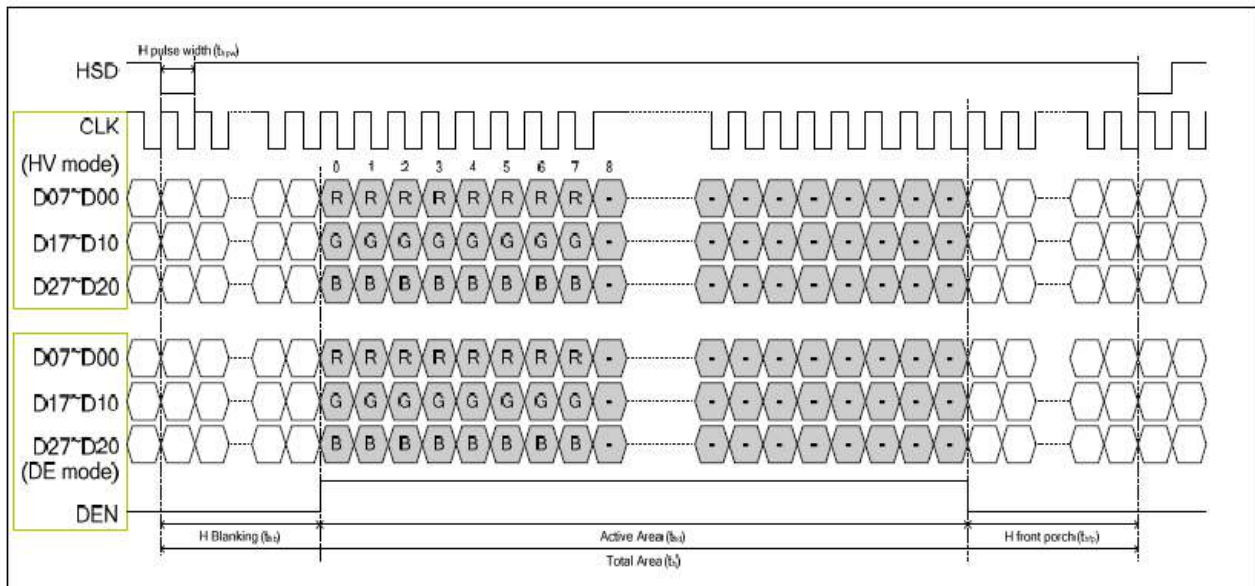

- Vertical timing

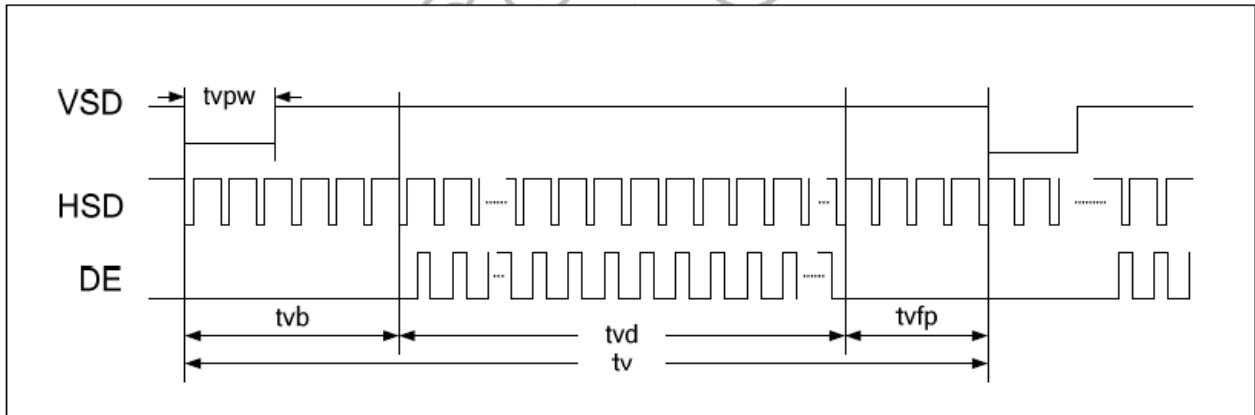

- Horizontal timing

Parameter	Symbol	Spec.			Unit
		Min.	Typ.	Max.	
Horizontal Display Area	thd	800			DCLK
DCLK frequency	fclk	-	30	50	MHz
One Horizontal Line	th	862	1056	1200	DCLK
HS pulse width	thpw	1	-	40	DCLK
HS Back Porch (Blanking)	thb	46			DCLK
HS Front Porch	thfp	16	210	354	DCLK
DE mode Blanking	th-thd	85	256	400	DCLK

- Vertical timing

Parameter	Symbol	Spec.			Unit
		Min.	Typ.	Max.	
Vertical Display Area	tvd	480			$T_H$
VS period time	tv	513	525	650	$T_H$
VS pulse width	tvpw	3	-	20	$T_H$
VS Back Porch (Blanking)	tvb	23			$T_H$
VS Front Porch	tvfp	7	22	147	$T_H$
DE mode Blanking	tv-tvd	30	45	170	$T_H$

## 6.3 Waveform

### 6.3.1 Timing waveform table

Parameter	Symbol	Min.	Typ.	Max.	Unit	Conditions
CLKIN Frequency	Fclk	-	40	50	MHz	VDD=3.0V~3.6V
CLKIN Cycle Time	Tclk	20	25	-	ns	-
CLKIN Pulse Duty	Tcwh	40	50	60	%	Tclk
Time from HSD to Source Output	Thso		64		CLKIN	-
Time from HSD to LD	Thld		64		CLKIN	-
Time from HSD to STV	Thstv		2		CLKIN	-
Time from HSD to CKV	Thckv		20		CLKIN	-
Time from HSD to OEV	Thoev		4		CLKIN	-
LD Pulse Width	Twld		10		CLKIN	-
CKV Pulse Width	Twckv		66		CLKIN	-
OEV Pulse Width	Twoev		74		CLKIN	-

### 6.3.2 Timing diagram

#### 6.3.2.1 Input clock and data timing waveform:

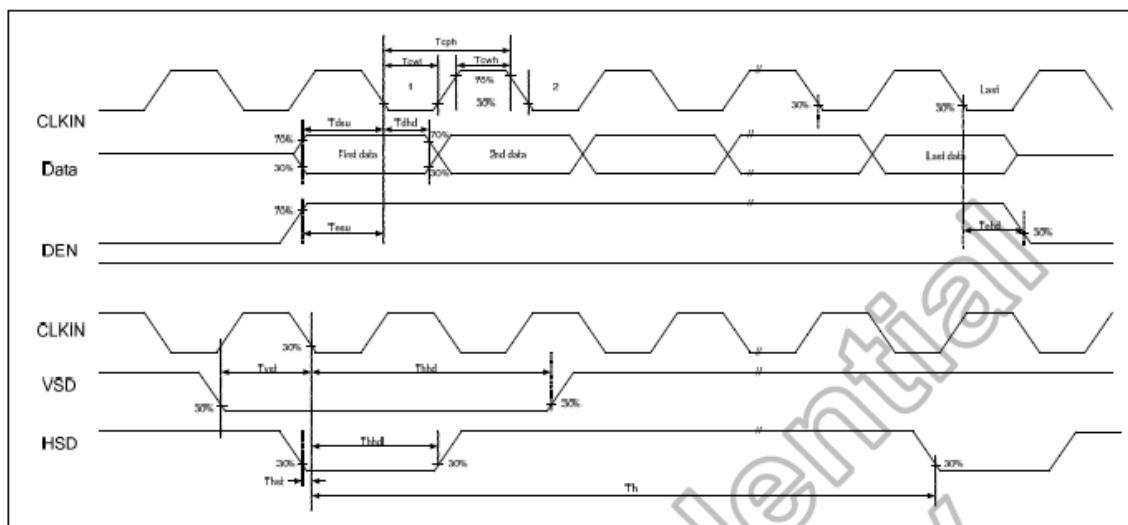

### 6.3.2.2 Source output timing waveform (Cascade):

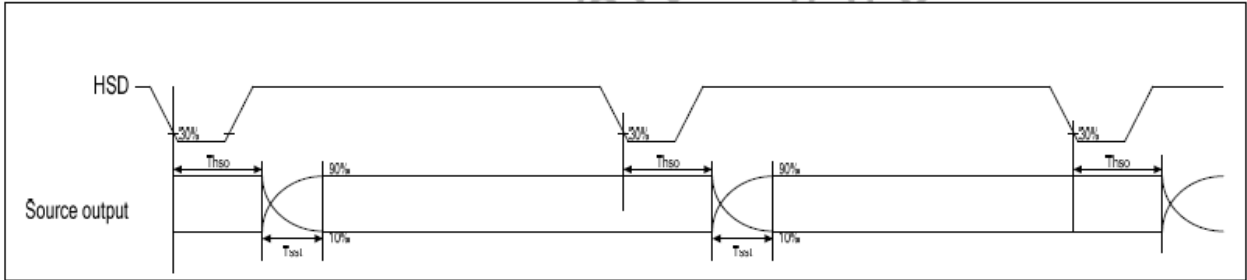

Figure 12. 2: Source Output Timing Diagram

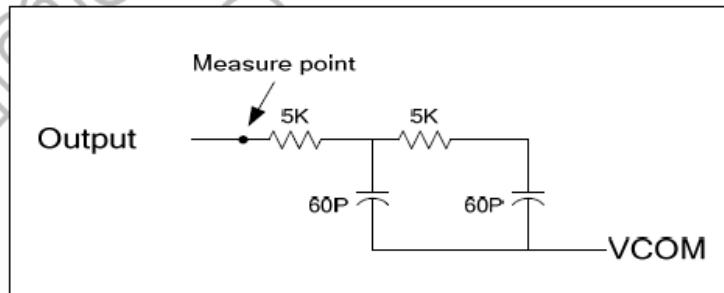
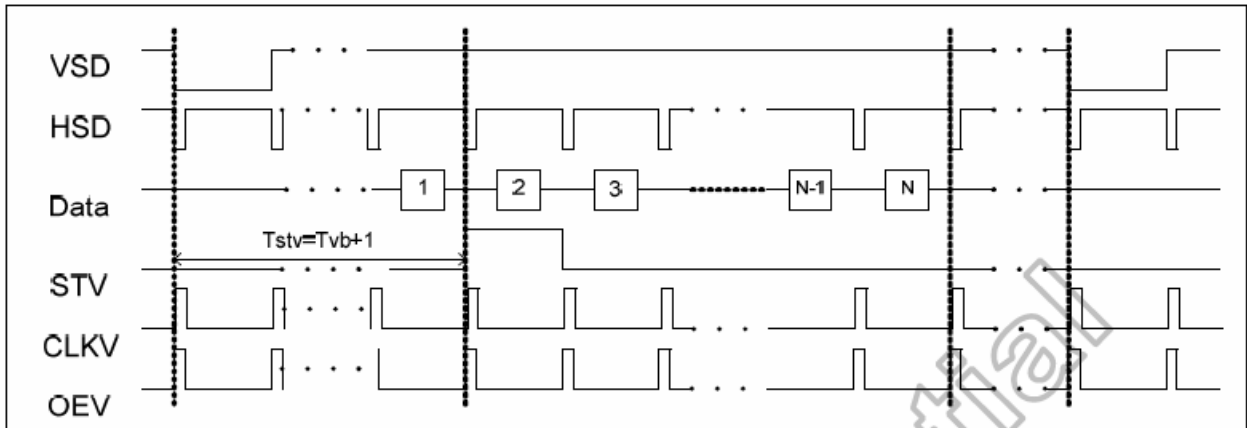
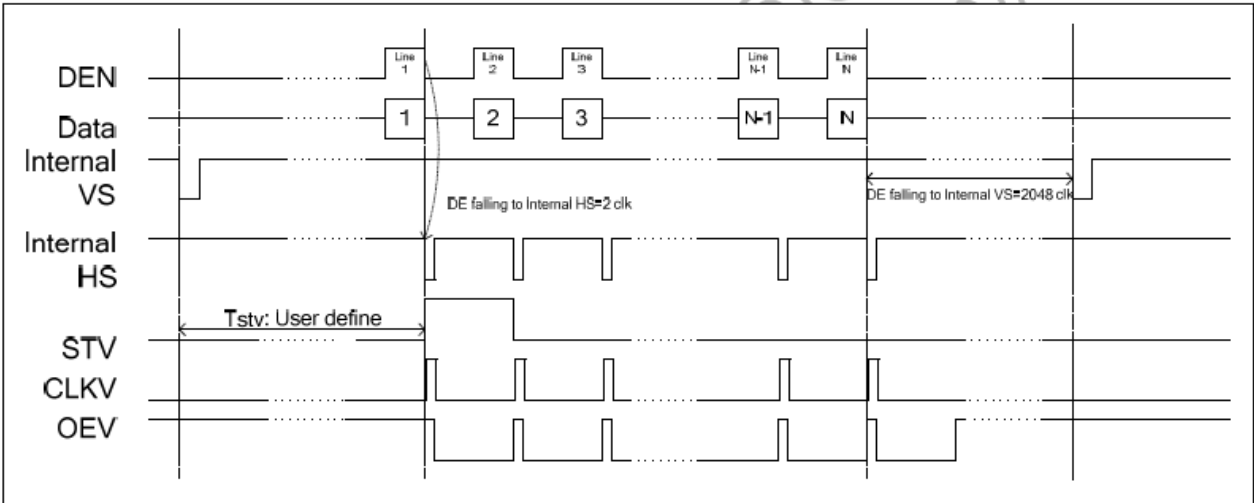

Figure 12. 3: Output Load Condition

### 6.3.2.3 Vertical timing diagram HV (Cascade)



### 6.3.2.4 Vertical timing diagram DE (Cascade)



### 6.3.2.5 Gate output timing diagram (Cascade)

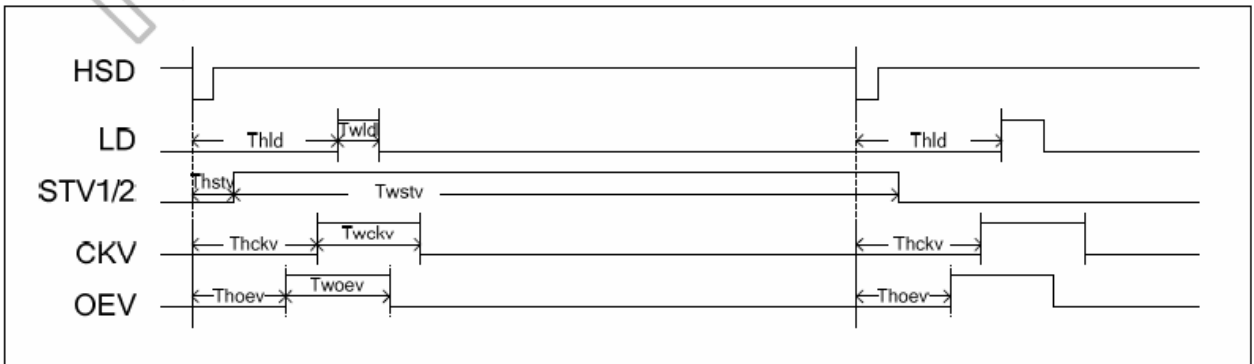

### 6.3.2.6 Vertical timing diagram HV (Dual gate)

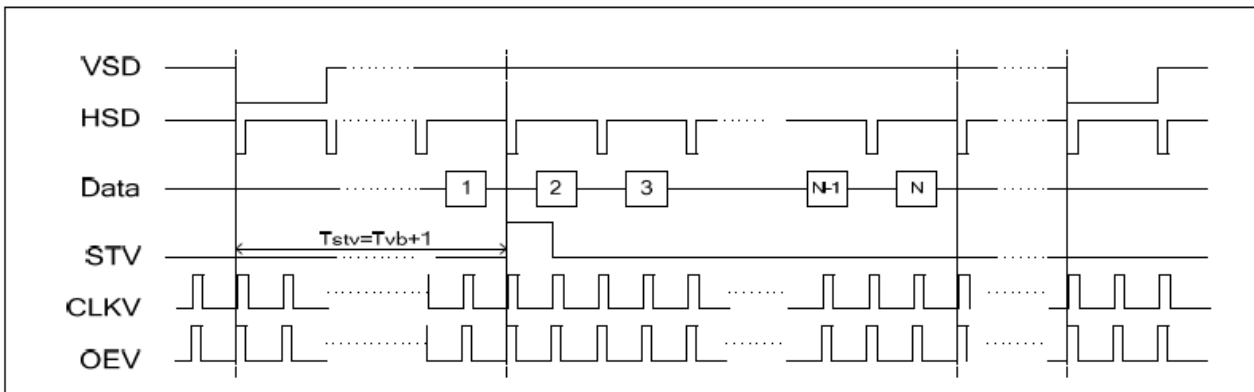

### 6.3.2.7 Vertical timing diagram DE (Dual gate)

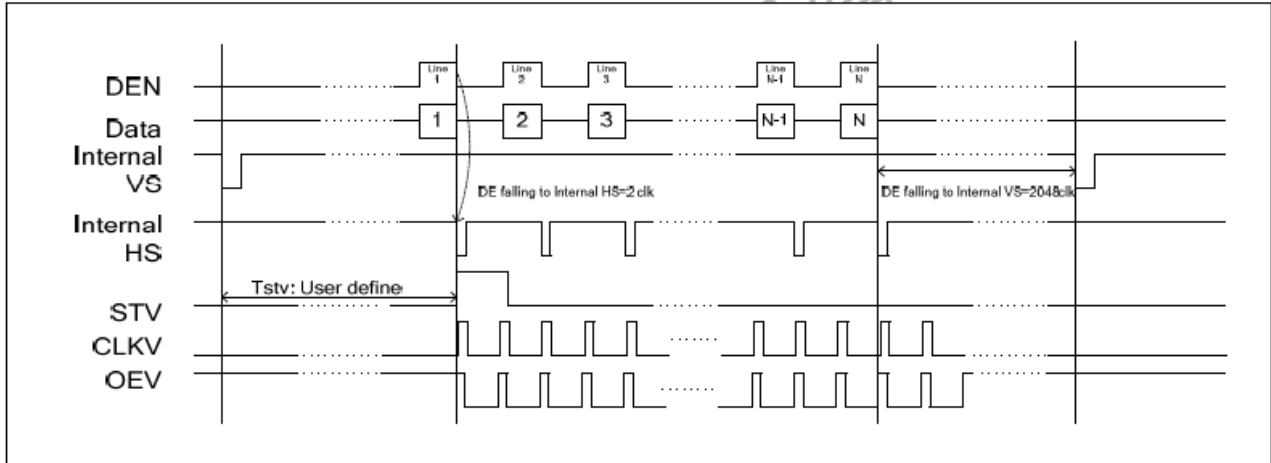

### 6.3.2.8 Gate output timing diagram (Dual gate)

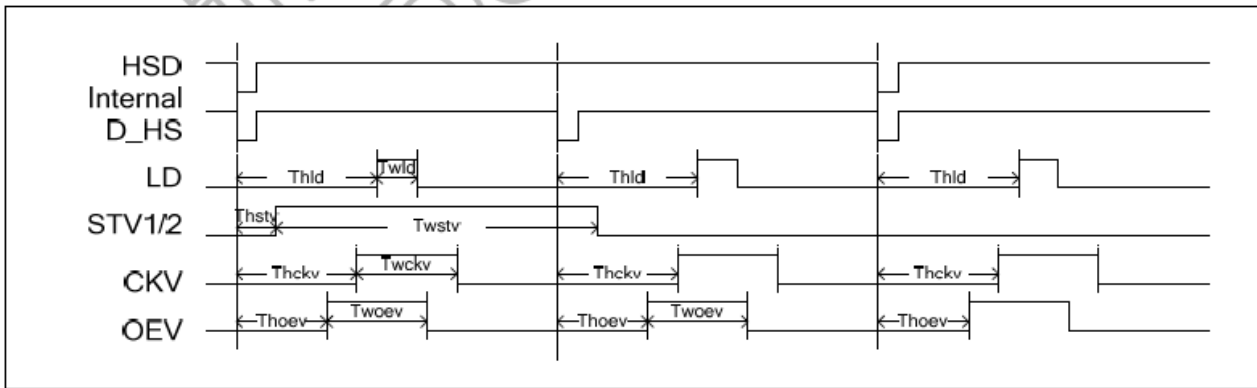

## 7. Optical Characteristics

Items	Symbol	Condition	Min.	Typ.	Max.	Unit	Remark	Note
Response time	Tr+Tf	-	-	30	40	ms	FIG.1	Note4
Contrast Ratio	CR		640	800	-	-	FIG.2	Note1
Surface luminance	LV	$\theta = 0^\circ$	450	500	-	cd/m2	FIG.2	Note2
Luminance uniformity	Yu	$\theta = 0^\circ$	-	-	-	%	FIG.2	Note3
NTSC	-	$\theta = 0^\circ$	45	50	-	%	FIG.2	Note5
Viewing angle	$\theta_T$	Center CR $\geq$ 10	70	80	-	deg	FIG.3	Note6
	$\theta_B$		70	80	-	deg	FIG.3	
	$\theta_L$		70	80	-	deg	FIG.3	
	$\theta_R$		70	80	-	deg	FIG.3	
Chromaticity	Red	R <sub>X</sub>	0.57	0.620	0.67	-	FIG.2 CIE1931	Note5
		R <sub>Y</sub>	0.278	0.328	0.378	-		
	Green	G <sub>X</sub>	0.284	0.334	0.384	-		
		G <sub>Y</sub>	0.494	0.544	0.594	-		
	Blue	B <sub>X</sub>	0.089	0.139	0.189	-		
		B <sub>Y</sub>	0.083	0.133	0.183	-		
	White	W <sub>X</sub>	0.2651	0.3151	0.3651	-		
		W <sub>Y</sub>	0.2764	0.3264	0.3764	-		

### Note1. Definition of contrast ratio

Contrast ratio (Cr) is defined mathematically by the following formula. For more information see FIG.2.

$$\text{Contrast ratio} = \frac{\text{Luminance measured when LCD on the "White" state}}{\text{Luminance measured when LCD on the "Black" state}}$$

For contrast ratio, Surface Luminance, Luminance uniformity and CIE, the testing data is based on TOPCON' s BM-5 or BM-7 photo detector or compatible.

### Note2. Definition of surface luminance

Surface luminance is the luminance with all pixels displaying white. For more information see FIG.2.

L<sub>v</sub> = Average Surface Luminance with all white pixels (P1,P2,P3, ....., Pn)

### Note3. Definition of luminance uniformity

The luminance uniformity in surface luminance is determined by measuring luminance at each test position 1 through n, and then dividing the maximum luminance of n points luminance by minimum luminance of n points luminance. For more information see FIG.2.

$$YU = \frac{\text{Minimum surface luminance with all white pixels (P1,P2,P3,.....,Pn)}}{\text{Maximum surface luminance with all white pixels (P1,P2,P3,.....,Pn)}}$$



**Note4. Definition of response time**

The response time is defined as the LCD optical switching time interval between “White” state and “Black” state. Rise time (Tr) is the time between photo detector output intensity changed from 90% to 10%. And fall time (Tf) is the time between photo detector output intensity changed from 10% to 90%.

For additional information see FIG1.

**Note5. Definition of color chromaticity (CIE1931)**

CIE (x, y) chromaticity, The x, y value is determined by screen active area center position P5. For more information see FIG.2.

**Note6. Definition of viewing angle**

Viewing angle is the angle at which the contrast ratio is greater than 10. Angles are determined for the horizontal or x axis and the vertical or y axis with respect to the z axis which is normal to the LCD surface. For more information see FIG.3.

For viewing angle and response time testing, the testing data is based on Autronic-Melchers’s ConoScope or DMS series Instruments or compatible.

**FIG.1. The definition of response Time**

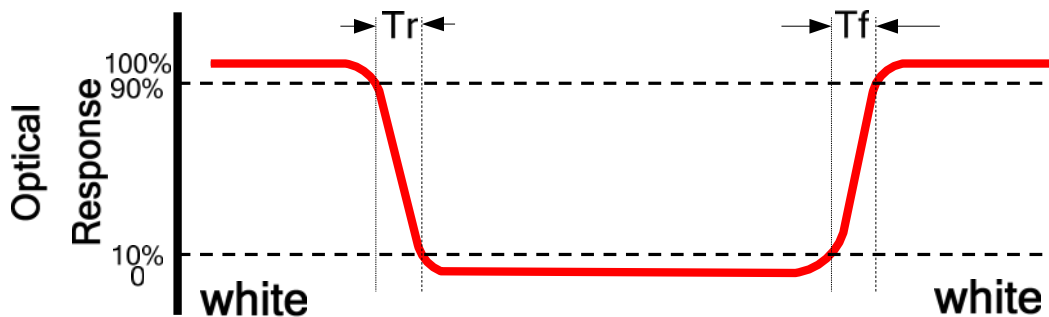

**FIG.2. Measuring method for contrast ratio, surface luminance, luminance uniformity, CIE (x, y) chromaticity**

Size: S≤5” (see Figure a) A : 5 mm B: 5 mm

H,V: Active area

Light spot size Ø=5mm (BM-5) or Ø=7.7mm (BM-7) 50cm distance or compatible distance from the LCD surface to detector lens.

Test spot position: see Figure a.

Measurement instrument: TOPCON’s luminance meter BM-5 or BM-7 or compatible (see Figure c).

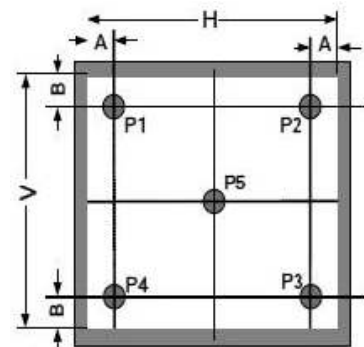

Figure a

Size: 5” < S ≤ 12.3” (see Figure b) H, V: Active area

Light spot size Ø=5mm (BM-5) or Ø=7.7mm (BM-7) 50cm distance or compatible distance from the LCD surface to detector lens.

Test spot position: see Figure b.

Measurement instrument : TOPCON's luminance meter BM-5 or BM-7 or compatible (see Figure c).

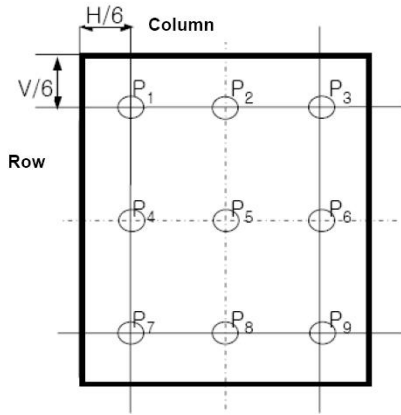

Figure b

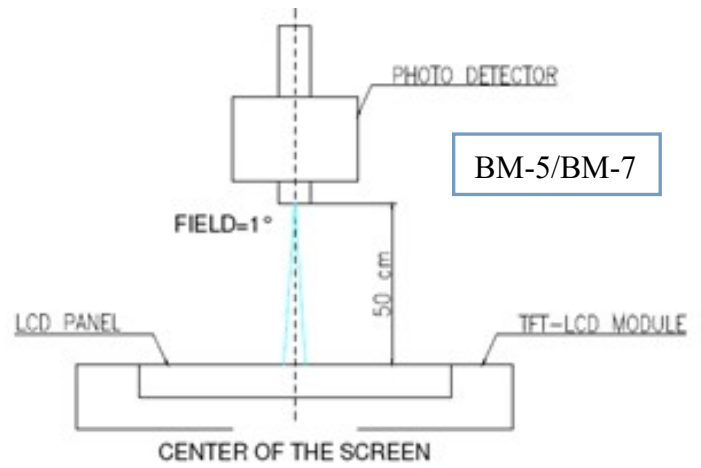
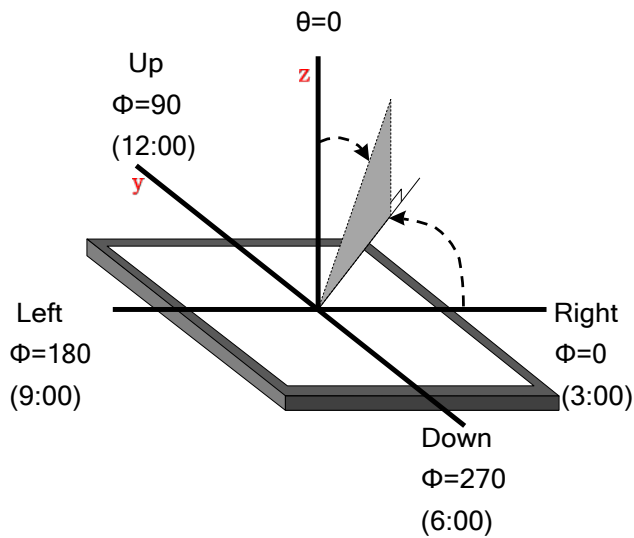

Figure c

FIG.3.The definition of viewing angle



## 8. Environmental / Reliability Tests

No	Test Item	Condition	Remarks
1	High Temperature Operation	Ts= +85°C, 96hrs	Note 1 IEC60068-2-2, GB2423.2-89
2	Low Temperature Operation	Ta= -30°C, 96hrs	Note 2 IEC60068-2-1 GB2423.1-89
3	High Temperature Storage	Ta= +85°C, 96hrs	IEC60068-2-2 GB2423.2-89
4	Low Temperature Storage	Ta= -30°C, 96hrs	IEC60068-2-1 GB/T2423.1-89
5	High Temperature & Humidity Storage	Ta= +60°C, 90% RH max,96 hours	IEC60068-2-3 GB/T2423.3-2006
6	Thermal Shock (Non-operation)	-20°C 30 min ~ +60°C 30 min Change time: 5min, 30 Cycle	Start with cold temperature, end with high temperature IEC60068-2-14, GB2423.22-87
7	Electro Static Discharge (Operation)	C=150pF, R=330 Ω, 5 points/panel Air:±8KV, 5 times; Contact: ±4KV, 5 times; (Environment: 15°C ~ 35°C, 30% ~ 60%, 86Kpa ~ 106Kpa)	IEC61000-4-2 GB/T17626.2-1998
8	Vibration (Non-operation)	Frequency range: 10~55Hz, Stroke: 1mm Sweep: 1Hz~55Hz~3.5Hz 2 hours for each direction of X .Y. Z. (package condition)	IEC60068-2-6 GB/T2423.5-1995
9	Shock (Non-operation)	60G 6ms, ± X, ±Y , ± Z 3 times for each direction	IEC60068-2-27 GB/T2423.5-1995
10	Package Drop Test	Height: 80 cm, 1 corner, 3 edges, 6 surfaces	IEC60068-2-32 GB/T2423.8-1995

- Note:
1. Ts is the temperature of panel's surface.
  2. Ta is the ambient temperature of sample.
  3. The size of sample is 5pcs.

# 9. Mechanical Drawing

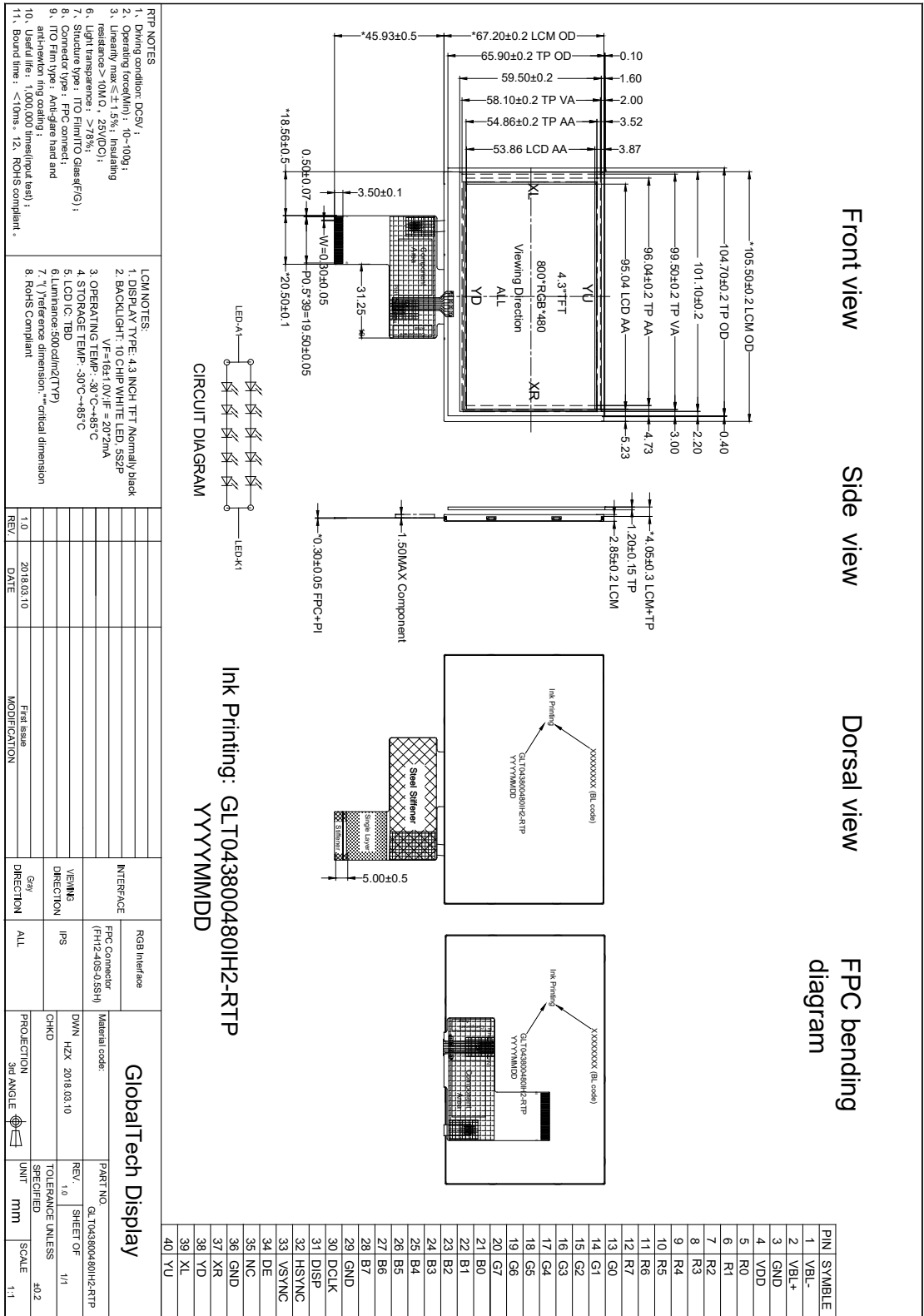

# 10. Packing

## Packing Method

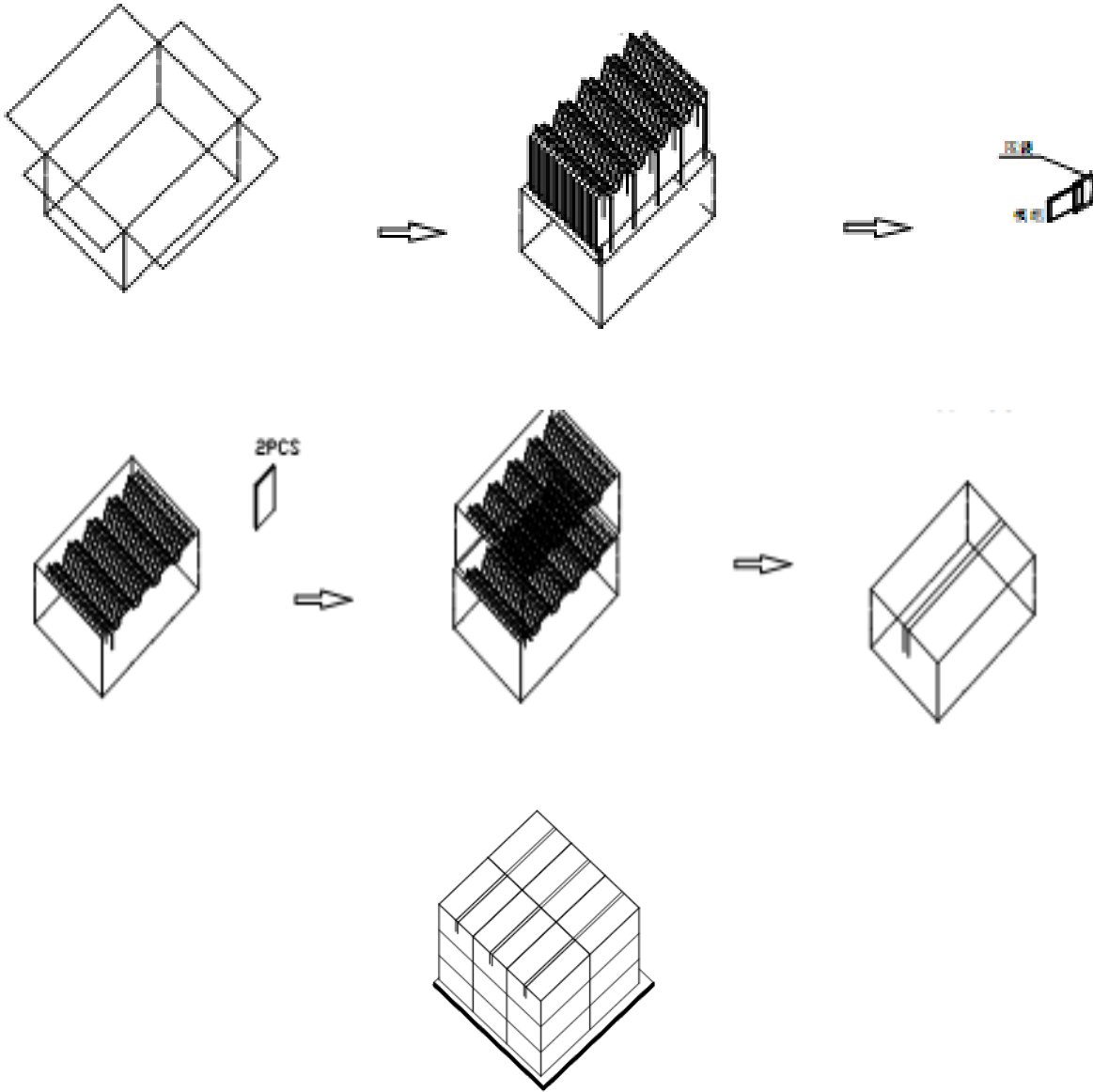

## **11. TFT-LCD Module Inspection Criteria**

### **11.1 Scope**

The incoming inspection standards shall be applied to TFT-LCD Modules (hereinafter called "Modules") that supplied by GlobalTech Display.

### **11.2 Incoming Inspection**

The customer shall inspect the modules within twenty calendar days of the delivery date (the inspection period) at its own cost. The result of the inspection (acceptance or rejection) shall be recorded in writing, and a copy of this writing will be promptly sent to the seller, If the results of the inspecting from buyer does not send to the seller within twenty calendar days of the delivery date. The modules shall be regards as acceptance. Should the customer fail to notify the seller within the inspection period, the buyer's right to reject the modules shall be lapsed and the modules shall be deemed to have been accepted by the buyer.

### **11.3 Inspection Sampling**

11.3.1. Lot size: Quantity per shipment lot per model

11.3.2. Sampling type: Normal inspection, Single sampling

11.3.3. Inspection level: II

11.3.4. Sampling table: MIL-STD-105E

11.3.5. Acceptable quality level (AQL). Major defect: AQL=0.65 Minor defect: AQL=1.00

### **11.4 Inspection Conditions**

11.4.1 Ambient conditions:

a. Temperature: Room temperature  $25 \pm 5^{\circ}\text{C}$

b. Humidity:  $(60 \pm 10) \%RH$

c. Illumination: Single fluorescent lamp non-directive (300 to 700 Lux)

11.4.2 Viewing distance

The distance between the LCD and the inspector's eyes shall be at least  $35 \pm 5\text{cm}$ .

11.4.3 Viewing Angle

U/D:  $45^{\circ} / 45^{\circ}$  , L/R:  $45^{\circ} / 45^{\circ}$

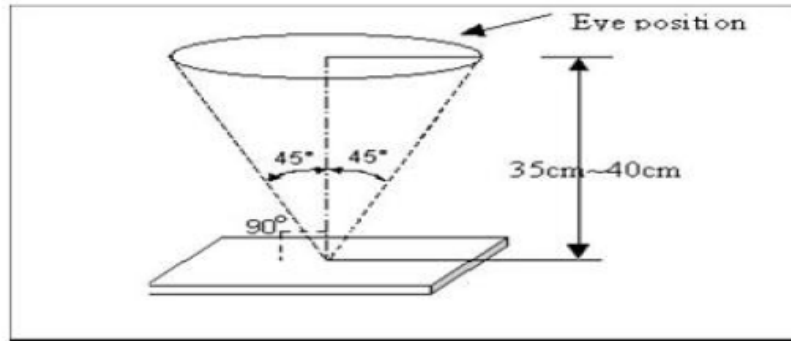

## 11.5 Inspection Criteria

Defects are classified as major defects and minor defects according to the degree of Defectiveness defined herein.

### 11.5.1 Major defect

Item No	Items to be inspected	Inspection Standard
5.1.1	All functional defects	1) No display 2) Display abnormally 3) Short circuit 4) line defect
5.1.2	Missing	Missing function component
5.1.3	Crack	Glass Crack

### 11.5.2 Minor defect

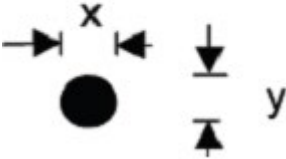
Item No	Items to be inspected	Inspection standard	
5.2.1	Spot Defect Including Black spot White spot Pinhole Foreign particle Polarizer dirt	For dark/white spot is defined $\varphi = (x+y) / 2$ 	
		Size $\varphi$ (mm)	Acceptable Quantity
		$\varphi \leq 0.2$	Ignore
		$0.2 < \varphi \leq 0.5$	3

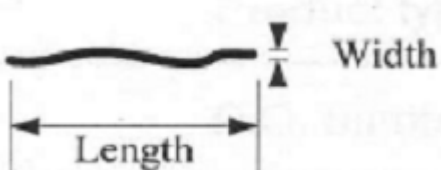
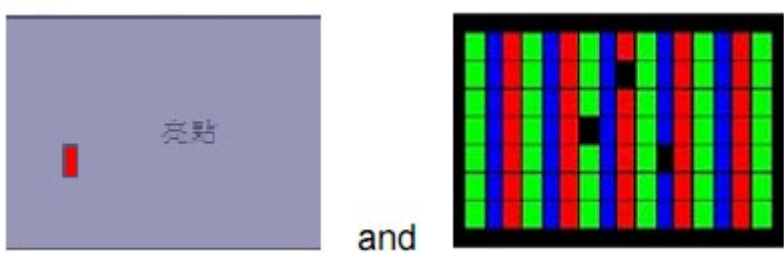
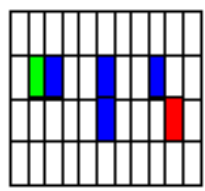
		$0.5 < \phi$	Not allowed	
5.2.2	Line Defect Including Black line White line Scratch	Define: 		
		Width(mm) Length(mm)	Acceptable Quantity	
		$W \leq 0.05$	Ignore	
		$0.05 < W \leq 0.1$ $L \leq 2.5$	3	
		$0.1 < W$ , or $L > 2.5$	Not allowed	
5.2.3	Polarizer Dent/Bubble	Size $\phi$ (mm)	Acceptable Quantity	
		$\phi \leq 0.2$	Ignore	
		$0.2 < \phi \leq 0.3$	2	
		$0.3 < \phi \leq 0.5$	1	
		$0.5 < \phi$	Not allowed	
		Total QTY	3	
5.2.4	Electrical Dot Defect	Bright and Black dot define: 		
		 Two Adjacent Dot		
		Inspection pattern: Full white, Full black, Red, green and blue screens		
		Item	Acceptable Quantity	
			I	O
Black dot defect	2		(5mm $\leq$ Distance)	
Bright dot defect	1			

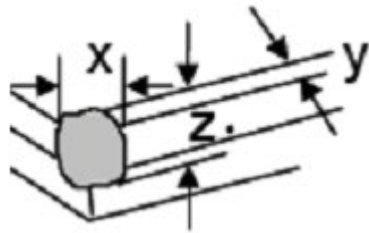
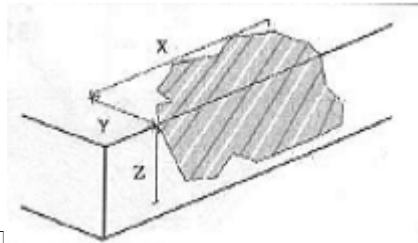

		<b>Two Adjacent Dot</b>	<b>1</b>	
		<b>There or more Adjacent Dot</b>	<b>Not allowed</b>	
		<b>Total Dot</b>	<b>2</b>	
<b>5.2.5</b>	<b>Glass defect</b>	 <p><b>1. Corner Fragment:</b></p>		
		<b>Size(mm)</b>		<b>Acceptable Quantity</b> <input type="checkbox"/>
		$X \leq 3\text{mm}$ $Y \leq 1\text{mm}$ $Z \leq T$		<b>Ignore</b> <b>T: Glass thickness</b> <b>X: Length</b> <b>Y: Width</b> <b>Z: thickness</b>
		 <p><b>2. Side Fragment:</b> <input type="checkbox"/></p>		
		<b>Size(mm)</b>		<b>Acceptable Quantity</b>
		$X \leq 5.0\text{mm}$ $Y \leq 1\text{mm}$ $Z \leq T$		<b>T: Glass thickness</b> <b>X: Length</b> <b>Y: Width</b> <b>Z: thickness</b>

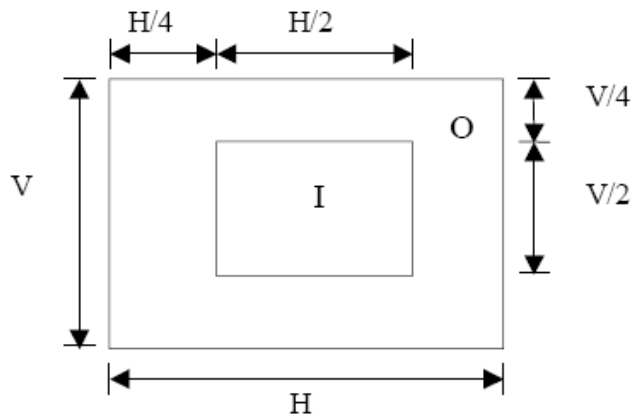

I area & O area

- Note:
- 1). Dot defect is defined as the defective area of the dot area is larger than 50% of the dot area.
  - 2). The distance between two bright dot defects (red, green, blue, and white) should be larger than 15mm.
  - 3). The distance between black dot defects or black and bright dot defects should be more than 5mm apart.
  - 4). Polarizer bubble is defined as the bubble appears on active display area. The defect of polarizer bubble shall be ignored if the polarizer bubble appears on the outside of active display area.

## 11.6 Mechanics specification

As for the outside dimension, weight of the modules, please refer to product specification  
For more details

## 12. Precautions for Use of LCD modules

### 12.1 Handling Precautions

12.1.1. The display panel is made of glass. Do not subject it to a mechanical shock by dropping it from a high place, etc.

12.1.2. If the display panel is damaged and the liquid crystal substance inside it leaks out, be sure not to get any in your mouth, if the substance comes into contact with your skin or clothes, promptly wash it off using soap and water.

12.1.3. Do not apply excessive force to the display surface or the adjoining areas since this may cause the color tone to vary.

12.1.4. The polarizer covering the display surface of the LCD module is soft and easily scratched. Handle this polarizer carefully.

12.1.5. If the display surface is contaminated, breathe on the surface and gently wipe it with a soft dry cloth. If still not completely clear, moisten cloth with one of the following solvents:

- Isopropyl alcohol
- Ethyl alcohol

Solvents other than those mentioned above may damage the polarizer. Especially, do not use the following:

- Water
- Ketene
- Aromatic solvents

12.1.6. Do not attempt to disassemble the LCD Module.

12.1.7. If the logic circuit power is off, do not apply the input signals.

12.1.8. To prevent destruction of the elements by static electricity, be careful to maintain an optimum work environment.

12.1.8.1. Be sure to ground the body when handling the LCD Modules.

12.1.8.2. Tools required for assembly, such as soldering irons, must be properly ground.

12.1.8.3. To reduce the amount of static electricity generated, do not conduct assembly and other work under dry conditions.

12.1.8.4. The LCD Module is coated with a film to protect the display surface. Be care when peeling off this protective film since static electricity may be generated.

## **12.2 Storage Precautions**

12.2.1. When storing the LCD modules, avoid exposure to direct sunlight or to the light of fluorescent lamps.

12.2.2. The LCD modules should be stored under the storage temperature range. If the LCD modules will be stored for a long time, the recommend condition is:

Temperature: 0°C ~ 40°C

Relatively humidity: ≤80%

12.2.3. The LCD modules should be stored in the room without acid, alkali and harmful gas.

## **12.3 Transportation Precautions**

The LCD modules should be no falling and violent shocking during transportation, and also should avoid excessive press, water, damp and sunshine.