

PREMIUM TABLE-MACHINED CONTACT:

TYCO P/N	REF. AUGAT P/N	POSITION	DIM. A	DIM. B	DIM. C	PLATING	CONTACT
0-1437542-6	706-AG1D	6	2	.200	.300	NOTE 2	STANDARD PC LEAD
0-1437542-7	706-AG2D	6	2	.200	.300	NOTE 3	STANDARD PC LEAD
7-1437542-7	708-AG10D	8	3	.300	.300	NOTE 7	LOW PROFILE
1-1437542-0	708-AG1D	8	3	.300	.300	NOTE 2	STANDARD PC LEAD
9-1437532-1	708-AG20D	8	3	.300	.300	NOTE 5	LOW PROFILE
1-1437542-1	708-AG2D	8	3	.300	.300	NOTE 3	STANDARD PC LEAD
1-1437542-3	714-AG1D	14	6	.600	.300	NOTE 2	STANDARD PC LEAD
1-1437542-4	714-AG20D	14	6	.600	.300	NOTE 5	LOW PROFILE
0-1437541-1	714-AG2D	14	6	.600	.300	NOTE 3	STANDARD PC LEAD
1-1437542-7	716-AG1D	16	7	.700	.300	NOTE 2	STANDARD PC LEAD
7-1437542-5	716-AG20D	16	7	.700	.300	NOTE 5	LOW PROFILE
1-1437542-9	716-AG2D	16	7	.700	.300	NOTE 3	STANDARD PC LEAD
2-1437542-2	718-AG1D	18	8	.800	.300	NOTE 2	STANDARD PC LEAD
2-1437542-4	718-AG2D	18	8	.800	.300	NOTE 3	STANDARD PC LEAD
7-1437542-8	718-AG20D	18	8	.800	.300	NOTE 5	LOW PROFILE
2-1437542-7	720-AG1D	20	9	.900	.300	NOTE 2	STANDARD PC LEAD
2-1437542-8	720-AG20D	20	9	.900	.300	NOTE 5	LOW PROFILE
2-1437542-9	720-AG2D	20	9	.900	.300	NOTE 3	STANDARD PC LEAD
3-1437542-2	722-AG1D	22	10	1.000	.400	NOTE 2	STANDARD PC LEAD
3-1437542-3	722-AG21D	22	10	1.000	.300	NOTE 2	STANDARD PC LEAD
3-1437542-4	722-AG22D	22	10	1.000	.300	NOTE 3	STANDARD PC LEAD
3-1437542-5	722-AG2D	22	10	1.000	.400	NOTE 3	STANDARD PC LEAD
3-1437542-7	724-AG10D	24	11	1.100	.300	NOTE 7	LOW PROFILE
3-1437542-8	724-AG1D	24	11	1.100	.300	NOTE 2	STANDARD PC LEAD
3-1437542-9	724-AG20D	24	11	1.100	.300	NOTE 5	LOW PROFILE
4-1437542-1	724-AG21D	24	11	1.100	.400	NOTE 2	STANDARD PC LEAD
4-1437542-3	724-AG2D	24	11	1.100	.300	NOTE 3	STANDARD PC LEAD
7-1437542-0	724-AG30D	24	11	1.100	.600	NOTE 7	LOW PROFILE
4-1437542-5	724-AG3D	24	11	1.100	.600	NOTE 2	STANDARD PC CARD
7-1437542-1	724-AG40D	24	11	1.100	.600	NOTE 5	LOW PROFILE
5-1447099-0	724-AG420D	24	11	1.100	.400	NOTE 5	LOW PROFILE
4-1437542-6	724-AG4D	24	11	1.100	.600	NOTE 3	STANDARD PC LEAD
5-1447099-1	728-AG20D	28	13	1.300	.600	NOTE 5	LOW PROFILE
5-1437542-0	728-AG30D	28	13	1.300	.600	NOTE 7	LOW PROFILE
5-1437542-1	728-AG3D	28	13	1.300	.600	NOTE 2	STANDARD PC LEAD
5-1437542-2	728-AG40D	28	13	1.300	.600	NOTE 5	LOW PROFILE
5-1437542-3	728-AG4D	28	13	1.300	.600	NOTE 3	STANDARD PC LEAD
5-1447099-7	730-AG1D	30	14	1.400	.600	NOTE 2	STANDARD PC LEAD
5-1437542-7	732-AG3D	32	15	1.500	.600	NOTE 2	STANDARD PC LEAD
0-1437533-5	732-AG40D	32	15	1.500	.600	NOTE 5	LOW PROFILE
5-1437542-8	732-AG4D	32	15	1.500	.600	NOTE 3	STANDARD PC LEAD
6-1437542-7	736-AG3D	36	17	1.700	.600	NOTE 2	STANDARD PC LEAD
0-1437533-6	736-AG4D	36	17	1.700	.600	NOTE 3	STANDARD PC LEAD
6-1447099-5	740-AG30D	40	19	1.900	.600	NOTE 7	LOW PROFILE
6-1437542-1	740-AG3D	40	19	1.900	.600	NOTE 2	STANDARD PC LEAD
6-1437542-2	740-AG40D	40	19	1.900	.600	NOTE 5	LOW PROFILE
6-1437542-4	740-AG4D	40	19	1.900	.600	NOTE 3	STANDARD PC LEAD

SUPERSEDED BY LOOSE CONTACT ASSY. 2-1437510-1

SUPERSEDED BY LOOSE CONTACT ASSY. 5-1437509-7

SUPERSEDED BY LOOSE CONTACT ASSY. 5-1437509-8

SUPERSEDED BY LOOSE CONTACT ASSY. 5-1437509-7

SUPERSEDED BY LOOSE CONTACT ASSY. 2-1437510-1

SUPERSEDED BY LOOSE CONTACT ASSY. 2-1437510-2

SUPERSEDED BY LOOSE CONTACT ASSY. 2-1437510-2

SUPERSEDED BY LOOSE CONTACT ASSY. 5-1437509-7

NOTES:

- MATERIAL - CARRIER: ALUMINUM ALLOY; CONTACT: BERYLLIUM COPPER; SLEEVE: BRASS ALLOY
- PLATING - 7XX-AG1D/3D/21D (MACH CONT) OR 7XX-AG1D/3D/21D-ES (STAMPED CONTACT) : 20 UIN MIN. GOLD OVER 30 UIN MIN. NICKEL ON INNER CONTACT; 7.5 UIN MIN. GOLD OVER 50 UIN MIN. NICKEL ON SLEEVE.
- PLATING - 7XX-AG2D/4D/22D (MACH CONT) OR 7XX-AG2D/4D/22D-ES (STAMP CONT.) : 20 UIN MIN. GOLD OVER 30 UIN MIN. NICKEL ON INNER CONTACT; 80 UIN MIN. TIN-LEAD OVER 50 UIN. COPPER ON SLEEVE.
- PLATING - 7XX-AG2D/4D/22D-ESL (STAMP CONT) 5 UIN MIN. GOLD OVER 50 UIN MIN. NICKEL ON CONTACT; 80 UIN MIN. TIN-LEAD OVER 50 UIN MIN. COPPER ON SLEEVE.
- PLATING - 7XX-AG20D/40D/320D/420D (MACH CONT) OR 7XX-AG20D/40D/320D/420D-ES (STAMPED CONTACT) : 20 UIN MIN. GOLD OVER 30 UIN MIN. NICKEL ON INNER CONTACT; 180 UIN MIN TIN-LEAD OVER 50 UIN MIN. COPPER ON SLEEVE
- PLATING - 7XX-AG20D/40D/320D/420D-ESL (STAMPED CONTACT) : 5 UIN MIN. GOLD OVER 50 UIN MIN. NICKEL ON CONTACT; 180 UIN MIN. TIN-LEAD OVER 50 UIN. COPPER ON SLEEVE.
- PLATING - 7XX-AG10D/30D/310D/410D (MACHINED CONTACT) OR 7XX-AG10D/30D/310D/410D-ES (STAMPED CONTACT) : 20 UIN MIN. GOLD OVER 30 UIN MIN. NICKEL ON INNER CONTACT; 20 UIN MIN. GOLD OVER 50 UIN MIN. NICKEL ON SLEEVE.
- PLATING - 7XX-AG14D (MACHINED CONTACT) : 80 UIN MIN. TIN-LEAD OVER 75 UIN MIN. COPPER ON CONTACT; 80 UIN MIN. TIN-LEAD OVER 50 UIN COPPER ON SLEEVE
- MATING IC PIN : .016 TO .021 DIAMETER, .105 MIN. LENGTH
- PCB HOLE SIZE RANGE .035±.003 (STD. PC LEAD) AND .055±.001 (LOW PROFILE MOUNT).
- NOT RECOMMENDED FOR PCB THICKNESS GREATER THAN .093.

REPLACEMENT SOCKET CONTACT ASSEMBLY

STANDARD PC LEAD	REF. AUGAT P/N	LOW PROFILE MOUNT	PLATING SCHEME
5-1437509-7	LSG-1AG14-1	--	GOLD CONTACT/GOLD SLEEVE
5-1437509-8	LSG-1AG14-14	--	GOLD CONTACT/TIN-LEAD SLEEVE
--	LSG-1DG17-1	2-1437510-1	GOLD CONTACT/GOLD SLEEVE
--	LSG-1DG17-14	2-1437510-2	GOLD CONTACT/TIN-LEAD SLEEVE

THIS DRAWING IS A CONTROLLED DOCUMENT.		DWN BSV	14OCT04	Tyco Electronics Corporation Harrisburg, Pa 17105-3808	
DIMENSIONS: INCHES		TOLERANCES UNLESS OTHERWISE SPECIFIED:		Tyco Electronics Corporation Harrisburg, Pa 17105-3808	
		0 PLC ± -	1 PLC ± -	2 PLC ± .01	3 PLC ± .002
MATERIAL SEE NOTE 1		4 PLC ± .0005	ANGLES ± 1/2	700 SERIES AUGAT DIP SOCKETS, DISPOSABLE CARRIER	
CUSTOMER DRAWING		FINISH -	APVD -	SIZE A1	CAGE CODE 00779
		DRAWING NO 1437542		RESTRICTED TO -	
		SCALE 1:1		SHEET 1 OF 3	
				REV 0	

ECONOMY TABLE - STAMPED CONTACT:

TYCO P/N	REF. AUGAT P/N	POSITION	DIM. A	DIM. B	DIM. C	PLATING	CONTACT	
0-1437542-8	706-AG2D-ES	6	2	.200	.300	NOTE 3	STANDARD PC LEAD	SUPERSEDED BY 1437542-7
0-1437542-9	706-AG2D-ESL	6	2	.200	.300	NOTE 4	STANDARD PC LEAD	SUPERSEDED BY 1437542-7
1-1437542-2	708-AG2D-ES	8	3	.300	.300	NOTE 3	STANDARD PC LEAD	SUPERSEDED BY 1-1437542-1
7-1437542-4	708-AG2D-ESL	8	3	.300	.300	NOTE 4	STANDARD PC LEAD	SUPERSEDED BY 1-1437542-1
1-1437542-5	714-AG2D-ES	14	6	.600	.300	NOTE 3	STANDARD PC LEAD	SUPERSEDED BY 1437541-1
1-1437542-6	714-AG2D-ESL	14	6	.600	.300	NOTE 4	STANDARD PC LEAD	SUPERSEDED BY 1437541-1
1-1437542-8	716-AG20D-ES	16	7	.700	.300	NOTE 5	LOW PROFILE	SUPERSEDED BY 7-1437542-5
2-1437542-0	716-AG2D-ES	16	7	.700	.300	NOTE 3	STANDARD PC LEAD	SUPERSEDED BY 1-1437542-9
7-1437542-6	716-AG2D-ESL	16	7	.700	.300	NOTE 4	STANDARD PC LEAD	SUPERSEDED BY 1-1437542-9
2-1437542-3	718-AG20D-ESL	18	8	.800	.300	NOTE 6	LOW PROFILE	SUPERSEDED BY 7-1437542-8
2-1437542-5	718-AG2D-ES	18	8	.800	.300	NOTE 3	STANDARD PC LEAD	SUPERSEDED BY 2-1437542-4
2-1437542-6	718-AG2D-ESL	18	8	.800	.300	NOTE 4	STANDARD PC LEAD	SUPERSEDED BY 2-1437542-4
3-1437542-0	720-AG2D-ES	20	9	.900	.300	NOTE 3	STANDARD PC LEAD	SUPERSEDED BY 2-1437542-9
3-1437542-1	720-AG2D-ESL	20	9	.900	.300	NOTE 4	STANDARD PC LEAD	SUPERSEDED BY 2-1437542-9
3-1437542-6	722-AG2D-ES	22	10	1.000	.400	NOTE 3	STANDARD PC LEAD	SUPERSEDED BY LOOSE CONTACT ASSY. 5-1437509-8
7-1437542-2	722-AG2D-ESL	22	10	1.000	.400	NOTE 4	STANDARD PC LEAD	SUPERSEDED BY LOOSE CONTACT ASSY. 5-1437509-8
4-1437542-0	724-AG20D-ES	24	11	1.100	.300	NOTE 5	LOW PROFILE	SUPERSEDED BY 3-1437542-9
4-1437542-2	724-AG22D-ES	24	11	1.100	.400	NOTE 3	STANDARD PC LEAD	SUPERSEDED BY LOOSE CONTACT ASSY. 5-1437509-8
4-1437542-4	724-AG2D-ES	24	11	1.100	.300	NOTE 3	STANDARD PC LEAD	SUPERSEDED BY 4-1437542-3
4-1437542-7	724-AG4D-ES	24	11	1.100	.600	NOTE 3	STANDARD PC LEAD	SUPERSEDED BY 4-1437542-6
4-1437542-8	724-AG4D-ESL	24	11	1.100	.600	NOTE 4	STANDARD PC LEAD	SUPERSEDED BY 4-1437542-6
5-1437542-4	728-AG4D-ES	28	13	1.300	.600	NOTE 3	STANDARD PC LEAD	SUPERSEDED BY 5-1437542-3
5-1437542-5	728-AG4D-ESL	28	13	1.300	.600	NOTE 4	STANDARD PC LEAD	SUPERSEDED BY 5-1437542-3
6-1447099-2	732-AG40D-ES	32	15	1.500	.600	NOTE 5	LOW PROFILE	SUPERSEDED BY 1437533-5
5-1437542-9	732-AG4D-ES	32	15	1.500	.600	NOTE 3	STANDARD PC LEAD	SUPERSEDED BY 5-1437542-8
6-1437542-0	732-AG4D-ESL	32	15	1.500	.600	NOTE 4	STANDARD PC LEAD	SUPERSEDED BY 5-1437542-8
6-1437542-3	740-AG40D-ES	40	19	1.900	.600	NOTE 5	LOW PROFILE	SUPERSEDED BY 6-1437542-2
6-1437542-5	740-AG4D-ES	40	19	1.900	.600	NOTE 3	STANDARD PC LEAD	SUPERSEDED BY 6-1437542-4
6-1437542-8	740-AG4D-ESL	40	19	1.900	.600	NOTE 4	STANDARD PC LEAD	SUPERSEDED BY 6-1437542-4

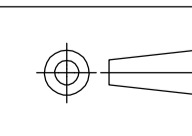
THIS DRAWING IS A CONTROLLED DOCUMENT.		DWN BSV	040CT04	tyco Electronics	Tyco Electronics Corporation Harrisburg, Pa 17105-3808
DIMENSIONS: INCHES		CHK K.WRIGHT	APVD -		NAME CARRIER ASS'Y. LEAD SOCKET
TOLERANCES UNLESS OTHERWISE SPECIFIED:		PRODUCT SPEC		APPLICATION SPEC	
		0 PLC ± - 1 PLC ± - 2 PLC ± .01 3 PLC ± .002 4 PLC ± .0005 ANGLES ± 1/2°		SIZE A1	
MATERIAL SEE NOTE 1		WEIGHT -		CAGE CODE 00779	DRAWING NO 1437542
CUSTOMER DRAWING		SCALE 1:1		SHEET 2 OF 3	REV 0

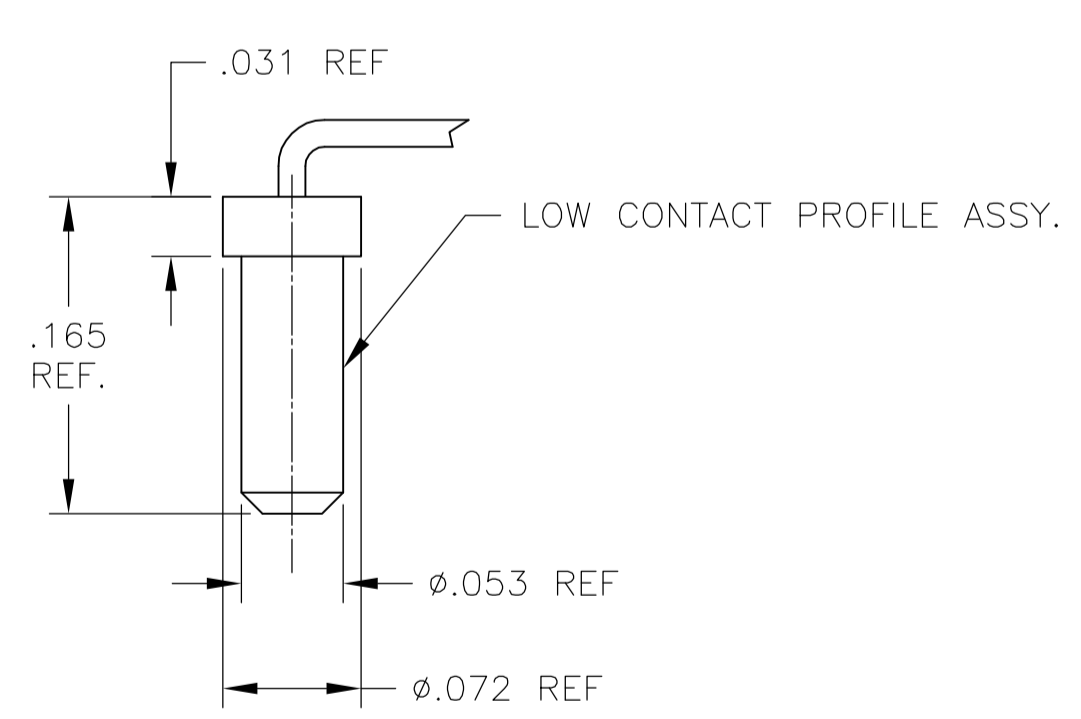
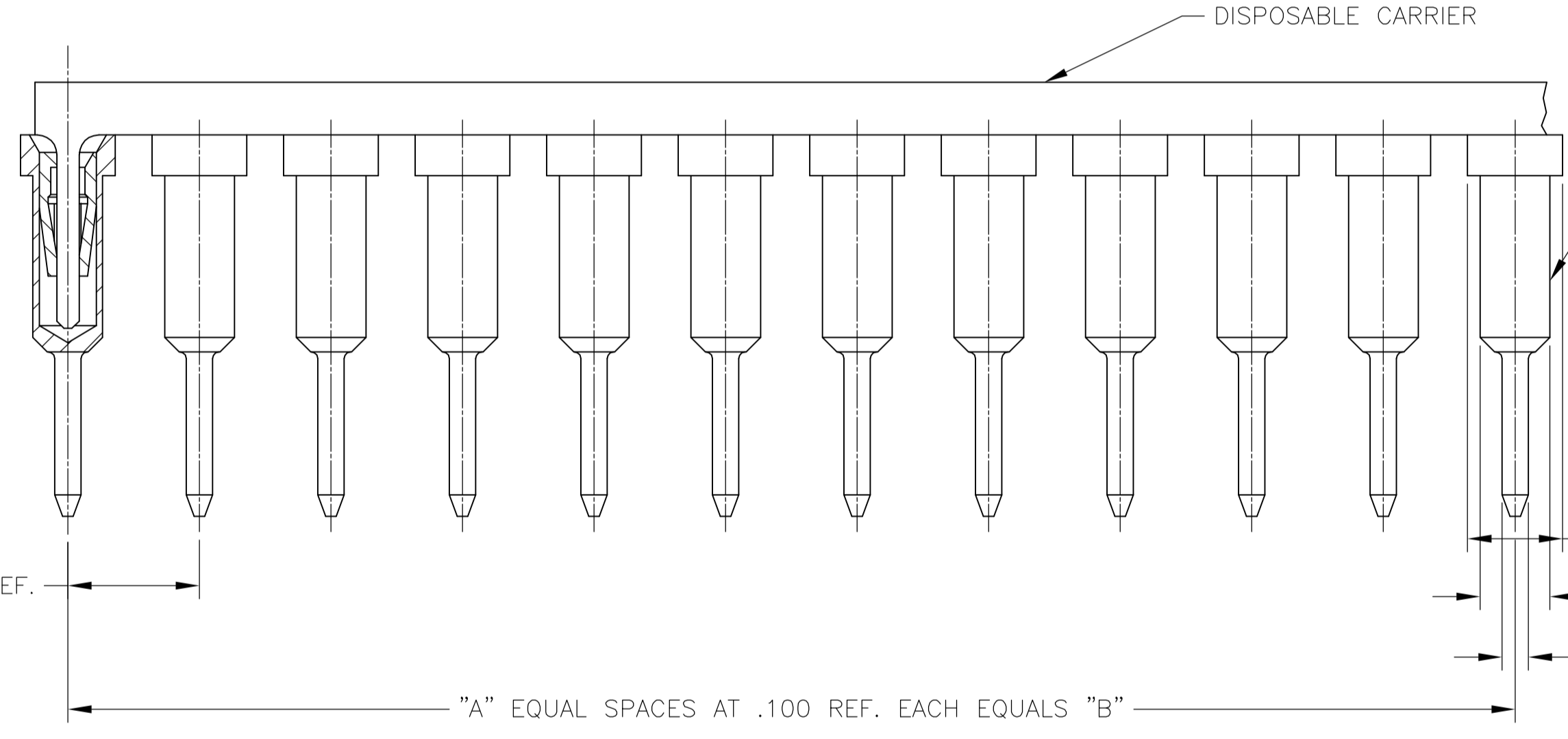
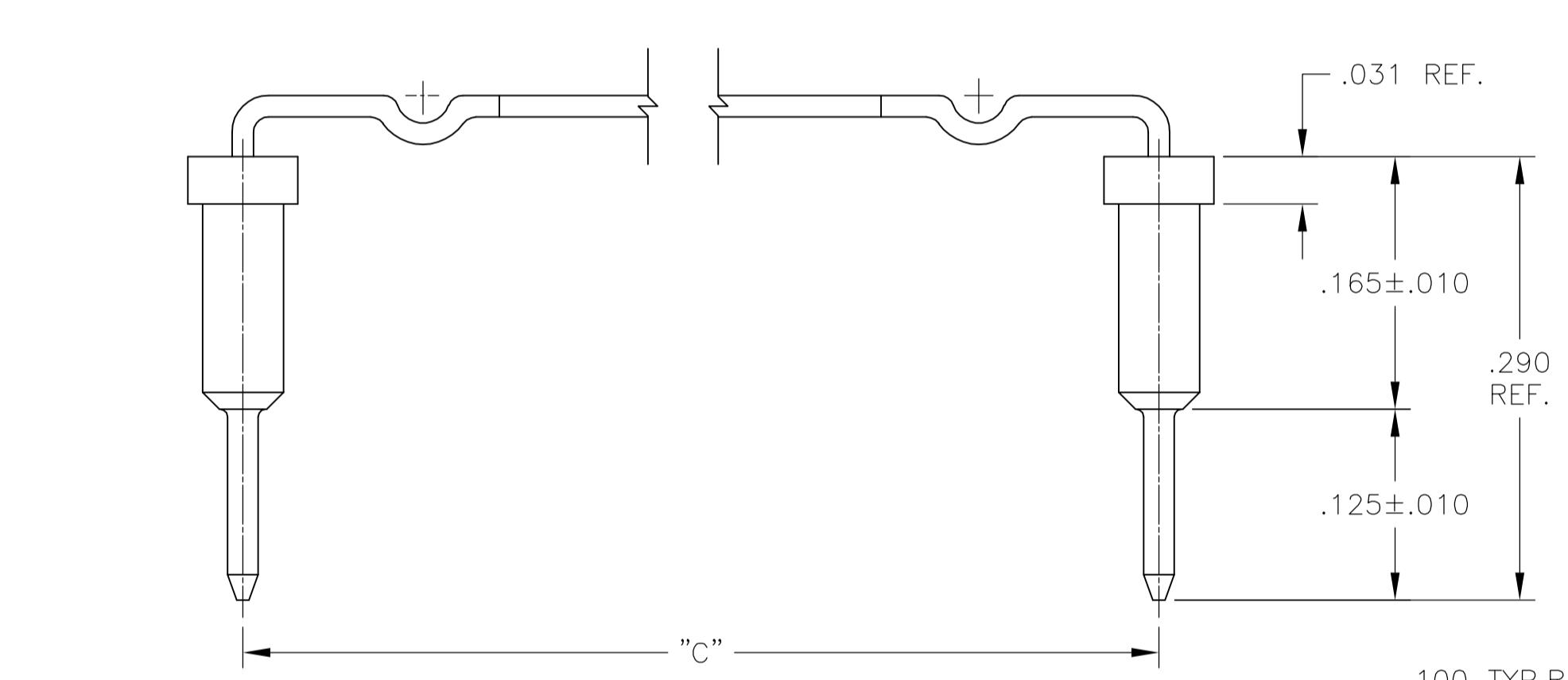
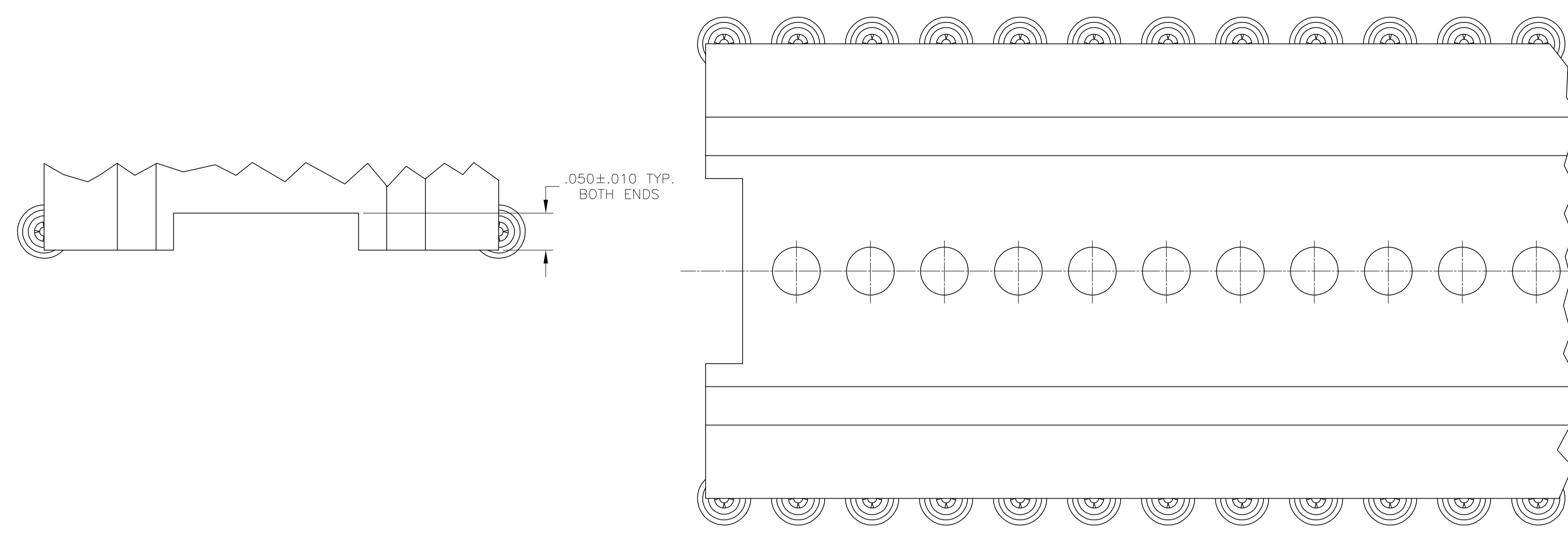

DISPOSABLE CARRIER

STANDARD PC LEAD CONTACT ASSY.

.072 REF.

.053 REF.

.020 ± .003 DIA.

THIS DRAWING IS A CONTROLLED DOCUMENT.		DWG: BSV	D40CT04	Tyco Electronics Corporation	
DIMENSIONS: INCHES		CHK: K. WRIGHT	NAME: K. WRIGHT	Harrisburg, Pa 17105-3808	
TOLERANCES UNLESS OTHERWISE SPECIFIED:		PRODUCT SPEC		CARRIER ASS'Y. LEAD SOCKET	
0 PLC	± .01	APPLICATION SPEC		RESTRICTED TO	
1 PLC	± .01	SIZE: A1		CAGE CODE: 00779	
2 PLC	± .01	DRAWING NO: 1437542		REV: 0	
3 PLC	± .002	WEIGHT: -		SCALE: 10:1	
4 PLC	± .0005	CUSTOMER DRAWING		SHEET 3 OF 3	
ANGLES	± 1/2°			REV: 0	
FINISH	-				