



ANATECH ELECTRONICS INC
RF & Microwave Filters & Products

187 MHz Bandpass Filter

Part Number: AE187B10495



Electrical Specifications

Center Frequency: 187.5 MHz

Bandwidth : 3 MHz

Insertion Loss: <2 dB

Impedance: 50 Ohms

Return Loss : 10 dB

Lower Rejection: < 60 dB at 174.25 MHz

Higher Rejection: >60 dB at 200.75 MHz

Power Handling : 0.25 Watt

Mechanical

Mounting Method: Through Holes

Connector Type: N-Type(Female)

Dimensions: 4.0" X 1.25" x 0.75" in.

Environmental

Operating Temperature: -25°C to +70°C

Storage Temperature: -40°C to +90°C

Shock: 10 G. 11ms

Vibration: 10 G. 5 to 200Hz

Outline Drawing :

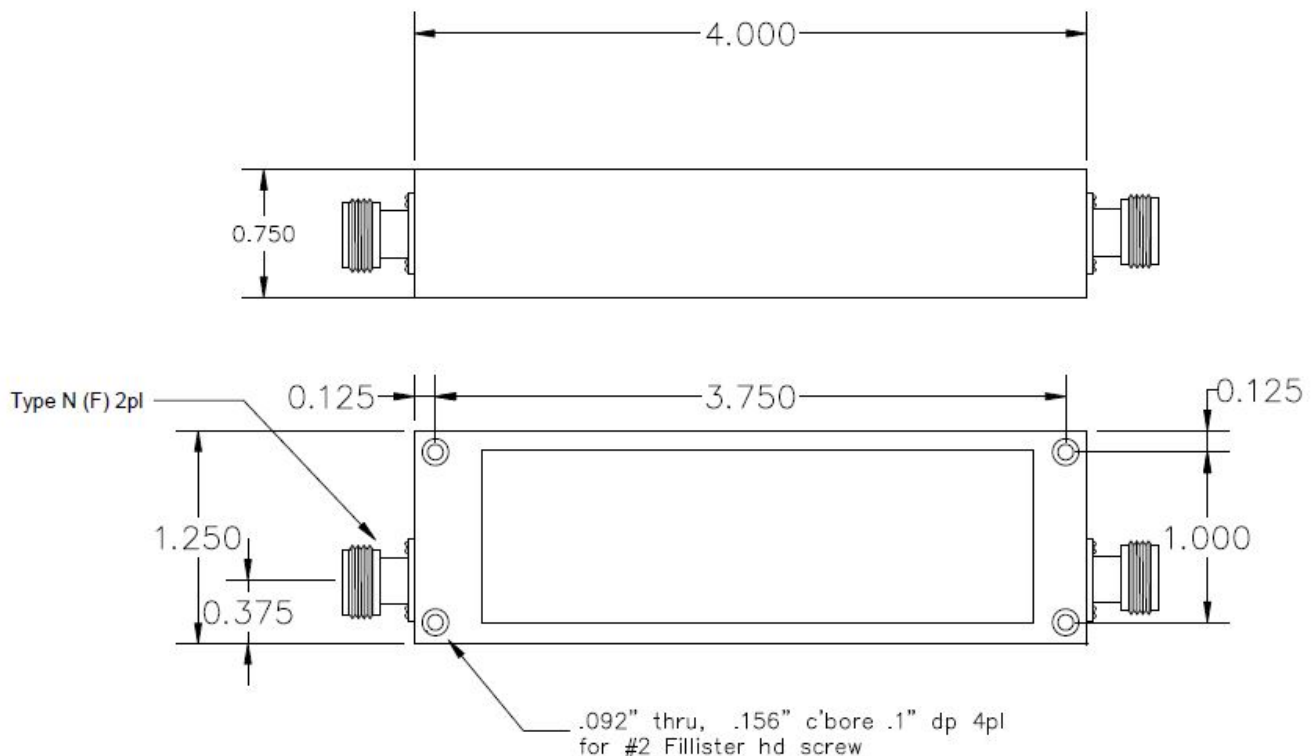



ANATECH ELECTRONICS INC
RF & Microwave Filters & Products

187 MHz Bandpass Filter

Part Number: AE187B10495



Response Plot:

AE187B10495

Lumped Filter S Parameters

