

Board Level Heat Sinks

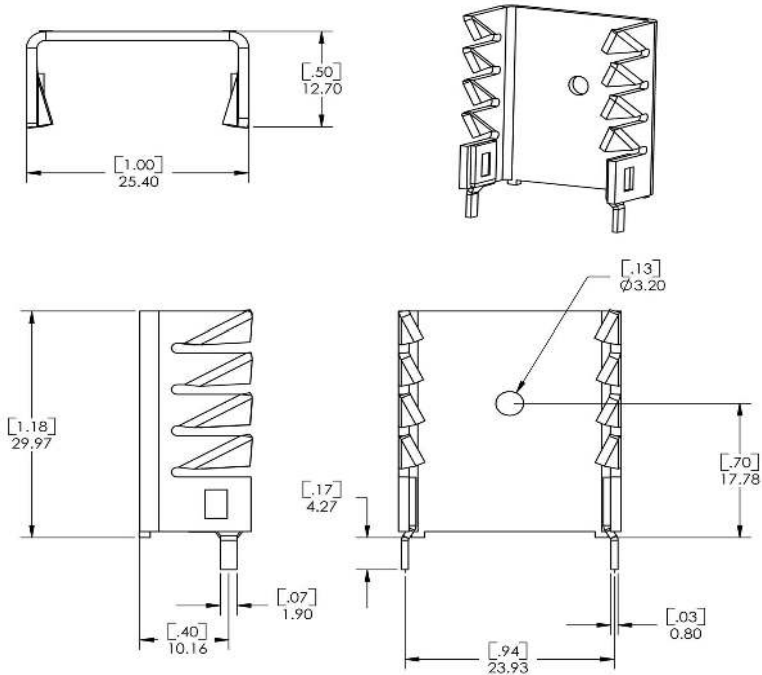

P/N: 825402B03400

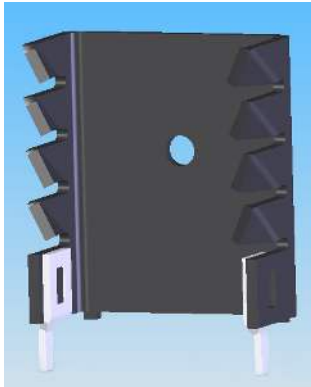

PRODUCT SPECIFICATIONS

- Devices: TO-220
- Size: 25.4 x 12.7 x 30.0 mm
- Material: Aluminum, 1.2 mm Thick
- Type: Stamped
- PCB Mounting: Solderable Tabs
- Finish: Black Anodized
- Package: Bulk
- Accessories: Hardware & Thermal Interface Material

FEATURES & BENEFITS

- Hole for Device Attachment
- Curled Flow Fins
- Vertical Mounting via Solderable Tabs
- RoHS Compliant



CUSTOMIZED HEATSINKS

- Specialized Tabs, Plating
- Specialized Body Configurations
- Contact Applications Engineering

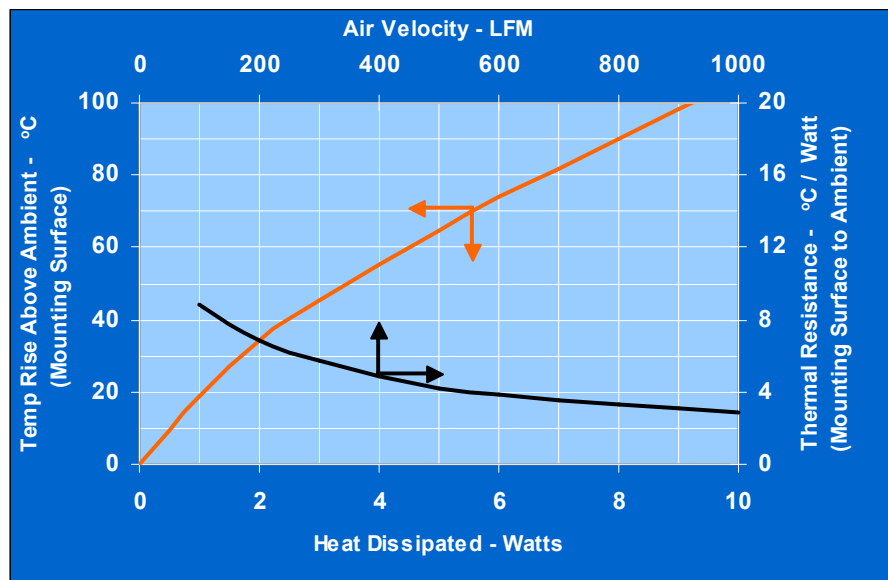

TO-220

COMAIR ROTRON, INC
 8929 Terman Court, San Diego, CA 92121
 Ph (858) 348-6200 Fax (858) 566-4577
 E-mail: sales@comairrotron.com,
 Web: www.comairrotron.com