

**STRAIGHT JACK FULL CRIMP-TYPE  
CABLE 11/50 D**

**R161.243.000**  
**SERIES N**

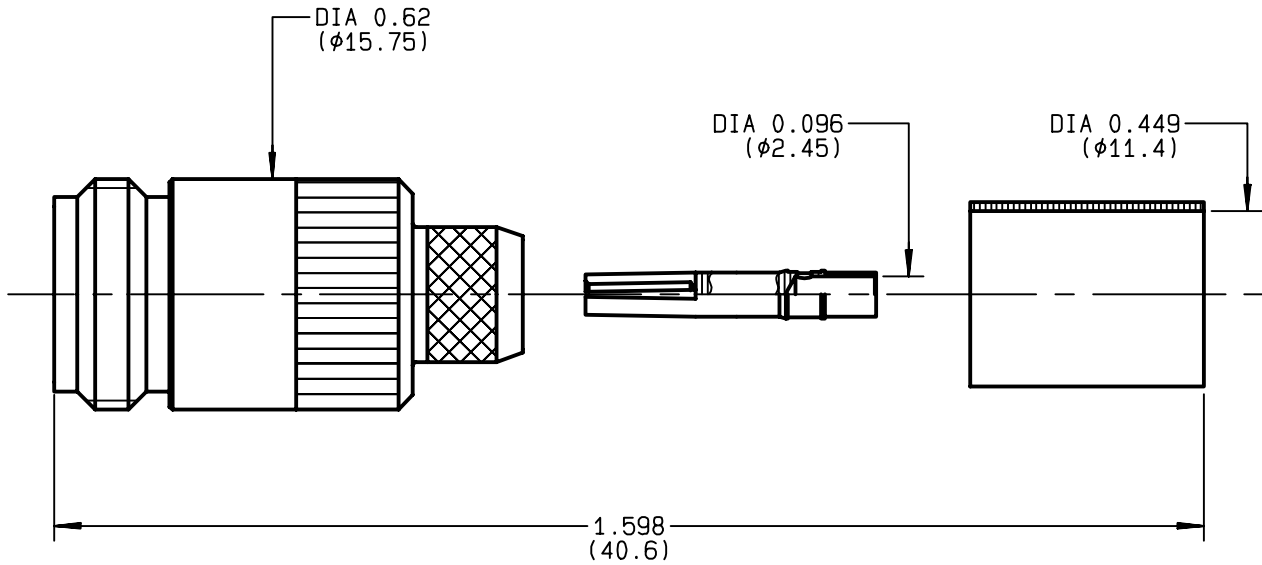

NOMINAL IMPEDANCE	<b>50</b> Ω	CABLES : <b>KX 13</b> <b>RG 214</b> <b>RG 225</b>
FREQUENCY RANGE	<b>0-11</b> GHz	
TEMPERATURE RATING	<b>-55/+155</b> °C	
V.S.W.R	<b>1.30</b> + x F(GHz)Maxi	
RF INSERTION LOSS	<b>0.048</b> √F(GHz) dB Maxi	
VOLTAGE RATING	<b>1400</b> Veff Maxi	
DIELECTRIC WITHSTANDING VOLTAGE	<b>2500</b> Veff Mini	
INSULATION RESISTANCE	<b>5000</b> MΩMini	
HERMETIC SEAL	<b>NA</b> Atm.cm <sup>3</sup> /s	
LEAKAGE (pressurized only)	<b>NA</b>	
MECHANICAL DURABILITY	<b>500</b> Cycles	OTHERS CHARACTERISTICS
WEIGHT	<b>30.8</b> gr	CABLE RETENTION <b>400</b> N Mini
SPECIFICATION		CENTER CONTACT RETENTION
		Axial force - mating end <b>68</b> N Mini
		Axial force - opposite end <b>68</b> N Mini
		Torque <b>NA</b> cm.N Mini
		RECOMMENDED TORQUES
		Mating <b>NA</b> cm.N
		Panel nut <b>NA</b> cm.N
		Clamp nut <b>NA</b> cm.N

CONNECTOR PARTS	MATERIALS	FINISH	(all values are given ) in micrometers
BODY	BRASS	BBR 2	
OUTER CONTACT	BRASS	BBR 2	
CENTER CONTACT	BERYLLIUM COPPER	GOLD 0.5 OVER NICKEL 2	
INSULATOR	PTFE	-	
GASKET		-	
OTHERS PIECES	BRASS	BBR 2	

ISSUE	CREATION DATE	FILE PART-NUMBER
<b>9726M00</b>	<b>21/07/1993</b>	



BONOMINI

The information given here is subject to change without notice.  
Design changes may be in order to improve the product .

*Connect to the future*



**R161.243.000**

ISSUE **9726M00** SERIES **N**

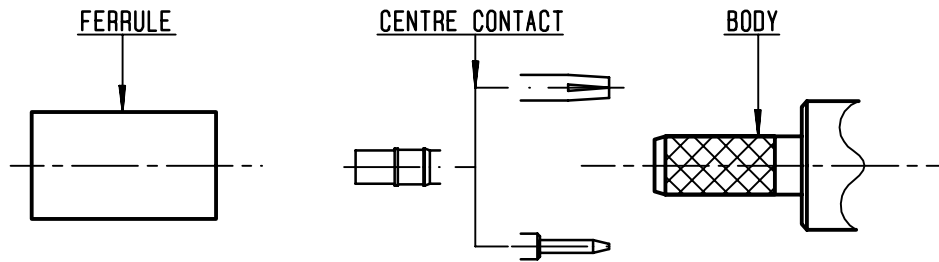

①

Slide onto the cable the ferrule  
Strip the cable .  
-  
-

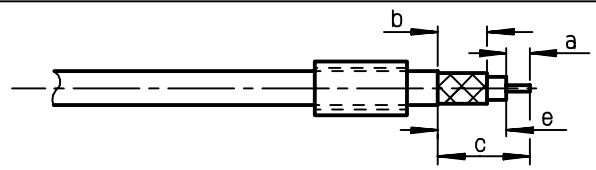

Stripping	a	b	c	d	e
inch	0.197	0.315	0.551	0	0.354
mm	5	8	14		9

②

Slide on centre contact until it bottoms against cable dielectrique .  
Crimp centre contact .  
Crimping tool : R282 231 000 ( Hex. : .100 )  
or R282 293 000 ( M22520/5-01 )  
+ dies R282 235 116 ( Y 116 DANIELS ).  
-  
-

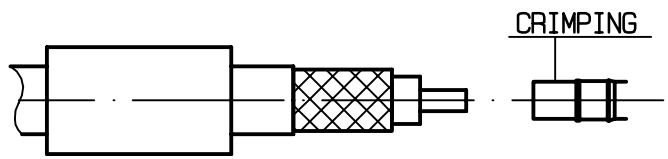

③

Fan the braid .  
Slide cable dielectrique into the body while gently ginding the braid over the knurl  
Push until the dielectrique clicks into position .  
Slide ferrule over braid in direction F .

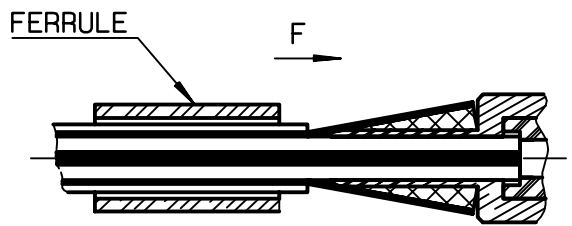

④

Crimp the ferrule with crimping tool R 282 231 000 ( Hex. : .415 ) or crimping tool R282 293 000 ( M22520/5-01 ) + dies R282 235 116 ( Y 116 DANIELS ).  
Cut the excess of braid .  
-  
-

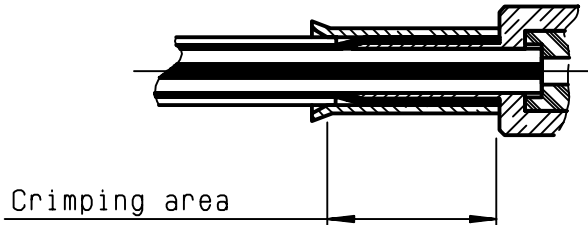

BONOMINI