

Series E photodiodes are Blue-enhanced detectors with high quality color-correcting filters. The resulting spectral response approximates that of the human eye.

In addition to the Series E photodiodes listed, OSI Optoelectronics can provide other photodiodes in this catalog with a variety of optical filters.

### APPLICATIONS

- Photometry/Radiometry
- Medical Instrumentation
- Analytical Chemistry

### FEATURES

- Human Eye Response
- TO Can Packages

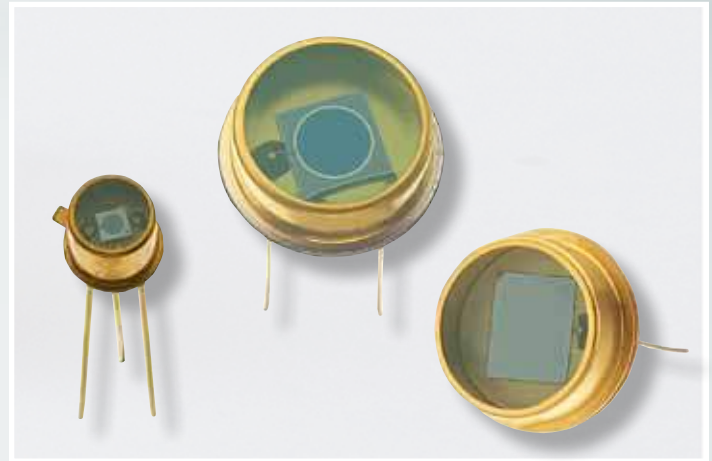

Model Number	Active Area		Responsivity (nA Lux <sup>-1</sup> )		Dark Current (nA)		NEP (WHz <sup>-1/2</sup> )	Capacitance (pF)		Shunt Resistance (MΩ)**		Reverse Voltage (DC)	Spectral Curve	Temp. Range (°C)		Package Style †
	Area (mm <sup>2</sup> )	Dimensions (mm)	min.	typ.	max.	typ.	550 nm VR=0	Vr=0V max.	Vr=12V max.	min.	typ.	max.		Operating	Storage	
<b>OSD-E Series</b>																
OSD1-E	1	1.0 x 1.0	1	2.2	1	0.2	1.5 x 10 <sup>-14</sup>	35	7	250	1000	15	1	-25 ~ +85	-40 ~ +120	7 / TO-18
OSD3-E	3	2.5 x 1.2	3	6.6	2	0.5	1.8 x 10 <sup>-14</sup>	80	20	100	700	15	1	-25 ~ +85	-40 ~ +120	7 / TO-18
OSD5-E	5	2.5 φ	5	11	2	0.5	1.9 x 10 <sup>-14</sup>	130	35	100	600	15	1	-25 ~ +85	-40 ~ +120	5 / TO-5
OSD15-E	15	3.8 x 3.8	15	33	10	2	5.2 x 10 <sup>-14</sup>	390	80	50	80	15	1	-25 ~ +85	-40 ~ +120	5 / TO-5
OSD60-E	100	11.3 φ	30	56	30	8	1.2 x 10 <sup>-13</sup>	2500	520	2	10	15	2	-25 ~ +85	-40 ~ +120	69 / TO-8

Characteristics measured at 22° C (±2) and a reverse bias of 12 volts unless otherwise stated.

\*\* Shunt Resistance measured at +/- 10mV.

† For mechanical drawings please refer to pages 61 thru 73.

### Unit Conversion Table for Illuminance

The Series E photodiodes have been color corrected to provide a photopic eye response. These devices can be used as low illuminance monitors, i.e. visible light measurement instruments and adjusting brightness of visible display.

Lux lx (lm/m <sup>2</sup> )	Phot Ph (lm/cm <sup>2</sup> )	Foot-candle fc (lm/ft <sup>2</sup> )	Watt per square cm* W/cm <sup>2</sup>
1	1.000 x 10 <sup>-4</sup>	9.290 x 10 <sup>-2</sup>	5.0 x 10 <sup>-6</sup>
1.000 x 10 <sup>4</sup>	1	9.290 x 10 <sup>2</sup>	9.290 x 10 <sup>-2</sup>
1.076 x 10 <sup>1</sup>	1.076 x 10 <sup>-3</sup>	1	5.0 x 10 <sup>-5</sup>
2.0 x 10 <sup>5</sup>	1.0 x 10 <sup>1</sup>	1.9 x 10 <sup>4</sup>	1

\*Total irradiance (measured value) by the CIE standard light source "A".

### CIE Curve vs. E Type Parts

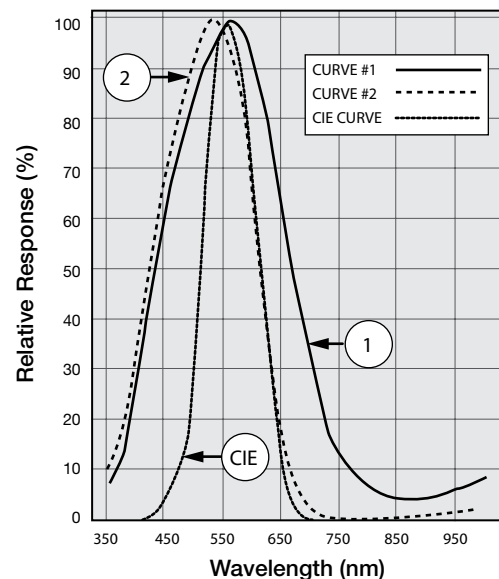

## AVOID DIRECT LIGHT

Since the spectral response of silicon photodiode includes the visible light region, care must be taken to avoid photodiode exposure to high ambient light levels, particularly from tungsten sources or sunlight. During shipment from OSI Optoelectronics, your photodiodes are packaged in opaque, padded containers to avoid ambient light exposure and damage due to shock from dropping or jarring.

## AVOID SHARP PHYSICAL SHOCK

Photodiodes can be rendered inoperable if dropped or sharply jarred. The wire bonds are delicate and can become separated from the photodiode's bonding pads when the detector is dropped or otherwise receives a sharp physical blow.

## CLEAN WINDOWS WITH OPTICAL GRADE CLOTH / TISSUE

Most windows on OSI Optoelectronics photodiodes are either silicon or quartz. They should be cleaned with isopropyl alcohol and a soft (optical grade) pad.

## OBSERVE STORAGE TEMPERATURES AND HUMIDITY LEVELS

Photodiode exposure to extreme high or low storage temperatures can affect the subsequent performance of a silicon photodiode. Storage temperature guidelines are presented in the photodiode performance specifications of this catalog. Please maintain a non-condensing environment for optimum performance and lifetime.

## OBSERVE ELECTROSTATIC DISCHARGE (ESD) PRECAUTIONS

OSI Optoelectronics photodiodes, especially with IC devices (e.g. Photops) are considered ESD sensitive. The photodiodes are shipped in ESD protective packaging. When unpacking and using these products, anti-ESD precautions should be observed.

## DO NOT EXPOSE PHOTODIODES TO HARSH CHEMICALS

Photodiode packages and/or operation may be impaired if exposed to CHLOROTHENE, THINNER, ACETONE, or TRICHLOROETHYLENE.

## INSTALL WITH CARE

Most photodiodes in this catalog are provided with wire or pin leads for installation in circuit boards or sockets. Observe the soldering temperatures and conditions specified below:

Soldering Iron:	Soldering 30 W or less Temperature at tip of iron 300°C or lower.
Dip Soldering:	Bath Temperature: 260±5°C. Immersion Time: within 5 Sec. Soldering Time: within 3 Sec.
Vapor Phase Soldering:	DO NOT USE
Reflow Soldering:	DO NOT USE

Photodiodes in plastic packages should be given special care. Clear plastic packages are more sensitive to environmental stress than those of black plastic. Storing devices in high humidity can present problems when soldering. Since the rapid heating during soldering stresses the wire bonds and can cause wire to bonding pad separation, it is recommended that devices in plastic packages to be baked for 24 hours at 85°C.

The leads on the photodiode **SHOULD NOT BE FORMED**. If your application requires lead spacing modification, please contact OSI Optoelectronics Applications group at (310)978-0516 before forming a product's leads. Product warranties could be voided.



\*Most of our standard catalog products are RoHS Compliant. Please contact us for details

# Mechanical Drawings

Mechanical Specifications and Die Topography

## 1. Parameter Definitions:

A = Distance from top of chip to top of glass.

a = Photodiode Anode.

B = Distance from top of glass to bottom of case.

c = Photodiode Cathode

(Note: cathode is common to case in metal package products unless otherwise noted).

W = Window Diameter.

F.O.V. = Filed of View (see definition below).

## 2. Dimensions are in inches (1 inch = 25.4 mm).

## 3. Pin diameters are $0.018 \pm 0.002$ " unless otherwise specified.

## 4. Tolerances (unless otherwise noted)

General:  $0.XX \pm 0.01$ "

$0.XXX \pm 0.005$ "

Chip Centering:  $\pm 0.010$ "

Dimension 'A':  $\pm 0.015$ "

## 5. Windows

All '**UV**' Enhanced products are provided with QUARTZ glass windows,  $0.027 \pm 0.002$ " thick.

All '**XUV**' products are provided with removable windows.

All '**DLS**' PSD products are provided with A/R coated glass windows.

All '**FIL**' photoconductive and photovoltaic products are epoxy filled instead of glass windows.

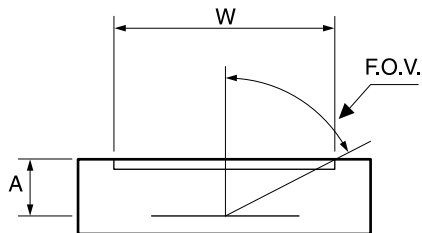

$$F.O.V. = \tan^{-1} \left( \frac{W}{2A} \right)$$

For Further Assistance  
Please Call One of Our Experienced  
Sales and Applications Engineers

**310-978-0516**

**OSI Optoelectronics**  
An OSI Systems Company

- Or -

visit our website at

[www.osioptoelectronics.com](http://www.osioptoelectronics.com)

# Mechanical Specifications

All units in inches. Pinouts are bottom view.

1 TO-18				2 TO-5				3 TO-8																																			
Products:				Products:				Products:																																			
<p>PIN-020A PIN-040A PIN-040-DP/SB</p> <p>2 Case 3c ○ 1a</p> <p>Pin Circle Dia.=0.100</p> <table border="1"> <thead> <tr> <th>P/N</th> <th>A</th> <th>B</th> <th>W</th> </tr> </thead> <tbody> <tr> <td>PIN-020A</td> <td>0.075</td> <td>0.200</td> <td>0.155</td> </tr> <tr> <td>PIN-040A</td> <td>0.075</td> <td>0.200</td> <td>0.155</td> </tr> </tbody> </table>				P/N	A	B	W	PIN-020A	0.075	0.200	0.155	PIN-040A	0.075	0.200	0.155	<p>PIN-5DI PIN-5DPI PIN-13DI PIN-13DPI PIN-5-YAG CD-25T</p> <p>CD-25T 3c ○ 1a 2 a</p> <p>All Others 3c ○ 1a 2 Case</p> <p>Pin Circle Dia.=0.200</p> <table border="1"> <thead> <tr> <th>P/N</th> <th>A</th> <th>B</th> <th>W</th> </tr> </thead> <tbody> <tr> <td>All Others</td> <td>0.094</td> <td>0.180</td> <td>0.240</td> </tr> <tr> <td>CD-25T</td> <td>0.050</td> <td>0.130</td> <td>0.23</td> </tr> </tbody> </table>				P/N	A	B	W	All Others	0.094	0.180	0.240	CD-25T	0.050	0.130	0.23	<p>PIN-6DI PIN-6DPI PIN-44DI PIN-44DPI</p> <p>APD50-8-150-TO8</p> <p>3a ○ 1c 2 Case PIN-6DI, PIN-6DPI APD50-8-150-TO8</p> <p>1a ○ 2c 3 Case PIN-44DI, PIN-44DPI, OSD35-0, OSD35-7Q</p> <table border="1"> <thead> <tr> <th>P/N</th> <th>A</th> </tr> </thead> <tbody> <tr> <td>PIN-6DI/6DPI APD50-8-150-TO8</td> <td>0.115</td> </tr> <tr> <td>PIN-44DI/44DPI</td> <td>0.125</td> </tr> <tr> <td>OSD35-0</td> <td>0.130</td> </tr> </tbody> </table> <p>Pin Circle Dia.=0.295</p>				P/N	A	PIN-6DI/6DPI APD50-8-150-TO8	0.115	PIN-44DI/44DPI	0.125	OSD35-0	0.130
P/N	A	B	W																																								
PIN-020A	0.075	0.200	0.155																																								
PIN-040A	0.075	0.200	0.155																																								
P/N	A	B	W																																								
All Others	0.094	0.180	0.240																																								
CD-25T	0.050	0.130	0.23																																								
P/N	A																																										
PIN-6DI/6DPI APD50-8-150-TO8	0.115																																										
PIN-44DI/44DPI	0.125																																										
OSD35-0	0.130																																										

4 TO-18				5 TO-5				6 TO-8																																				
Products:				Products:				Products:																																				
<p>PIN-2DI PIN-2DPI PIN-3CDI PIN-3CDP PIN-3CDPI</p> <p>3c ○ 1a 2 Case</p> <p>Pin Circle Dia.=0.100</p> <table border="1"> <thead> <tr> <th>A</th> <th>B</th> </tr> </thead> <tbody> <tr> <td>0.070</td> <td>0.200</td> </tr> <tr> <td>0.090</td> <td>0.150</td> </tr> </tbody> </table>				A	B	0.070	0.200	0.090	0.150	<p>PIN-5D PIN-5DP PIN-5DP/SB PIN-13D PIN-13DP PIN-005E-550F</p> <p>UV-001 UV-005 UV-005DQ UV-005EQ UV-013DQ UV-013EQ UV-015</p> <p>OSD-5-0 OSD15-0 OSD5-5T OSD15-5T</p> <p>PIN-5D, PIN-5DP, PIN-5DP/SB, PIN-13D, PIN-13DP, PIN-005E-550F UV-005DQ, UV-005EQ, UV-013DQ, UV-013EQ 15OSD-5-0, OSD15-0, OSD5-5T, OSD15-5T OSD5-8-7Q, OSD5-8-7U</p> <p>3c ○ 1a</p> <p>1c ○ 3a</p> <p>UV-001, UV-005, UV-015</p> <p>Pin Circle Dia.=0.200</p> <table border="1"> <thead> <tr> <th>P/N</th> <th>A</th> <th>B</th> </tr> </thead> <tbody> <tr> <td>OSD-Prefix Devices</td> <td>0.050</td> <td>0.130</td> </tr> <tr> <td>UV-XXXDQ</td> <td>0.065</td> <td>0.138</td> </tr> <tr> <td>UV-XXXEQ</td> <td>0.055</td> <td>0.138</td> </tr> <tr> <td>All Others</td> <td>0.102</td> <td>0.180</td> </tr> </tbody> </table> <p>Quartz Window: OSD5.8-7Q UV Transmissive Window: OSD5.8-7U</p>				P/N	A	B	OSD-Prefix Devices	0.050	0.130	UV-XXXDQ	0.065	0.138	UV-XXXEQ	0.055	0.138	All Others	0.102	0.180	<p>PIN-6D PIN-6DP PIN-44D PIN-44DP UV-020 UV-035DQ UV-035EQ UV-035</p> <p>Dimensions</p> <table border="1"> <thead> <tr> <th>P/N</th> <th>A</th> <th>B</th> </tr> </thead> <tbody> <tr> <td>UV-035DQ</td> <td>0.130</td> <td>0.195</td> </tr> <tr> <td>UV-035EQ</td> <td>0.120</td> <td>0.195</td> </tr> <tr> <td>All Others</td> <td>0.140</td> <td>0.205</td> </tr> </tbody> </table> <p>3a ○ 1c PIN-6D, PIN-6DP, PIN-44D, PIN-44DP UV-020, UV-035DQ, UV-035EQ</p> <p>3c ○ 1a UV-035</p> <p>Pin Circle Dia.=0.295</p>				P/N	A	B	UV-035DQ	0.130	0.195	UV-035EQ	0.120	0.195	All Others	0.140	0.205
A	B																																											
0.070	0.200																																											
0.090	0.150																																											
P/N	A	B																																										
OSD-Prefix Devices	0.050	0.130																																										
UV-XXXDQ	0.065	0.138																																										
UV-XXXEQ	0.055	0.138																																										
All Others	0.102	0.180																																										
P/N	A	B																																										
UV-035DQ	0.130	0.195																																										
UV-035EQ	0.120	0.195																																										
All Others	0.140	0.205																																										

7 TO-18				8 TO-18				9 TO-18															
Products:				Products:				Products:															
<p>PIN-3CD PIN-3CDP BPX-65 OSD1-0 OSD1-5T OSD3-5T OSD1-E OSD3-E</p> <p>3c ○ 1a</p> <p>Pin Circle Dia.=0.100</p> <table border="1"> <thead> <tr> <th>P/N</th> <th>A</th> <th>B</th> </tr> </thead> <tbody> <tr> <td>PIN-3CD / 3CDP</td> <td>0.087</td> <td>0.146</td> </tr> <tr> <td>BPX-65</td> <td>0.075</td> <td>0.200</td> </tr> <tr> <td>OSD-Prefix Devices</td> <td>0.080</td> <td>0.200</td> </tr> </tbody> </table> <p>Quartz Window: OSD1.2-7Q UV Transmissive Window: OSD1.2-7U</p>				P/N	A	B	PIN-3CD / 3CDP	0.087	0.146	BPX-65	0.075	0.200	OSD-Prefix Devices	0.080	0.200	<p>PIN-125DPL</p> <p>3c ○ 1a</p> <p>Pin Circle Dia.=0.100</p>				<p>PIN-HR005 PIN-HR008 PIN-HR020 PIN-HR026 PIN-HR040</p> <p>2c 1a ○ 3 Case</p> <p>Pin Circle Dia.=0.100</p>			
P/N	A	B																					
PIN-3CD / 3CDP	0.087	0.146																					
BPX-65	0.075	0.200																					
OSD-Prefix Devices	0.080	0.200																					

# Mechanical Specifications

All units in inches. Pinouts are bottom view.

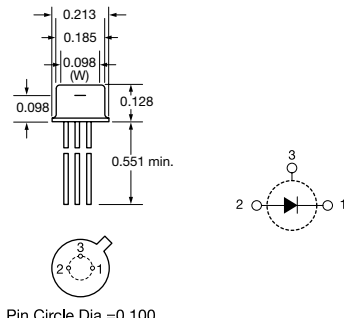
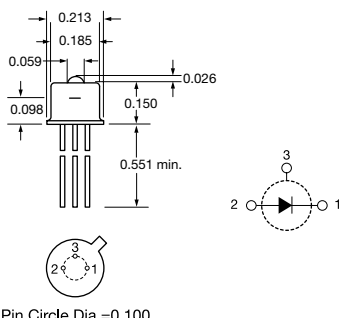
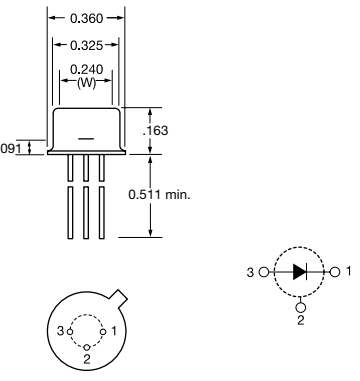
65 TO-52	66 TO-52L	67 TO-5
<p><b>Products:</b> APD02-8-150-T52 APD05-8-150-T52 APD10-8-150-T52</p>  <p>Pin Circle Dia.=0.100</p>	<p><b>Products:</b> APD02-8-150-T52L APD05-8-150-T52L APD10-8-150-T52L</p>  <p>Pin Circle Dia.=0.100</p>	<p><b>Products:</b> APD15-8-150-T05 APD30-8-150-T05</p>  <p>Pin Circle Dia.=0.200</p>

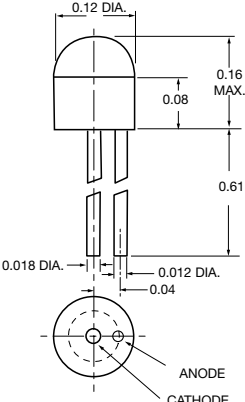
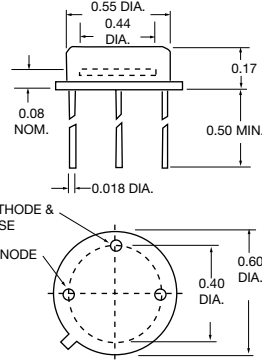
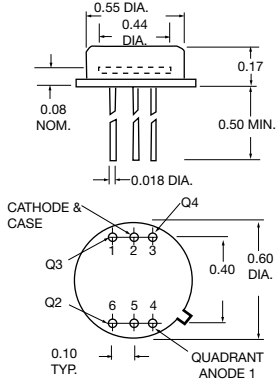
68 Plastic	69 TO-8	70 TO-8
<p><b>Products:</b> CD-1705</p>  <p>ANODE CATHODE</p>	<p><b>Products:</b> OSD60-0 OSD60-ST OSD60-E</p>  <p>CATHODE &amp; CASE ANODE</p>	<p><b>Products:</b> QD50-0</p>  <p>CATHODE &amp; CASE Q4 Q3 Q2 Q1 6 5 4 QUADRANT ANODE 1</p>