

- 1 HOUSING MATERIAL: LIQUID CRYSTAL POLYMER
COLOR: NATURAL.
- 2 CONTACT MATERIAL: PHOSPHOR BRONZE PER UNS ALLOY NO. C51100, TEMPER: H04.
- 3 CONTACT FINISH:(E)
UNDERPLATE (ENTIRE CONTACT):
0.00127 MIN NICKEL PER SAE-AMS-QQ-N-290
ON MATING SURFACES:
FLASH GOLD PER ASTM B 488, OVER
0.00076 MIN PALLADIUM-NICKEL OVER UNDERPLATE, OR
0.00076 MIN GOLD PER ASTM B 488 OVER UNDERPLATE.
ON LEADS:
0.00381 MIN MATTE TIN PER ASTM B 545 OVER UNDERPLATE.
LUBRICATION (MIN MATING SURFACES):
SURFACE CONDITIONER AFTER PLATING.
- 4 PART MARKING LOCATED APPROXIMATELY AS SHOWN.

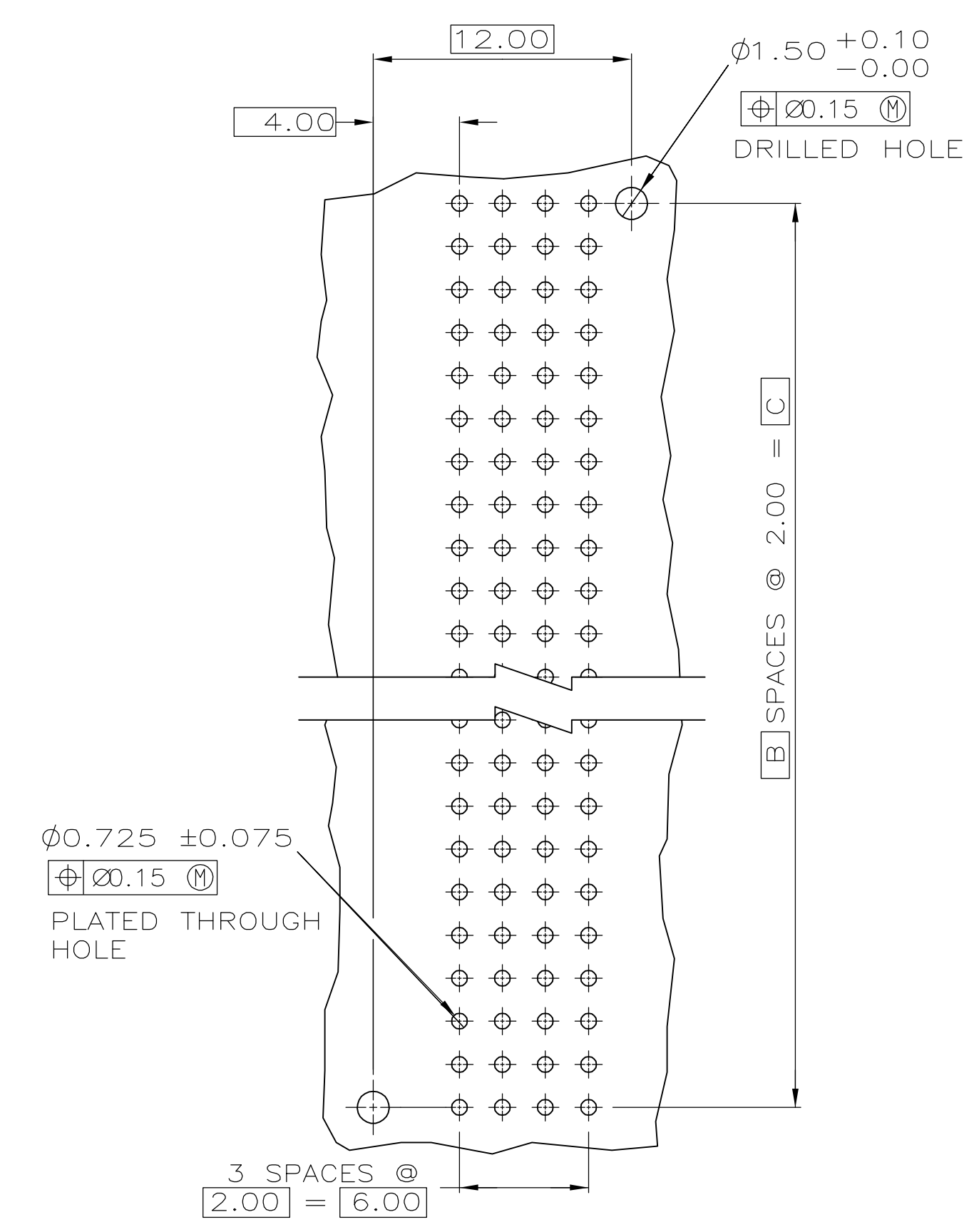

RECOMMENDED CIRCUIT PATTERN
 PER IPC-D300 TYPE II, CLASS C
 (COMPONENT SIDE)

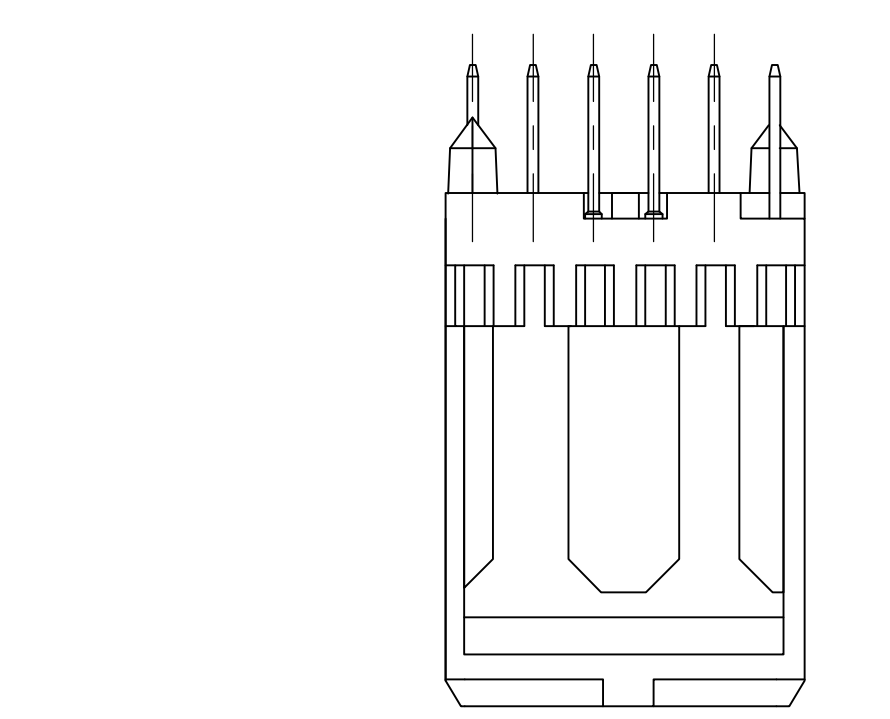
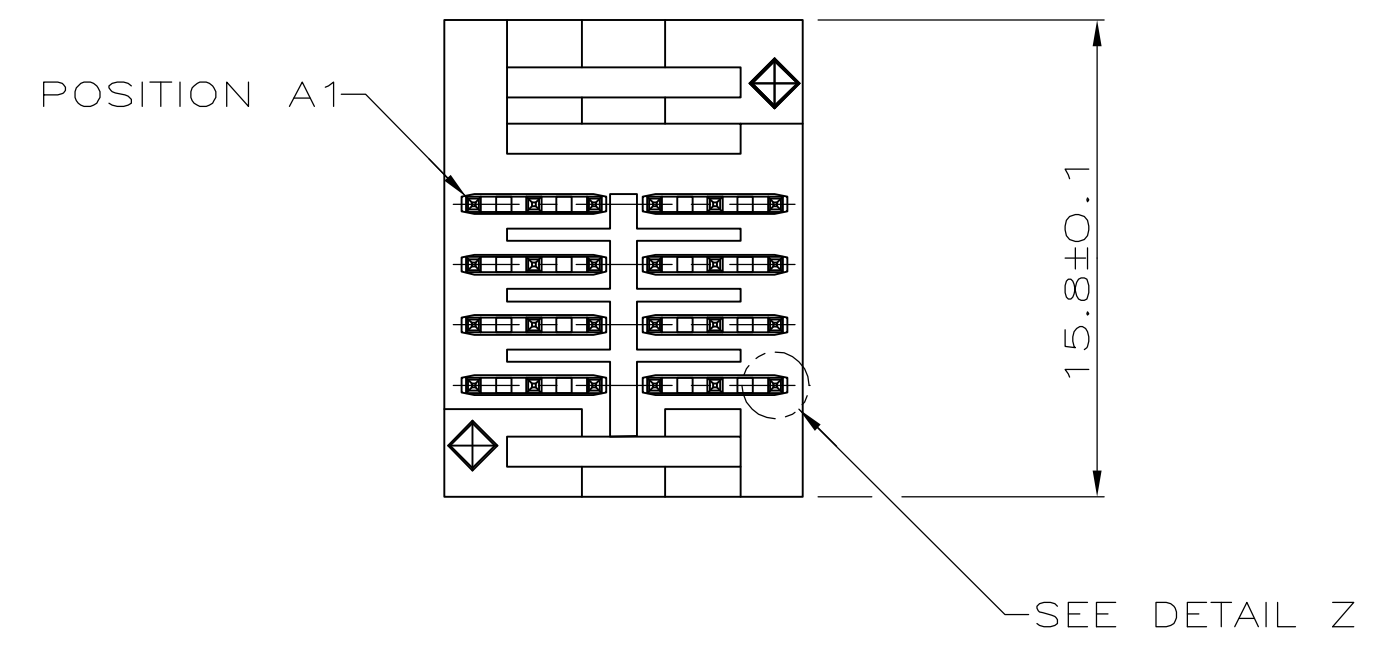
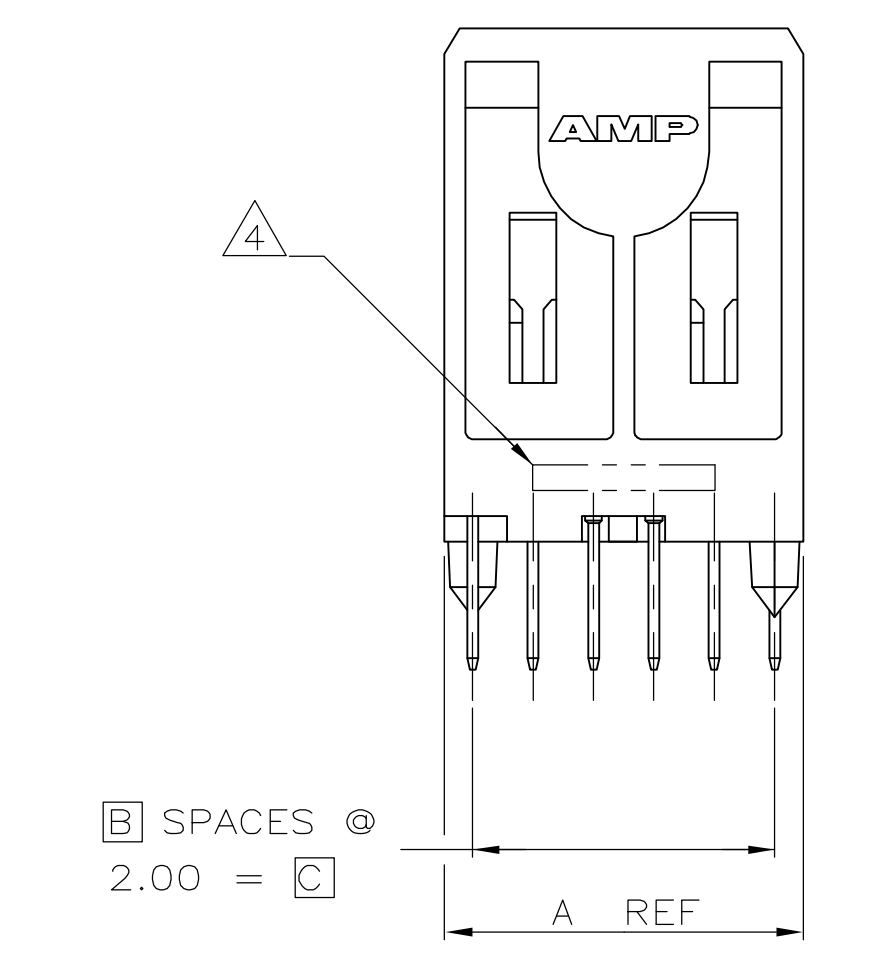
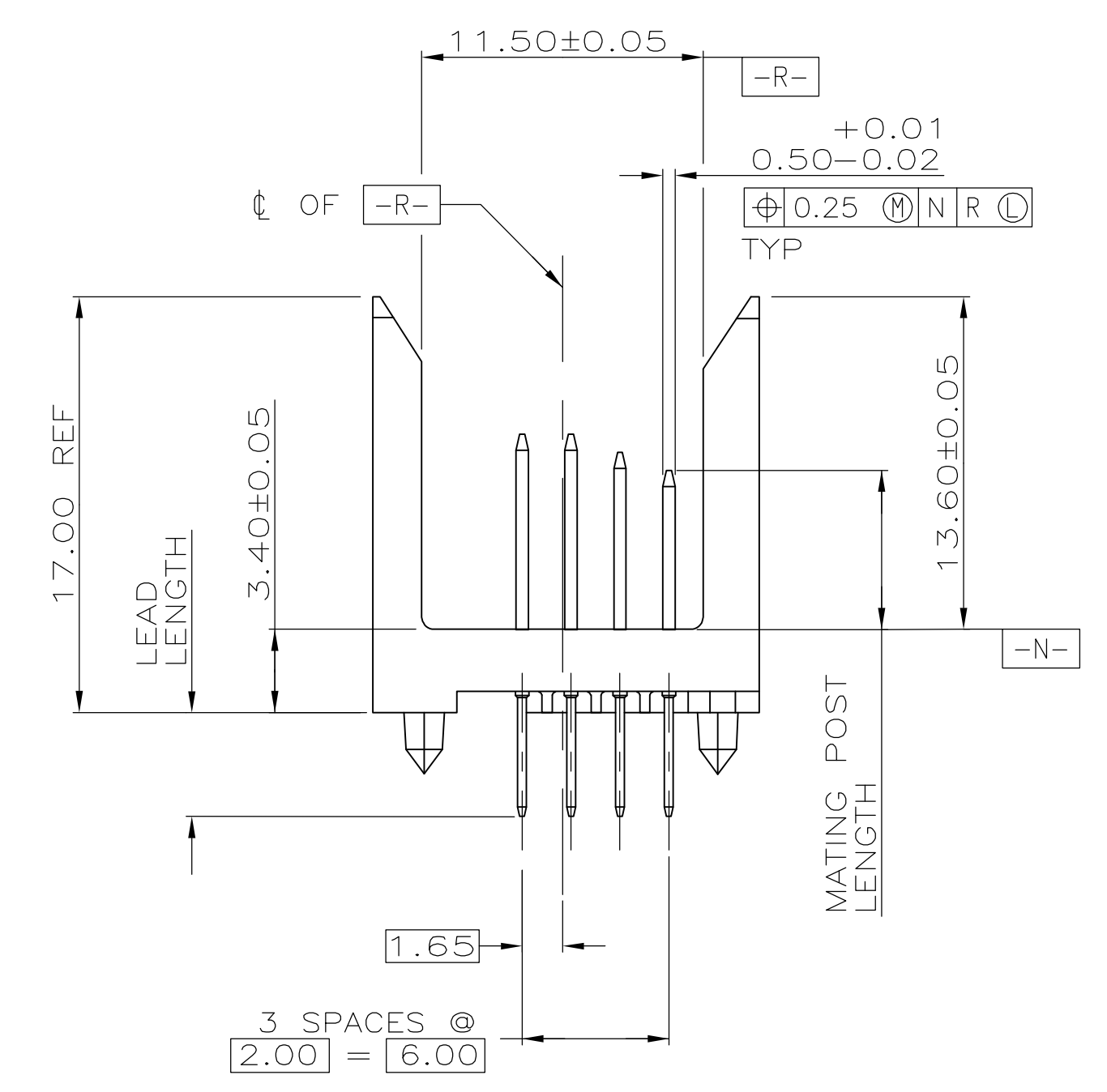
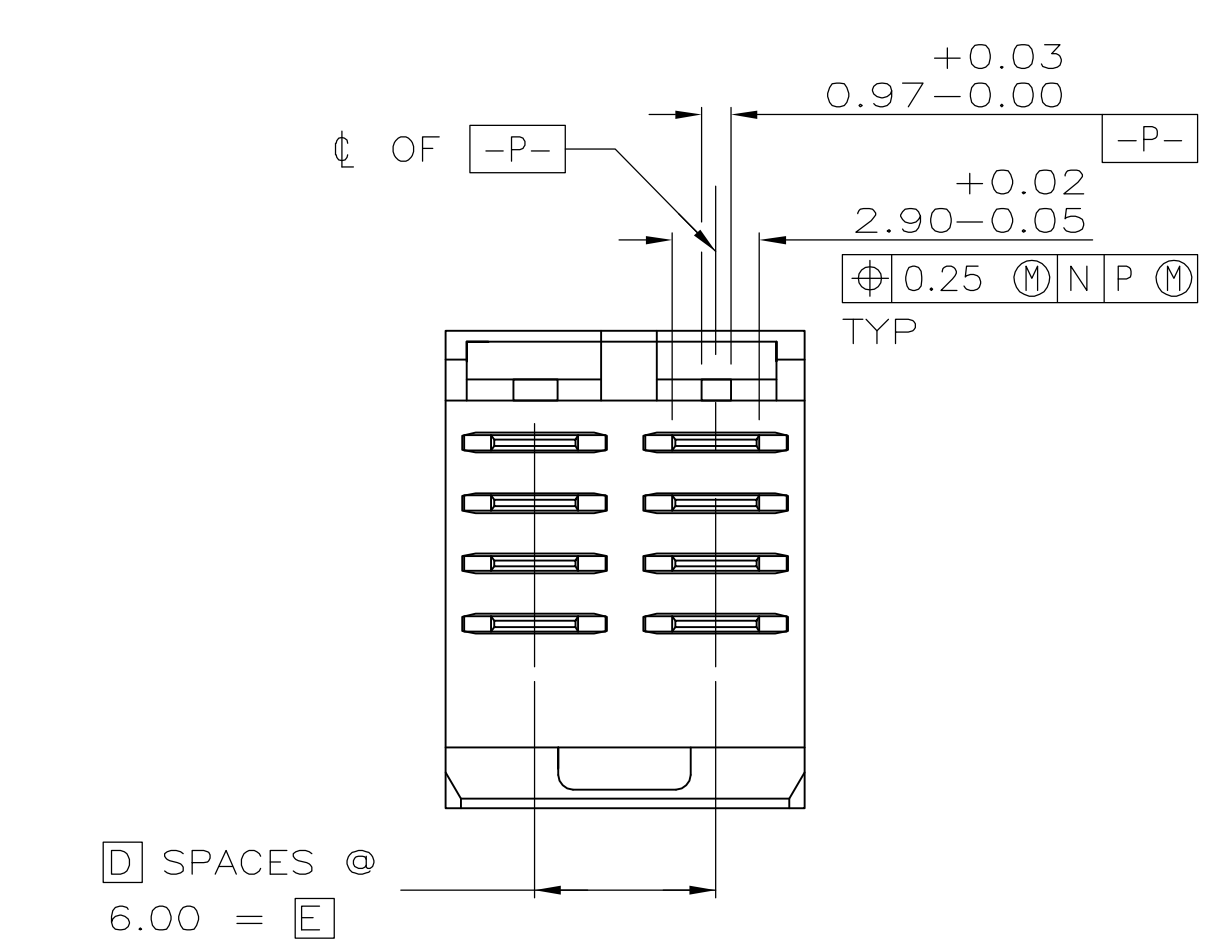
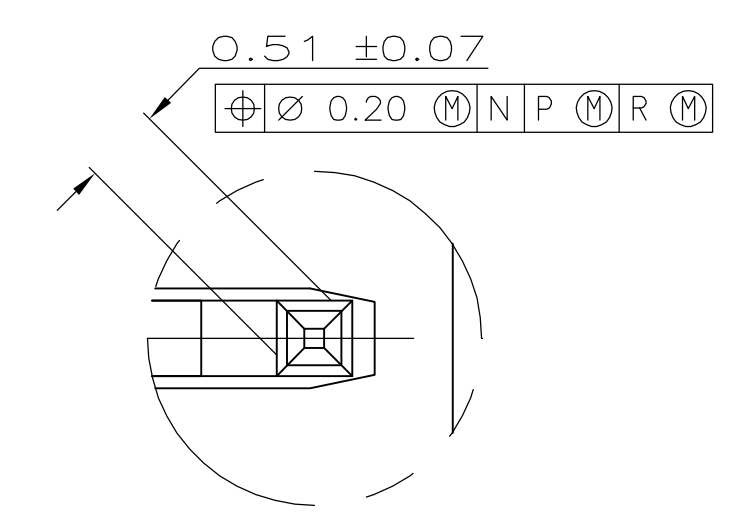

DETAIL Z
 SCALE 20:1

CODE LETTER	MATING POST LENGTH ±0.1	LEAD LENGTH (REF)
CC	8	4.25
CB	7.25	4.25
CA	6.5	4.25

ROW	D	CA	CA			
	C	CB	CB			
	B	CC	CC			
	A	CC	CC			
		1	2	3	4	5
		POWER				
		POSITION				

5536624-1

ROW	D	CC	CC			
	C	CB	CB			
	B	CB	CB			
	A	CA	CA			
		1	2	3	4	5
		POWER				
		POSITION				

5536624-2

6	1	10	5	11.88	3	8	5536624-2
6	1	10	5	11.88	3	8	5536624-1
E	D	C	B	A	FINISH	NO OF POWER POSN	PART NUMBER

THIS DRAWING IS A CONTROLLED DOCUMENT.

DIMENSIONS: mm [INCHES]	TOLERANCES UNLESS OTHERWISE SPECIFIED:	DWN: R. BUCHHEISTER 15/SEP/95	CHK: J. SMALLEY 15/SEP/95	APPRO: D. BAECHTLE 15/SEP/95	NAME: tyco Electronics	Tyco Electronics Corporation Harrisburg, Pa 17105-3608
0 PLC ± -	1 PLC ± -	2 PLC ± 0.15(005)	3 PLC ± -	4 PLC ± -	ANGLES ± -	FINISH
MATERIAL	FINISH	WEIGHT	SIZE: A1	CAGE CODE: 00779	DRAWING NO: 5536624	RESTRICTED TO: -
CUSTOMER DRAWING		SCALE: 4:1	SHEET: 1 OF 1	REV: A		