

LOC	DIST	REVISIONS					
GP	00	P	LTR	DESCRIPTION	DATE	DWN	APVD
		A		RELEASED	27MAR2009	RG	DO
		B		REV. PER ECO-09-019480	25AUG2009	RG	DO

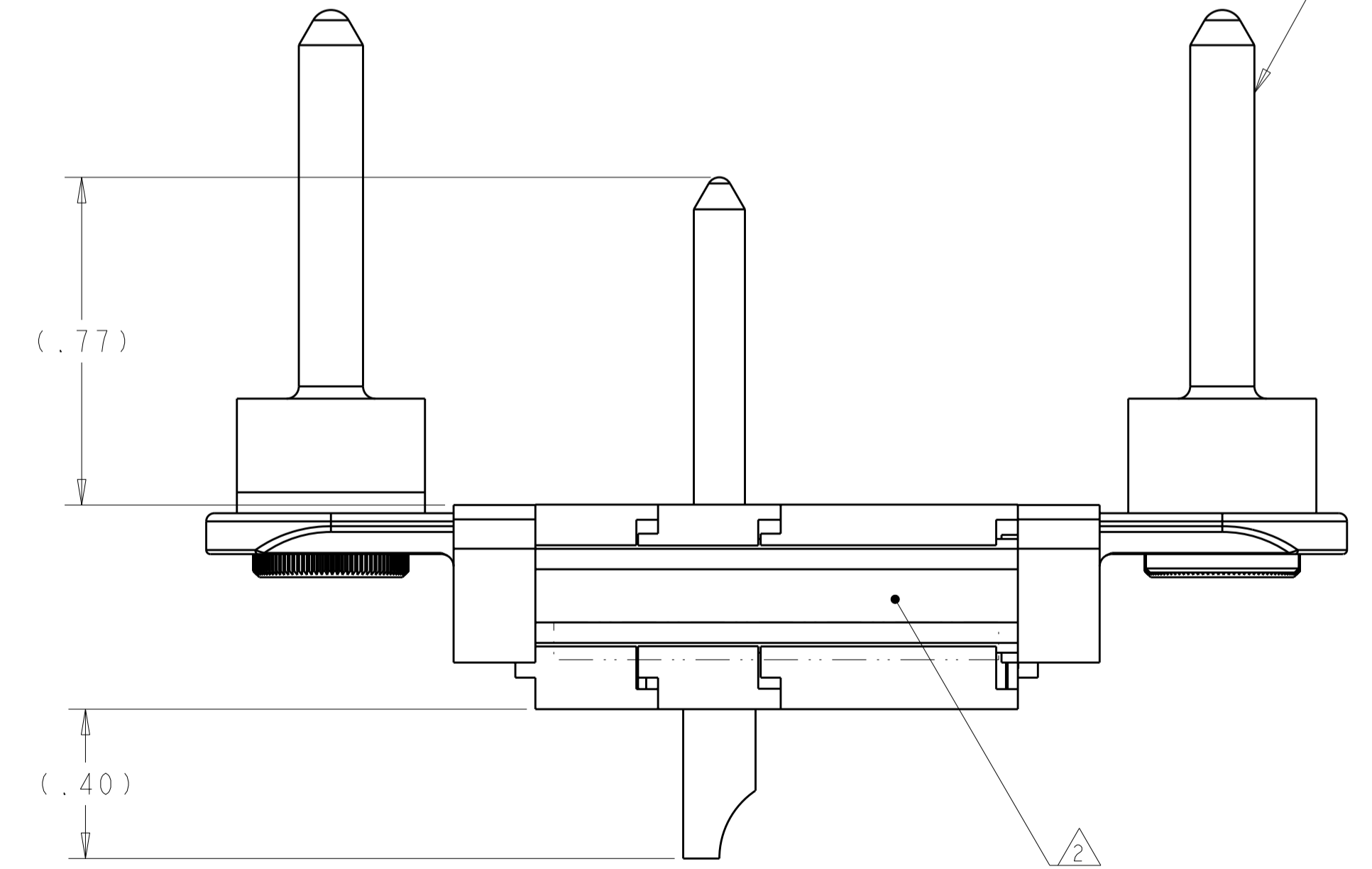
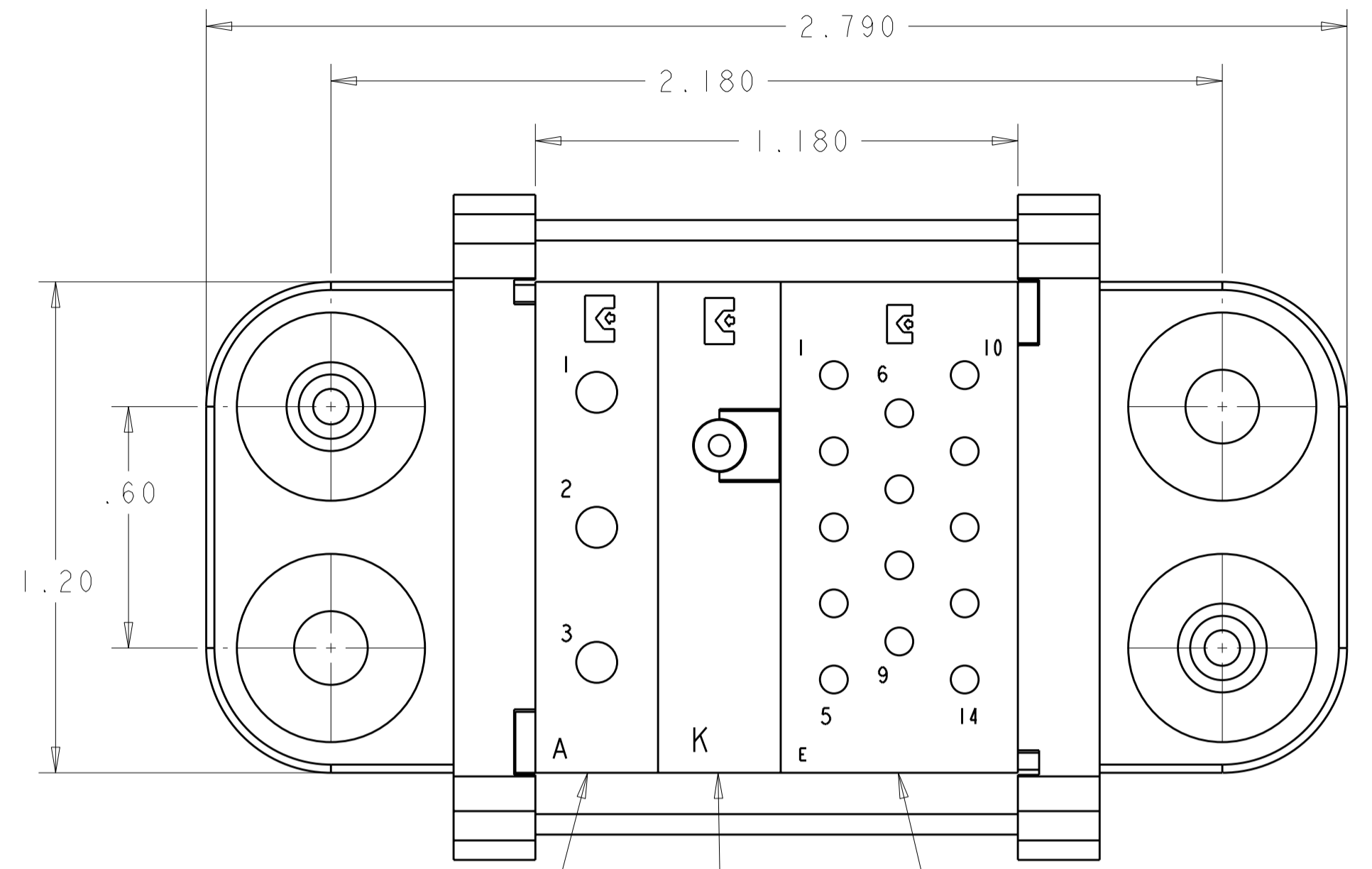

1. PART NUMBER CHANGES AND/OR DESIGN CHANGES AFFECTING ITEM INTERCHANGEABILITY REQUIRE PRIOR TYCO ELECTRONICS APPROVAL AND AUTHORIZATION BY REVISION TO THIS DRAWING.

2. ITEMS PROVIDED TO THIS SPECIFICATION TO BE PERMANENTLY IDENTIFIED PER THE FOLLOWING IDENTIFIER:

YEAR 1 WEEK 1  
 TYCO ELECTRONICS P/N DATE CODE (e.g. 0212)  
 XXXXXXXX-X XXXX

3. MODULES NOTED ARE FOR CRIMP REMOVABLE STYLE CONTACTS. ITEMS E AND F WILL BE PACKAGED AND SHIPPED LOOSE WITH THE CONNECTOR ASSEMBLY.

4. MOUNTING FLANGE BUSHING ACCEPTS 6/32 SCREW (.156 DIA. CLEARANCE HOLE, FLOAT MOUNT) OR 8/32 SCREW (.173 DIA. CLEARANCE HOLE, FIXED MOUNT), USER SUPPLIED.

5. MODULE "K" PIN CONTACT INSTALLED.

14	1766194-1	PIN CONTACTS, CRIMP, SIZE No. 16	F
3	1650153-2	PIN CONTACTS, CRIMP, SIZE No. 12	E
1	1648507-1	MODULE "K"	D
1	1648465-1	MODULE "E"	C
1	1648461-1	MODULE "A"	B
2	6648259-1	END CAP, PANEL MOUNT	A
-1	PART NO.	DESCRIPTION	ITEM NO.

DIMENSIONS: INCHES 		TOLERANCES UNLESS OTHERWISE SPECIFIED: 0 PLC ± 1 PLC ± 2 PLC ±.25 3 PLC ±.010 4 PLC ± ANGLES ± FINISH ±		DWN R.GRZYBOWSKI 17SEP2008 CHK D.ORRIS 17SEP2008 APVD M.PERCHEK 17SEP2008 PRODUCT SPEC APPLICATION SPEC WEIGHT CUSTOMER DRAWING		Tyco Electronics Harrisburg, PA 17105-3608 NAME PIN CONNECTOR ASSEMBLY DOMINO W/PANEL CUT-OUT SIZE CAGE CODE DRAWING NO RESTRICTED TO A200779C-6643969 -	
MATERIAL		WEIGHT		SCALE 3:1		SHEET 1 OF 2 REV B	

**ELCON DOMINO**

4

3

2

1

THIS DRAWING IS UNPUBLISHED. RELEASED FOR PUBLICATION 20  
 © COPYRIGHT 20 BY TYCO ELECTRONICS CORPORATION. ALL RIGHTS RESERVED.

LOC	DIST	REVISIONS			
P	LTR	DESCRIPTION	DATE	DWN	APVD
GP	00	-	SEE SHEET 1	-	-

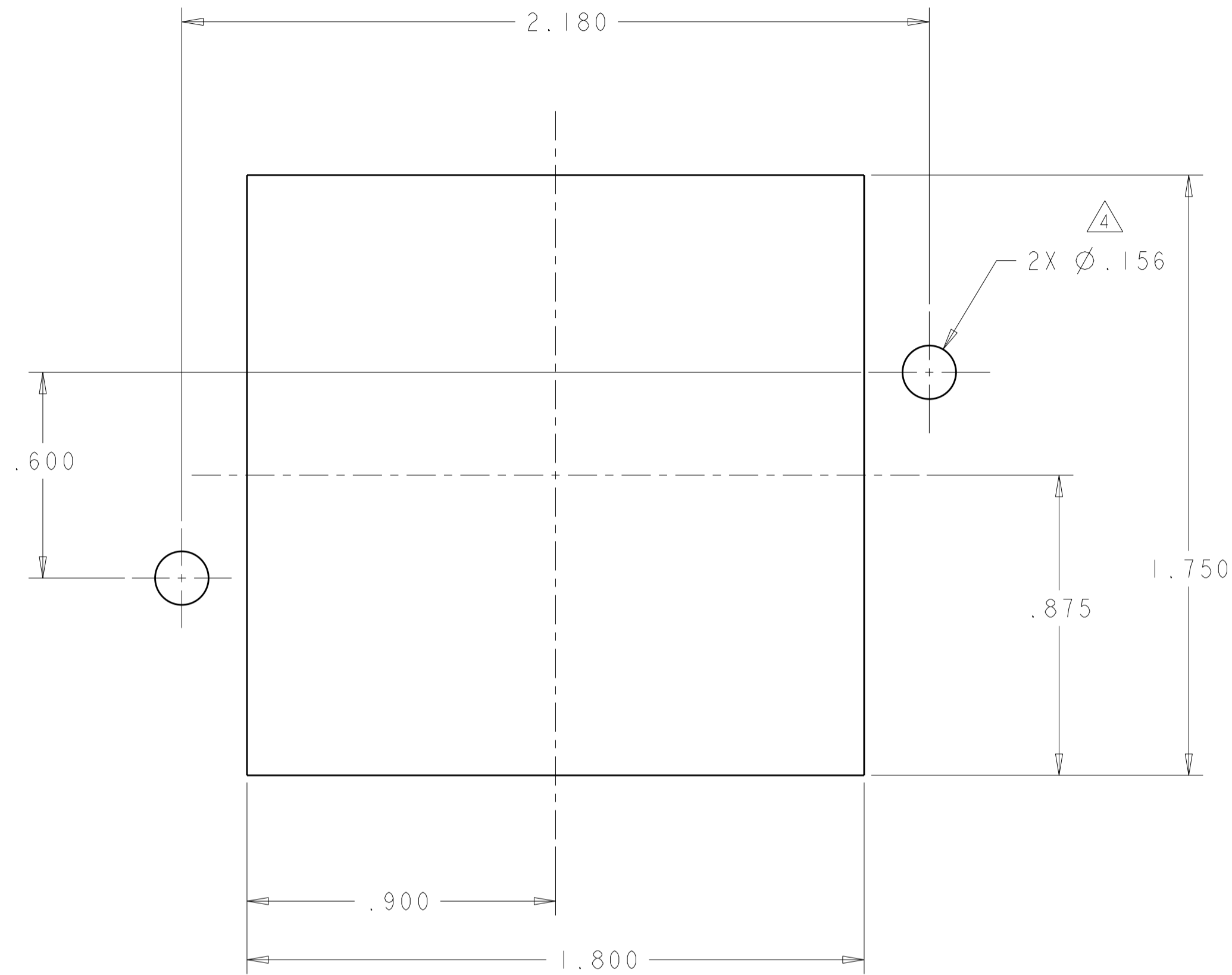

**PIN PANEL MOUNT CUTOUT**  
 COMPONENT SIDE

THIS DRAWING IS A CONTROLLED DOCUMENT FOR TYCO ELECTRONICS CORPORATION. IT IS SUBJECT TO CHANGE AND THE CONTROLLING ENGINEERING ORGANIZATION SHOULD BE CONTACTED FOR THE LATEST REVISION.		DWN R. GRZYBOWSKI 17SEP2008	Tyco Electronics Harrisburg, PA 17105-3608	
DIMENSIONS: INCHES		CHK D. ORRIS 17SEP2008	NAME PIN CONNECTOR ASSEMBLY DOMINO W/PANEL CUT-OUT	
TOLERANCES UNLESS OTHERWISE SPECIFIED: 0 PLC ± 1 PLC ± 2 PLC ±.25 3 PLC ±.010 4 PLC ± ANGLES ± FINISH		APVD M. PERCHERKE 17SEP2008	RESTRICTED TO -	
MATERIAL	-	PRODUCT SPEC -	SIZE A200779	DRAWING NO C-6643969
-		APPLICATION SPEC -	SCALE 3:1	SHEET 2 OF 2 REV B
-		WEIGHT -	CUSTOMER DRAWING	