

APPLICATIONS

LEDRDHB series LED High-bay light collected a thin, smart and stylish shape, better cooling design and high lumen efficacy. We designed multiple mounting constructions for various mounting request. This series has got patent, and UL/cUL, DLC, CE, CB certifications. IP65, suitable for wet locations.



FEATURES

- Housing: ACD12 Aluminum heat sink, SUS back plate, outdoor powder coating
- Optical Lens: High light transmittance PC, anti-UV and fire resistant. Beam angle 90°
- LED: LUMILEDS(LED)150LM/W ; CRI>80.
- DRIVER: 100-277v or 277-480V/50-60Hz, PF≥0.9 ; THD<20%
- Operating Temperature -20° ~ +40°
- Aluminum LED board: High Conductive, waterproof, aging resistance, salt mist resistance, make sure the safety and long lifetime
- The human body induction function (Adapter, sold separately)
- Warranty: 5 years

DIMENSIONS

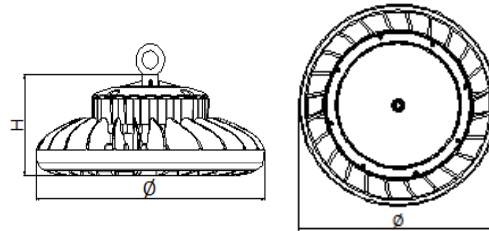

CERTIFICATION



PHOTOMETRY (CLHB-RS-220)

MOUNTING OPTIONS

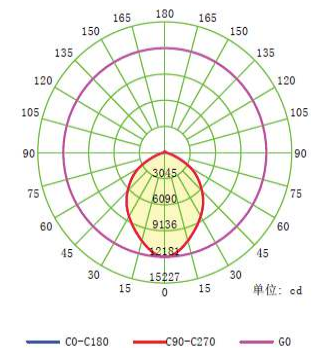
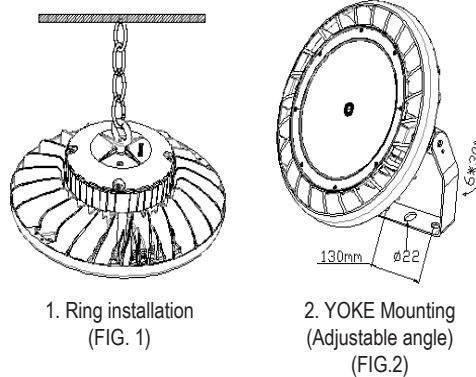

OPTIONAL FEATURES



PRODUCT PARAMETER

MODEL	DIMENSION (W*H)	CERTIFICATE	VOLTAGE	CURRENT	WATT (-8% ~+5%)	LUMENS	LIGHT EFFECT	BEAM ANGLE	FINISH	DIMMING
CLHB-RS100	Φ355*133(mm) Φ14"*5.2"(inch)	UL/cUL/DLC	100-277V	1.1A @100VAC 0.45A @277VAC	100W	12400Lm	120Lm/W	90°	Black White	0-10V /PWM/VR
CLHB-RS150	Φ355*140(mm) Φ14"*5.5"(inch)	UL/cUL/DLC	100-277V	1.7A @100V 0.6A @277VAC	150W	18500Lm	125Lm/W	90°	Black White	0-10V /PWM/VR
CLHB-RSHV-150	Φ355*175(mm) Φ14"*6.9"(inch)	UL/cUL/DLC	277-480V	0.6A @277V 0.35A @480VAC	150W	18500Lm	125Lm/W	90°	Black White	0-10V/PWM/Time Dimmable Type
CLHB-RS220	Φ355*140(mm) Φ14"*5.5"(inch)	UL/cUL/DLC	100-277V	2.4A @100V 0.9A @277VAC	220W	26300Lm	115Lm/W	90°	Black White	0-10V /PWM/VR
CLHB-RSHV-220	Φ355*175(mm) Φ14"*6.9"(inch)	UL/cUL/DLC	277-480V	0.9A @277V 0.52A @480VAC	220W	26300Lm	115Lm/W	90°	Black White	0-10V/PWM/Time Dimmable Type