

NOTES:

1. ALL DIMENSIONS IN MM [INCH]
2. GENERAL TOLERANCE: x.xx ± 0.4
x.xx ± 0.25
3. TERM. NOS. FOR REF. ONLY
4. RATING: 50mA, @12V DC
5. TRAVEL: 0.25±0.1mm
6. CONTACT RESISTANCE: 50m OHMS MAX. INITIAL, .MOS & TTC COMPATIBLE
7. ELECTRICAL LIFE: 5,000,000 CYCLES MIN.
8. INSULTION RESISTANCE: 100M ohms min.
9. DIELECTRIC STRENGTH: 250VA
10. OPERATING TEMP.: -30°C to 85°C
11. ▲DENOTES CRITICAL PARAMETER
- ▲12. CONTACTS: SILVER PLATED
- ▲13. OPENING FORCE: 65±20 GRAMS
14. PACKAGING: TAPE AND REEL, 500 PIECES PER REEL
15. 2002/95/EC (ROHS) COMPLIANT.

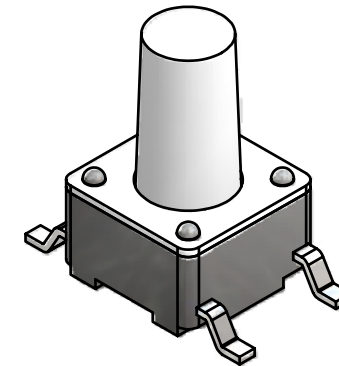

TERMINALS TO BE COPLANAR WITHIN 0.10

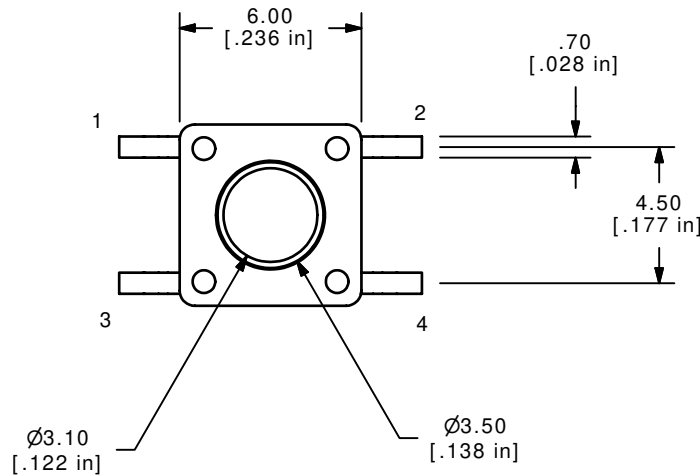
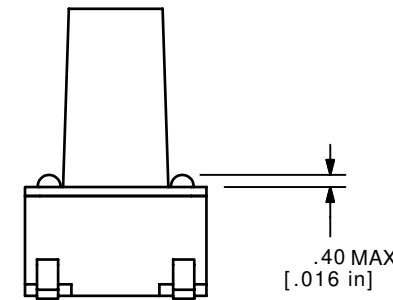
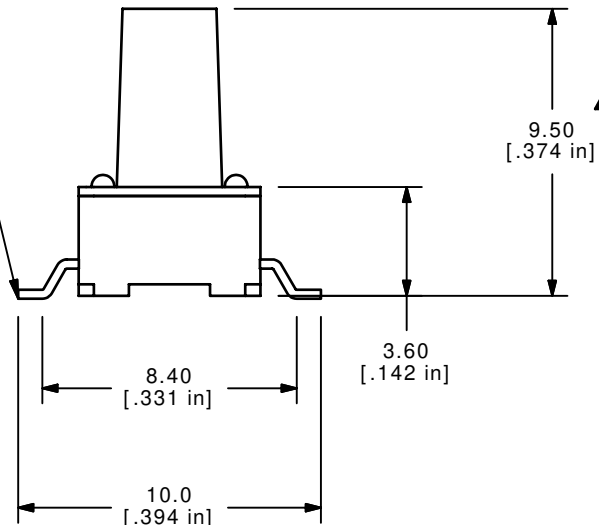

E-SWITCH®

A	16186	new release	7/11/06	rc
REV	PCR NO	DESCRIPTION	DATE	BY

TITLE LL3301BF065QG				
SCALE	DATE	DR	DWG	REV
4	7/11/2006	RC	P090005	A

THE INFORMATION CONTAINED IN THIS DOCUMENT IS PROPRIETARY TO E-SWITCH AND IS NOT TO BE COPIED OR TRANSFERRED